

Nevada Test Site, BREN Tower Complex
(Nevada National Security Site)
Jackass Flats, Area 25
Mercury Vicinity
Nye County
Nevada

HAER NV-47

PHOTOGRAPHS

WRITTEN HISTORICAL AND DESCRIPTIVE DATA

FIELD RECORDS

Historic American Engineering Record
National Park Service
Pacific West Regional Office
333 Bush Street
San Francisco, CA 94104

**HISTORIC AMERICAN ENGINEERING RECORD
NEVADA NATIONAL SECURITY SITE, BREN TOWER COMPLEX**

HAER NO. NV-47

Location: Jackass Flats, Area 25, Nevada National Security Site, Mercury Vicinity, Nye County, Nevada (Field Records, Map 1)
USGS Skull Mountain, Nev., (1983) 7.5' Quadrangle (NAD 27)
UTM Coordinates (NAD 27) for BREN Tower Complex Perimeter (Field Records, Map 2)
Zone 11 Easting 568507 Northing 4072296
Zone 11 Easting 568665 Northing 4071905
Zone 11 Easting 567923 Northing 4070833
Zone 11 Easting 567969 Northing 4070522
Zone 11 Easting 567334 Northing 4070314
Zone 11 Easting 567011 Northing 4070980
Zone 11 Easting 567354 Northing 4071628
Zone 11 Easting 567514 Northing 4071635
Zone 11 Easting 567661 Northing 4071456
Zone 11 Easting 568969 Northing 4071481
Zone 11 Easting 568440 Northing 4072009
Zone 11 Easting 568429 Northing 4072279

Present Owner: U.S. Department of Energy, National Nuclear Security Administration, Nevada Field Office
P.O. Box 98518,
Las Vegas, NV 89193-8518

Present Occupant: Not occupied

Present Use: Vacant; no public access;
Bren Tower and selected outbuildings/structures to be demolished

Significance: The BREN (Bare Reactor Experiment, Nevada) Tower Complex is significant for its role in the history of nuclear testing, radiation dosimetry studies, and early field testing of the Strategic Missile Defense System designs. At the time it was built in 1962, the 1,527 ft (465 m) BREN Tower was the tallest structure west of the Mississippi River and exceeded the height of the Empire State Building by 55 ft (17 m). It remains the tallest ever erected specifically for scientific purposes and was designed and built to facilitate the experimental dosimetry studies necessary for the development of accurate radiation dose rates for the survivors of Hiroshima and Nagasaki. The tower was a key component of the Atomic Bomb Casualty Commission's (ABCC) mission to predict

the health effects of radiation exposure. Moved to its current location in 1966, the crucial dosimetry studies continued with Operation HENRE (High Energy Neutron Reactions Experiment). These experiments and the data they generated became the basis for a dosimetry system called the Tentative 1965 Dose or more commonly the T65D model. Used to estimate radiation doses received by individuals, the T65D model was applied until the mid-1980s when it was replaced by a new dosimetry system known as DS86 based on the Monte Carlo method of dose rate calculation. However, the BREN Tower data are still used for verification of the validity of the DS86 model.

In addition to its importance in radiation health effects research, the BREN Tower Complex is also significant for its role in the Brilliant Pebbles research project, a major component of the Strategic Defense Initiative popularly known as the “Star Wars” Initiative. Instigated under the Reagan Administration, the program’s purpose was to develop a system to shield the United States and allies from a ballistic missile attack. The centerpiece of the Strategic Defense System was space-based, kinetic-kill vehicles. In 1991, BREN Tower was used for the tether tests of the Brilliant Pebbles prototype vehicle at the earth’s surface prior to the more costly space testing program. The success of these tests established the Brilliant Pebbles program as an essential component of America’s space-based missile defense system even after the dismantling of the Soviet Union. Data from the Brilliant Pebbles research program continues to inspire current missile defense system research (Independent Working Group 2009)

Report Prepared by: Susan R. Edwards
Associate Research Archaeologist/Historian
Desert Research Institute
755C East Flamingo Road
Las Vegas, NV 89119-7363

Nancy Goldenberg
Principal Architectural Historian
Carey & Company, Inc.
Old Engine Co., No. 2
460 Bush Street
San Francisco, CA 94108

Date: August 2013

PART I. HISTORICAL INFORMATION

A. Physical History

- 1. Date of Construction:** 1962 and 1965/66
- 2. Architect/Engineer:** Edgerton, Germeshausen & Grier, Inc., Las Vegas, Nevada
Holmes & Narver, Inc., Las Vegas, Nevada
- 3. Original and subsequent owners and occupants:**
1962 U.S. Atomic Energy Commission
1975 Energy Research and Development
1977 U.S. Department of Energy
- 4. Builder/Contractor:** Dresser-Ideco Company, Inc., Arcadia, California and
Columbus, Ohio
- 5. Original plans and construction:** Several hundred microfiche images of the original architectural and structural plans for the BREN Tower and many of the associated outbuildings, structures, and instrument stations are archived at the U.S. Department of Energy's Engineering Nevada National Security Site, Mercury, NV. Digital reproductions of selected engineering drawings are included in the supplemental drawings at the end of this report.
- 6. Alterations and additions:**
1965/66 The BREN Tower was moved from its original location in Area 4 of the Nevada National Security Site (formerly known as the Nevada Test Site) and relocated to its current site in Area 25 in Jackass Flat.

1970 Instrumentation for a series of sonic boom experiments was temporarily attached to the tower and temporary ground-based instrument stations were set up in the surrounding area.

1991 A pair of portable towers and several instrument stands were erected next to the north side of the tower along with a poured concrete pad for the "Brilliant Pebbles" experimental program.

n.d. Several structures/outbuildings erected for Operation HENRE have been removed, but the date of their dismantling is unknown.

n.d. Other concrete pads and instrument stands are located around the base of the tower but cannot be associated with a specific experimental program or project.

B. Contextual Information

The establishment of the continental nuclear proving ground was prompted by the United States' need for greater security and control in its development of a nuclear arsenal during the Cold War. The U.S. nuclear weapons research and development program accelerated after 1949 in response to changing international conditions. First, the former Soviet Union detonated a nuclear device well ahead of American expectations in 1949 (Maag et al. 1982:18; Rhodes 1986:767-769). The outbreak of hostilities on the Korean peninsula in 1950 added to the political uncertainty. The Atomic Energy Commission (AEC) felt the Pacific Proving Ground was no longer secure fearing that the Korean conflict might spread into the region and began searching for a continental test site (Fehner and Gosling 2002:43; Maag et al. 1982:19; Titus 1986). The Nevada Proving Grounds was created by withdrawing lands from the U.S. Air Force controlled Las Vegas-Tonopah Bombing and Gunnery Range in December 1950. Renamed the Nevada Test Site (NTS) in 1955 the facility served as America's main nuclear test site for more than 50 years. In August 2010, the NTS was renamed the Nevada National Security Site (NNSS) to better reflect its current mission that has expanded beyond nuclear deterrence and surveillance to include energy and environmental security efforts. However, in keeping with the historic context of the BREN Tower Complex and the period of its active use, the old NTS designation will be utilized for the following discussion in the interest of clarity and historical accuracy.

Nuclear testing has been depicted as a major and important theme in the history of Nevada (Tlachac 1991a, 1991b). The nuclear research and testing programs carried out at the NTS were fundamental to weapons development, radiation fallout studies, and radiation exposure experiments (Titus 1986). Facilities and sites such as the town of Mercury, Camp Desert Rock, the Environmental Protection Agency's Experimental Farm, the Nuclear Rocket Development Station, Doom Town, Japanese Village, Area 12 Support Facility, the Control Point, and Area 5 atmospheric testing structures provide examples of a wide variety of the early research efforts (Tlachac 1991b). Nuclear testing played a vital role in the national defense of the United States during the Cold War. It was at the NTS where most of the developments and experiments in nuclear weapons were actually tested, both above and below ground.

In addition to weapons testing, research programs at the NTS focused on understanding the effects of nuclear energy on humans and their environment, and more specifically the effects of a nuclear detonation on human populations. One of the earliest studies of this type was Project Ichiban which concentrated on developing a method of evaluating radiation doses received by survivors of Hiroshima and Nagasaki. With the establishment of the Atomic Bomb Casualty Commission (ABCC) in 1947, a comprehensive program was developed to document and analyze the effects of nuclear weapons radiation on survivors and their offspring (Auxier 1964). The success of the initial 1956-1958 series of radiation effects experiments conducted during atmospheric tests at the NTS led to a desire for more extensive dosimetry research. However, a temporary moratorium on nuclear testing (1958-1961) and the eventual ban on atmospheric testing required a different approach to

subsequent dosimetry research. Operations BREN and HENRE utilized nuclear reactors or accelerators instead of atmospheric tests for their experimental protocols. Positioning these radioactive sources on a high tower allowed scientists to simulate the air-burst detonation of a nuclear weapon and obtain data critical to dosimetry research and the long-term medical effects of radiation (REECo 1966b). Operation BREN was conducted in 1962 in Yucca Flat in NTS Area 4. Operation HENRE, however, took place in Jackass Flat in Area 25 after the BREN Tower was dismantled and reassembled in an area farther away from the shock waves generated from underground testing. The HENRE experimental programs were conducted between 1966 and 1969.

The research design for the historical evaluation of the BREN Tower Complex consisted of two parts (see Edwards and Goldenberg 2007). The first focused on reviewing documentation concerning BREN Tower in order to characterize it in both setting and detail and to develop a historical context for its role in the nuclear testing program at the NTS. Documents and historic photographs were obtained from the NNSA/NSO Nuclear Testing Archive in Las Vegas, the NNSA/NSO Technical Library in North Las Vegas, the NNSA/NSO Remote Sensing Laboratory in Las Vegas, and the Defense Threat Reduction Information Analysis Center in Albuquerque, New Mexico. A listing and select examples of engineering drawings of the BREN Tower Complex were obtained from the Archives and Records Center (ARC) in Mercury, Nevada. Also, interviews with John Auxier and Fred Haywood were videotaped to obtain historical background information on the tower and the Operation BREN and HENRE experiment programs. Dr. Auxier and Mr. Haywood were health physicists with Oak Ridge National Laboratories (ORNL) and served key roles in both of these programs. Dr. Auxier was the Technical Director for Operation BREN and the Program Director for the Operation HENRE, Program 1 experiments. Mr. Haywood was the Technical Director for Operation HENRE and the Radiological Safety Officer for Operation BREN. The second part of the evaluation involved an on-site inspection of the complex, detailed descriptions of structures and features, an evaluation of the tower and the analog Japanese House by an architectural historian, and black and white and color photography of the entire BREN Tower Complex.

PART II. ARCHITECTURAL AND ENGINEERING INFORMATION

BREN TOWER COMPLEX

Holmes & Narver, Inc (H&N). and Edgerton, Germeshausen & Grier, Inc. (EG&G), both of Las Vegas, Nevada provided the engineering designs, specifications and drawings for all of the structures and buildings for the original Operation BREN and subsequent Operation HENRE experimental programs. Both H&N and EG&G played prominent roles in developing the NTS infrastructure providing technical services, construction support, and facilities management as well as at other locations within the U.S. nuclear weapons research, development, testing, and production system (i.e., Pacific Proving Grounds, Hanford, etc.). H&N operated on the NTS from 1956 until 1990, while EG&G supported the NTS research efforts from 1951 to 1995 (Brookings Institute 2011; Schwartz 1998).

The BREN Tower itself was constructed by the Dresser-IDECO Company's division that specialized in erecting radio and television towers. The remainder of the BREN complex facilities were built by a combination of H&N, EG&G, and the Reynolds Electrical and Engineering Company, Inc. (REECO), another contractor that provided facilities management and technical services for the NTS from 1953 until the mid 1990s (Brookings Institute 2011; Schwartz 1998).

BREN Tower originally stood in Area 4 in Yucca Flat. At that location, associated structures included a small grouping of light frame Japanese-style houses standing a short distance away. These buildings, known as the Japanese Village, were erected specifically for the 1962 Operation BREN dosimetry studies. Prior to the start of the follow-on Operation HENRE experiments, the tower was moved to its present location in Jackass Flats in NTS Area 25 in the spring of 1966 (Field Records, Photos 1 and 2). A variety of facilities including a Japanese-style house, were erected at the new location to support the Operation HENRE (1966-1969) research studies and later testing programs (1970 through the mid-1990s) (Field Records, Maps 3, 4, 5 and 6). Two buildings, 24 structures and 11 features associated with the experimental programs were identified (Field Records, Map 3) during the 2004/2006 historical evaluation in Area 25 (Edwards and Goldenberg 2007).

General Site Area

Initial construction to support the HENRE reactor experiments in Area 25 included road building, site grading and revetment excavation (Field Records, Maps 4 and 5). The primary road is paved and approaches the BREN Tower from the northeast. Approximately 1.2 mi (1,950 m) long, this road links the tower with Cane Spring Road. A locked gate restricts entry without authorization. A secondary unpaved access road extends northwest from the tower for approximately 0.87 mi (1,400 m). Requiring a high clearance vehicle, it too joins with Cane Spring Road but has no barricade. There is a third road that runs east-west between the paved road and the central runway (see below) (Field Records, Maps 4 and 5).

Three separate 200 ft (61 m) wide smoothed and stabilized bladed areas or “runways” as they were known, radiate outward from BREN Tower. The majority of the experiments requiring significant support structures were erected within the bladed runway areas. The westernmost runway is on the N 55°W line and extends for approximately 2,000 ft (610 m). The central runway is on the N 10°W line and lies just east of the secondary access road. It extends 3,500 ft (1,067 m). The longest runway at 5,280 ft (1,600 m) is on the N 35°E line and parallels the paved access road (Field Records, Maps 4 and 5). The distant end of each runway was marked with a large 56 ft by 56 ft (17 m by 17 m) “X” so that aircraft would not mistake the bladed areas as active airstrips. The X’s were made of 4 ft by 8 ft (1.2 m by 2.4 m) sheets of plywood painted orange and white (Field Records, Map 4). A 60 ft (18.3 m) square rope and metal T-pole fence surrounded the plywood X. The markers on the central and northeast runway remain intact (Field Records, Photos 3 and 4).

BREN Tower Area

Besides the tower itself, a number of other structures and features occur in the immediate surrounding area. Some are associated with the Operation HENRE experiments while others are associated with later experimental programs including sonic boom research, gravity studies and laser tests. Those associated with the HENRE research include a bermed, concrete Control Bunker standing 100 ft (30.5 m) east of the tower and a small power substation 100 ft (30.5 m) east of the bunker. According to engineering drawings, at least two plywood brock houses, a Quonset hut, a winch, several concrete pads, a water tank, and a trailer also stood in the tower's immediate vicinity (Holmes & Narver 1966a). Only the foundation for the free-standing Quonset hut, a winch, and a couple of concrete equipment pads remain (Field Records, Map 6).

BREN Tower

BREN Tower is a 1,527 ft (465 m) tall skeletal steel structure, forming an equilateral triangle in plan, 10 ft (3.1 m) across each side (Field Records, Drawings 1, 2, 3, 4, and 5; Photos 5 and 6). The tower's vertical supports are solid, 8-inch (20.3 cm) diameter round high tensile-strength steel members. Horizontal and diagonal elements are steel angles combined to form T-sections. The tower is comprised of fifty-one 30-ft (10 m) long sections bolted together with steel gusset plates at all joints. Painted orange and white, the structure weighs approximately 345 tons (Dresser-Ideco 1961a, 1961b, 1961c, 1961d, 1965). The tower was designed by EG&G and H & N. It was built by the Dresser-Ideco Company, headquartered in Texas, but operating out of their Ohio and California offices for this project. This firm specialized in erecting tall radio and television towers (Haywood 2004).

A concrete pad, shaped in an irregular polygon, serves as the foundation for the tower and as support for the associated elevator equipment (Dresser-Ideco 1966a, 1966b) (see Field Records, Drawings 6 and 7). The main tower work area is a three-story high rectangular platform encircled by a steel railing (Dresser-Ideco 1961e, 1961f, 1961g). It is attached to the tower's north side at the 31 ft (9.5 m) level and is accessed by three flights of stairs on the tower's west side (Field Records, Drawings 8, 9, and 10; Photo 5). A crane is attached

to the platform's west end, and at the east end is a split steel door through which the payload elevator ascends. There are also a series of smaller work platforms located at 39 ft (11.9 m), 69 ft (21 m), 119 ft (36.3 m), 309 ft (94.2 m), 509 ft (155.1 m), 1,129 ft (344.1 m), and 1,499 ft (456.9 m). The smaller platforms were used to connect and disconnect the power and control umbilical cords at junction boxes at these heights (Haywood et al. 1965:17, 19, 22).

The tower supported two elevators: a payload hoist, which originally carried the unshielded nuclear reactors used for Operations BREN and HENRE (Field Records, Drawings 11, 12, and 13; Photo 7); and a two-person passenger elevator. The payload elevator ran up the outside of the triangular tower, through a framework of steel rectangles, 6 ft (1.8 m) wide by 7 ft-6 inches (2.3 m) deep (Dresser-Ideco 1961h, 1961i, 1961j). This elevator had a vertical speed of approximately 70 ft (21 m) per minute and could travel to a maximum height of 1,500 ft (457 m) and a minimum height of 10 ft (3.1 m) (Technical Director's Staff 1965:17). The hoist car is missing; only the elevator cage remains. The passenger elevator is a narrow enclosed capsule within the tower, with a small window and an accordion-like safety door (Dresser-Ideco 1961k) (see Field Records, Drawing 14). It could travel to the top of the tower at a vertical speed of about 100 ft (30 m) per minute. The certifications for both elevators have expired.

Both fixed and mobile electrical panel boxes stand adjacent to the structure. Located on the tower's east side, a large fixed panel supported a series of motor starters and control relays. These supplied power to the neutron source and its vacuum and cooling system (Technical Director's Staff 1965:22). An active power panel is located on the west side of the tower between the stairway to the work platform and the north leg of the tower. This panel supplies power to the hazard lights at the top of BREN as well as the platform lighting system.

A system of heavy braided-steel guy cables braces the tower and was designed to withstand winds in excess of 120 miles per hour (REECo 1966a:6). Four sets of cables extend in each of three directions to a total of 12 triangular concrete anchors (Dresser-Ideco 1966c, 1966d, 1966e, 1966f). The anchors are arranged in pairs (Field Records, Drawings 15, 16, 17, and 18; Photo 8). The lower half of the tower is guyed to a closer set of six anchors (3 pairs), while the upper half is guyed to the farther set. The total length of cable used to stabilize the tower is over 5.5 miles (8.9 km) (REECo 1966a, 1966b).

Currently, a variety of small steel structures and equipment stand in the vicinity (Field Records, Photo 9). Most notable are two sets of paired, 27 ft (8.2 m) high towers, one immediately adjacent to BREN, and the other approximately 200 ft (61 m) to the east. Six 10 ft (3.1 m) high steel platform stands and four 8 ft (2.4 m) post stands are located north of the tower as is a wooden light pole with three lights attached to a horizontal cross arm. A narrow concrete pad approximately 5 ft (1.5 m) wide and 50 ft (15.2 m) long is also located about 40 ft (12.2 m) north of the tower. There are numerous post-mounted electrical boxes and both mobile and fixed power panels in the area. Scattered debris includes coaxial cable, communications wire, insulated electrical cable, lumber, wood boxes, several wooden staircases, nails, bolts, washers, conduit, and rebar. With the exception of several of the

electrical panels and some of the debris, most of these materials appear to be related to the post-Operation HENRE scientific experiments.

Control Bunker

The Control Bunker is located approximately 100 ft (30.5 m) east of the BREN Tower (Maps 4 and 6). Built using a standard 21 ft (6.4 m) wide by 50 ft 4 inch (15.3 m) long by 10 ft 6 inch (3.2 m) high Quonset hut, the structure is covered with 10 ft (3.1 m) of earth. Its long axis is oriented east-west. An “L” shaped concrete tunnel leads to the single doorway on the east side of the hut (Field Records, Photos 11 and 12). The gently sloping concrete tunnel is 36 ft (11 m) long by 6 ft (1.8 m) wide by 7 ft (2.1 m) high. Its walls are made of 9-inch (22.9 cm) thick reinforced concrete and a 1-ft (30.5 cm) high parapet extends above the entrance to hold back the earth cover (Field Records, Drawings 19 and 20). The bunker was used for storage and its interior could not be accessed during the historical evaluation in 2006 (see Edwards and Goldenberg 2007). According to engineering drawings (Holmes & Narver 1966b; 1966c) and interviews (Auxier 2004; Haywood 2004), the bunker was divided into a series of rooms using moveable 3-inch (7.6 cm) thick metal partitions. At the time of the HENRE experiments, a hallway ran along the structure’s south side providing access to four separate rooms along the north side of the bunker and the single room at the west end (Field Records, Drawing 19; Photos 13 and 14). A small (5 ft x 5 ft [1.5 m x 1.5 m]) toilet room was located in the southwest corner of the easternmost room (Room 1). Room 1, the power distribution room, also held the air conditioning unit as well as the main power service and switches. The adjacent room, Room 2, was the instrument control room. This room housed the control panels to operate some of the experiment instrument stations. The remaining rooms held control panels to operate the HENRE reactor and monitoring equipment to track the reactor’s performance as well as monitoring and recording equipment. Recent access (March 2012) to the bunker, confirmed the overall accuracy of the original engineering drawings. Some limited modifications however, were made in the past. A wood partition with a door once divided the interior hallway between Rooms 3 and 4, but only a portion of the frame is still in place. The air conditioning/heating units have been removed along with the instrument station control panels and monitoring equipment. A wooden shelf had been added to the west wall of Room 4 and the east wall of the same room is covered with “graffiti” comprised of notes, diagrams, and phone numbers of project personnel and NTS facilities starting with Operation HENRE and running through the later Brilliant Pebbles experiments.

Engineering drawings indicate that the hut is built on a 24 ft (7.3 m) wide by 56 ft (17.1 m) long by 6 inch (15.2 cm) thick reinforced concrete slab. The walls are made of overlapping, corrugated galvanized metal panels bolted to arched steel ribs that span the width of the structure. A reinforced concrete shell, 52 ft 8 inches (16.7 m) long by 22 ft (6.7 m) wide by 11 ft (3.4 m) high, encapsulated the Quonset hut. Several ventilation pipes and multiple pipe sleeve conduits for the power and signal cables extend from the Quonset hut through the concrete shell and the earth cover. Prior to backfilling with the 10 ft (3.1 m) earthen covering, the entire structure’s exterior, including the concrete entrance tunnel, was “hot mopped” with an asphalt compound to make it waterproof.

Quonset Hut Foundation

In support of Operation HENRE, a freestanding Quonset hut was erected about 50 ft (15.2 m) southeast of the tower and 45 ft (13.7 m) southwest of the Control Bunker (Field Records, Map 6; Photos 15 and 16). It was used as work space for assembling and storing some of the instrumentation used for the HENRE experiments (Haywood 2004; Holmes & Narver 1966d). According to engineering drawings (Holmes & Narver 1966a), the hut (Building No. T-508) was brought in from Camp Desert Rock, an abandoned military training camp located just southwest of the main entrance to the NTS (Edwards 1997). Nearly identical in size and construction to the Quonset used for the Control Bunker, this hut was erected on a 4 inch (10.2 cm) thick reinforced concrete pad that measured 48 ft 2 inches (14.7 m) long by 20 ft 8 inches (6.3 m) wide. The long axis is oriented east-west. Threaded bolts, 1/2 inch (12.7 mm) diameter by 8 inches (20.3 cm) long, were embedded along the edge of the foundation every 4 ft (1.2 m) on center (Field Records, Drawing 21). The bolts were used to secure the steel base plate that anchored the arched-rib structural supports. The corrugated metal panels attached to the arched ribs. The hut was removed at some time in the past and only the foundation is left. Severed power supply conduits protrude from the northeast corner of the foundation. The base plate anchor bolts and portions of the Celotex gasket that sealed the hut's base plate to the concrete foundation are still visible. A length of metal weather stripping in the center of the foundation's east edge marks the former location of the doorway (Field Records, Photo 16).

Hoist Car Winch Foundation

A concrete and wood pad is located near the southwest corner of the Control Bunker (Field Records, Map 6; Photo 17). The pad is partially covered with earth so its exact dimensions could not be obtained, but it is at least 3 ft (0.9 m) wide by 6 ft (1.8 m) long with the long axis oriented north-south. Threaded bolts spaced 6 inches (15.2 cm) on center are embedded along the edge of the pad. Three 6 inch x 8 inch pieces of lumber abut the west edge of the concrete. According to the engineering drawings (Holmes & Narver 1966a) and historic photographs (Field Records, Photo 18), the massive winch that lifted the payload hoist car up the tower was anchored to this concrete foundation.

Electric Winch

The electric winch sits on an 8 ft (2.4 m) by 6 ft (1.8 m) wide concrete pad located just off the west end of the Control Bunker (Field Records, Map 6). The winch is bolted to an iron platform. Based on historic photographs of the Operation HENRE facilities, this winch is not associated with the HENRE experiments (Field Records, Photos 19 and 20). Currently it is grounded to one of the 27 ft (8.2 m) paired towers used for the post-1970 experimental programs.

Substation 28-1

Substation 28-1 is the primary power source for the BREN Tower Complex although some of the portable equipment and lighting ran off mobile generators. The substation is approximately 186 ft (56.7 m) east-southeast of the tower (Field Records, Maps 5 and 6). It is enclosed by 8 ft (2.4 m) high cyclone fencing with barbed wire outriggers on top (Field Records, Photo 12). The substation consists of two pole structures supporting the incoming overhead transmission lines, transformers, and a series of electrical panels and meters. A mobile air conditioning unit and a small flatbed trailer sit just north of the substation.

Operation HENRE Experiment Stations

Only five of the 11 experimental programs for Operation HENRE required structures or construction activities that left substantive physical remains. Program 1 needed the most extensive building preparations, while Programs 3, 5, 6 and 9 all involved some structures specifically designed and built for their experiments. Programs 2, 4, 7, and 8 entailed only temporary, portable ground-based or tower-based instrument stations which were removed at the conclusion of the experiment and left little if no physical footprint. Program 10 was a late addition to the HENRE protocol and only minimal information was found about its research objective and no data were found about its experimental methodology. Program 11 was classified (Haywood 2004). The numeric designations for the various research programs did not correspond to the sequence in which they were executed. Many of the experiments ran concurrently while others required multiple phases. Each of the research programs will be discussed below.

Program 1 Experiment Stations

The station and structures associated with Operation HENRE experimental Program 1 are an underground shelter, a variety of collimator detector stations, an analog Japanese House, building materials, concrete prisms, and a trailer revetment. Most were arranged along the central bladed runway (Field Records, Maps 4 and 5).

Underground Civil Defense Shelter (aka. Pipe Shelter)

An underground civil defense shelter is located approximately 400 ft (122 m) from the base of the tower (Field Records, Maps 4 and 5). Measurements were made in the shelter to determine the shielding effects provided by the amount of dirt covering the structure. Dirt thickness varied in 1-ft increments from zero to 3 ft (0.9 m). The main body of the shelter is constructed from galvanized corrugated metal culvert pipe approximately 8 ft (2.4 m) in diameter and 24 ft (7.3 m) long (Holmes & Narver 1966e, 1966f) (see Field Records, Drawings 22 and 23; Photo 21). The culvert pipe is oriented perpendicular to a radius from the tower. Access to the shelter is on the eastern end through a sloping crawl space made of a 20 ft (6.1 m) long section of 3 ft (0.9 m) diameter culvert pipe. A louvered wooden door covers the opening at the surface (Field Records, Photo 22). A vent opening in the top of the shelter provided access for the coaxial cables connecting the shelter's interior instrumentation with the recording devices in the Control Bunker. One of the cable troughs extending from

the shelter towards the Control Bunker remains in place (Field Records, Photo 23). The trough is made of 6 inch (15.2 cm) diameter PVC pipe supported by stacked lumber and metal cross legs. It elevated the cables approximately 3 ft (0.9 m) above the ground surface.

Free-Standing Collimator at 450 ft (137 m) from BREN Tower

Used to improve data resolution in neutron, X-ray, and gamma-ray optics, a collimator is a device that filters a stream of rays so that only those traveling parallel to a specified direction are allowed through to the detector or recording plate. Without the collimator, rays from all directions are recorded creating a blurred, unreadable image. Collimators were critical to obtaining viable data for the Program 1 dosimetry studies.

A single collimator sits on the ground surface, 450 ft (137 m) from the tower's base (Field Records, Maps 5 and 6). It is a standard 54 inch (137.2 cm) diameter by 54 inch (137.2 cm) long collimator with a hollow iron body and a 45° conical opening in one of its ends. Typically the opening is fitted with either a water-filled or lead insert that further reduced the opening to a 30° cone and secured detectors at the back of the cone. The detectors measured either neutron or gamma rays emitted from the source. A 5 inch (12.7 cm) diameter cylindrical opening extends from the conical opening along the central axis and through the rear of the collimator providing both access to the detector and a cable passageway.

The insert and detector have been removed from this collimator. The conical opening is oriented towards the southeast with the body facing the tower. A pair of cables is attached to one of the lifting lugs welded to the upper end of the body (Field Records, Photo 24).

Mobile Weather Station

Located 40 ft (13 m) southwest of the 88 ft (28.5 m) tower (described below in Program 3 Experiment Stations) is a mobile weather station (Field Records, Maps 5 and 6). According to Haywood (2004) and Auxier (2004), this may be the mobile weather station used during the Operation HENRE. The weather station consists of a 30 ft (9.1 m) high extendable mast with an anemometer, wind direction indicator and telemetry equipment. The mobile unit, positioned alongside the mast, contains other standard weather instrumentation. The two-wheeled mobile unit includes instruments to record temperature, barometric pressure, humidity and precipitation (Field Records, Photo 25).

Mobile Tower and Anchors

A mobile steel tower is located at approximately 970 ft (296 m) due north of the BREN Tower (Field Records, Maps 5 and 6). With its sections retracted for transport, the collapsible tower lies on a two-wheeled trailer (Field Records, Photo 26). Three steel anchors with the guy wires still attached are located about 30 ft (9.1 m) northwest of the trailer indicating that this tower once stood in this location. It is not clear if this tower was associated with the Operation HENRE experiments.

Turret-Mounted Collimators at 1,500 ft (457.2 m) from BREN Tower

The turret-supported collimators used for some of the Program 1 experiments were mounted on special concrete pads (Holmes & Narver 1962). The first pair of collimators was supported by an adjustable turret stand 1,500 ft (457.2 m) from the base of the BREN Tower (Field Records, Maps 4 and 5; Drawing 24). As described above, each collimator is a hollow, welded-iron cylinder 54 inch (137.2 cm) in diameter and 54 inches (137.2 cm) long (Field Records, Photos 27 and 28). Typically, the hollow area was filled with water to help further shield the detector from the effects of neutron-produced gamma rays striking the collimator from different angles. There is a fill-plug located in the body of the collimator. Only the easternmost collimator was used for the experiment at the 1,500 ft location. It was filled with borated water and wrapped with 5 inches (12.7 cm) of polyethylene sheeting for additional shielding. The western member of the pair was mounted to counterbalance the turret drive system. It was not wrapped with the additional polyethylene sheets. Instead of water, this collimator was filled with polystyrene beads some of which are scattered around the base of the turret. The conical openings of these collimators are oriented toward the tower. The detectors have been removed.

The turret's lateral movement is controlled by a horizontal bearing and a rotating plate. Vertical angles are changed by turning a crank and gear reduction system with a chain and sprocket drive to rotate the collimator in the vertical plane. The vertical angle can be adjusted from 0° (straight up) to 180° (straight down). The current orientation of this pair of collimators is facing BREN Tower with a downward vertical angle of 150°.

Originally, elevated wooden troughs held the coaxial data transmission and power cables that ran between the detectors and the recording bunker or trailers (Field Records, Photo 27). All of the troughs for this collimator station have been dismantled; however, scraps of wood and nails are scattered across the ground surface.

Pair of Free-Standing Collimators at 1,520 ft (463 m) from BREN Tower

A pair of standard 54 inch (137.2 cm) diameter collimators is located 1,520 ft (463 m) north of the BREN Tower (Field Records, Map 5; Photos 29 and 30). Each has a 45° degree conical opening in its upper surface to hold a detector (Field Records, Drawing 25). Both collimators are partially buried but oriented differently. The western member of the pair is oriented with the detector opening straight up. The collimator on the east is angled toward the tower. A collimator insert that reduced the angle of the conical opening to 30° sits on the ground surface about 20 ft (6.1 m) southeast of the pair (Holmes & Narver 1966g).

Free-Standing Collimator at 1,800 ft (458.6 m) from BREN Tower

This collimator is located 1,800 ft (458.6 m) north of the BREN Tower. It is 200 ft (61 m) west of the collimator arc (see description below) and on the same radius as the turret-mounted collimators (see description above). The collimator is partially buried with its upper surface angled toward BREN Tower. It is the same size as the others, but the conical

detector opening is plugged and a vent pipe protrudes from the bottom (Field Records, Map 5; Photos 31 and 32).

Collimator Row

A series of 10 collimators are arranged in a row 1,800 ft (548.6 m) from the base of the BREN Tower along a raised berm (Field Records, Maps 4 and 5). An 8-10 ft (2.4-3.0 m) wide bladed path runs behind the 6 ft (1.8 m) high raised berm. Spaced 20 ft (6.1 m) apart, the collimators sit on the ground surface and are oriented at different angles to the neutron source that was mounted on the tower (Field Records, Photos 33 and 34). The collimators are 54 inches (137.2 cm) in diameter by 54 in (137.2 cm) long. They have no additional shielding. The front/top face of the collimators does not have the typical 45° conical opening. Instead, the opening is approximately 6 inches (15.2 cm) in diameter with nearly vertical sides. The back/bottom face of each detector is solid. Any instrumentation would have been inserted directly into the opening on the front face. Each collimator bears a number identification on its body in white paint. The westernmost collimator is designated “#1” and the numbers run in sequence ending with number 10 on the east.

Instrument Tower

A 10 ft (3.1 m) high rectangular metal tower is located 150 ft (46 m) west of the analog Japanese House (see below) and 2,250 ft from BREN Tower. Its legs and cross braces are made of 6 inch (15.2 cm) diameter round steel members (Field Records, Map 5; Photos 35 and 36). A steel rung ladder at the southwest corner of the tower provided access to the platform. The instrument platform, built of I beams and wood and metal decking, is surrounded by a removable pipe rail and safety chain fence. A mounting plate and a gear system with a hand crank that allowed for vertical angle adjustments are attached to the center of the platform. Exactly what type of instrumentation the tower held is unknown. According to the Operation HENRE site plan (Holmes & Narver 1966h) and historic photographs (Field Records, Photo 35), a pair of turret-mounted collimators was erected at this location, 2,250 ft (686 m) from the base of BREN Tower. Photographs and descriptions indicate that the pair was identical to the turret mounted insulated collimator found at 1,500 ft (457.2 m) from BREN Tower (see description above). The collimators were replaced with the existing tower as part of one of the subsequent test programs (post-1966), but it is unknown whether it was one of later HENRE experiments or one of the post-1970 experimental programs.

Platform-mounted Collimators at 2,250 ft (685.8 m) from the BREN Tower

Another pair of collimators was set up at 2,250 ft (685.8 m) from the tower just west of the analog Japanese House (Field Records, Map 5). Instead of a turret mounting, this pair of standard 54 inch (137.2 cm) diameter by 54 inch (137.2 cm) long collimators was placed on a raised platform made of railroad ties stacked six courses high (Field Records, Photos 37 and 38). With the openings oriented straight up, each held a standard 30° lead insert making the effective angle about 63° between the neutron source and the detector. The

detectors, along with the lead inserts, were removed from the collimators following the conclusion of the experiments.

Analog Japanese House

Built specifically for the Operation HENRE experiments in Area 25, this building was identical to the Type A analog house built for the original Operation BREN experiments in Area 4. It is located approximately 2,250 ft (685.8 m) north of the BREN Tower (Field Records, Maps 4 and 5). This one story, gable-roofed frame building has a modified rectangular footprint (Field Records, Drawings 26 and 27). It measures 28 ft 4 inches (8.6 m) east-west by 22 ft 4 inches (6.8 m) north-south. The building is constructed primarily of unpainted wood 4-x-4 inch framing with 4-x-8 inch ceiling joists and 2-x-4 inch rafters. One-and-three-quarter inch thick "transite" (cement asbestos board) panels were used as cladding; many of these panels survive and are held in place by 3/4-inch wood stops. The building originally featured four exterior door openings, and 12 exterior window openings (all were openings only). Non-original plywood infill now covers all of the original window, exterior door and porch openings. Until recently, a plywood "Brock" house filled with fly ash to a height of four feet, stood immediately west of the building. The "Brock" house was not part of Operation HENRE and has been removed in compliance with environmental/hazardous material cleanup activities.

The east-west oriented gable roof slopes approximately 30° and features overhanging eaves. It is formed by 16 wood rafters; transite panels (many now missing) are contained between the rafters as cladding. A separate shed roof, starting just below the eaves of the main roof, spans across the south elevation.

The building rests on four sets of wooden skids rather than a foundation. These permitted the building to be repositioned. The skids each consist of seven 2-x-12 inch members, bolted together (with both one-inch round and 1/2 inch round bolts). Steel strap handles attach to the angled, southern end of the skids.

Exterior:

The north elevation (Elevation B, Holmes & Narver 1966i) consists of eight vertical bays of unequal widths (Field Records, Drawing 26; Photos 39 and 40). Originally, the elevation featured a doorway with a shed-roof cover at the third bay from the east, flanked by four window openings of varying size. The windows were all horizontally oriented, with two smaller openings, 3 ft 2 inches by 2 ft 3 inches (1 m x 0.7 m) and 2 ft 8 inches by 2 ft 3 inches (0.8 m x 0.7 m), east of the doorway and two larger ones, 6 ft 2 inches by 3 ft 3 inches (1.9 m x 1 m) and 6 ft 2 inches x 4 ft (1.9 m x 1.2 m), to its west. Plywood now covers all these openings. Transite panels remain in the spaces above and below the windows; only vestiges of the structure for the doorway's shed roof survive.

The south elevation (Elevation C, Holmes & Narver 1966i) is the longest side of the structure (Field Records, Drawing 26; Photos 41 and 42). The shallow "veranda" extends across most of the elevation; it is now in-filled by plywood. Flanking the veranda on both ends are original transite-clad solid walls, each one bay wide and with an intermediate

horizontal member. A doorway is cut into the plywood and currently serves as the primary entry. The wood skids project from under the floor joists.

The east elevation (Elevation D, Holmes & Narver 1966i) consists of a narrow shed-roofed portion and a projecting gable-roofed bay to the south, and the receding, taller, main gable end to the north (Field Records, Drawing 26; Photos 40 and 41). Exposed purlin ends project from the gable ends of both the main roof and that of the projection. The projecting bay retains all of its transite paneling – eight panels in the wall area and three in the gable end. The receding, main gable end wall features plywood infill over much of its wall surface, covering an area that was originally open. The northern end bay, as well as the gable end, retains their transite panels. The ends of the 4-x-6 inch floor beams extend beneath each vertical column at the projecting bay.

The west elevation (Elevation E, Holmes & Narver 1966i) is a seven bay wide gable end with projecting exposed roof purlins (Field Records, Drawing 26; Photo 41). It consists primarily of transite panels, divided by wood framing. Plywood in-fills a 6 ft 1 inch (1.8 m) wide by 4 ft (1.2 m) window opening occupying the northern half of the wall. Four bolts are visible at the center of the roof beam, the only bolted connections observed at the building's exterior superstructure.

Interior:

The interior is essentially an open floor plan (Holmes & Narver 1966j), with rooms suggested by partial walls and overhead beams (Field Records, Drawing 27; Photos 43 and 44). Two large spaces, a living room and a reception room, occupy most of the floor plate's southern two-thirds, with small spaces lining the east and west exterior walls. These smaller spaces include three closets along the west wall and two closets and a *toko* along the east. In a traditional Japanese house, a *toko*, short for *tokonoma*, was an alcove used for displaying art. The living room/reception room division is suggested by an overhead beam, suspended 5 ft 6 inches (1.7 m) above the floor.

The northern one third of the floor plate is occupied by three rooms, a dining room, kitchen, and toilet. A corridor and a vestibule open to the exterior via a 6 ft (1.8 m) by 6 ft (1.8 m) doorway (now plywood-covered), provided circulation.

Interior finishes consist of a plywood floor, wood-frame and transite walls, and a wood-frame and transite ceiling, essentially the underside of the roof. Most of the transite roof panels have fallen to the ground and the roof is now mostly open to the sky.

The interior is now filled with debris, including fallen transite, plywood, miscellaneous lumber fragments, plastic drum receptacles, and a ladder. Originally, the structure would have been filled with monitoring equipment. There were six dosimetry instrument stations located inside the house and two located to the rear of the house (Field Records, Drawing 27). One of the concrete prisms (described below) used for material shielding studies remains in place.

Concrete Prisms

A pair of right, regular, hexagonal concrete prisms was used for additional attenuation studies. One of the prisms is located inside the analog Japanese House (Field Records, Photos 45 and 46). The other is located adjacent to the Japanese building materials (described below). The hexagonal prisms are identical, measuring 3 ft (91 cm) high with each of the six faces 2 ft (61 cm) wide. Both prisms are made of borated concrete, used because of its enhanced shielding properties. Grooves to accommodate 1 inch (2.54 cm) diameter counter tubes are located on each face and the top of the prisms. Both prisms have been moved since the conclusion of the Operation HENRE experiments. The interior prism is located only a few feet from its original location inside the house. The second prism sits outside the house adjacent to the Japanese building materials (Field Records, Map 5).

Trailer Revetment

A trailer revetment is located 100 ft (30.5 m) behind (north) the analog Japanese House (Holmes & Narver 1966k). It is about 250 ft (76 m) long and 16 ft (4.9 m) wide (Field Records, Drawing 28; Photos 47 and 48). Both ends of the revetment widen to about 35 ft (10.7 m) and are inclined to provide vehicle access. A 3 ft (0.9 m) high berm parallels the south edge of the revetment. The central portion of the revetment is long enough (110 ft [33.5 m]) and deep enough (14 ft [4.3 m]) to accommodate three trailers. A fence constructed of metal fence posts with two strands of yellow rope runs along both the north and south sides of the revetment. A 1 ft (30.5 cm) high dike surrounds the revetment to prevent flooding.

Japanese Building Materials

Three wooden crates full of authentic Japanese building materials are situated approximately 30 ft (9.1 m) northeast of the analog Japanese House (Field Records, Map 5). Located near the fence that surrounds the trailer revetment (see description above), the crates contain imported ceramic roof tiles, rope, and oyster shell packed in straw (Field Records, Photos 49 and 50). A separate stack of roof tiles sits adjacent to the house's east elevation. The building materials were tested during the dosimetry studies. A variety of detectors were placed in and around the crates to obtain attenuation rates for the different materials. These data were used in the refinement of the human dose rate calculations.

Triangular Steel Tower Sections

Adjacent to the west side of the analog Japanese House sits a stockpile of triangular steel tower sections (Field Records, Photo 51). There are a total of 12 sections and each section is about 20 ft (6.1 m) long and 3 ft (0.9 m) on each side. The sections appear to be of about the same age as the other Operation HENRE structures, but the purpose or original location of these tower sections is unknown. The tower sections do not appear in historic photographs of this area taken during Operation HENRE.

Circular Pit

A shallow circular pit is situated 1,580 ft (482 m) north of the BREN Tower (Field Records, Map 5). The pair of free-standing collimators (described above) is about 60 ft (18.3 m) southwest of the pit and the collimator row (described above) lies 220 ft (67.3 m) to the north. The depression is 3 ft (0.9 m) deep and measures about 30 ft (9.1 m) north-south and 20 ft (6.1 m) east-west (Field Records, Photo 52). No other structures, features or debris were found in the vicinity. The pit does not appear on the Operation HENRE site plan and it was not mentioned in any of the literature for the post 1970 experiments.

Program 2 Experiment Stations

The Program 2 experiments required only a recording trailer and a series of eight temporary ground-based instrument stations. The recording trailer for this program utilized the trailer revetment built for the Program 9 experiments (see description below). The Program 2 instrument stations were small shielding enclosures equipped with various sensors. The stations were located along the N 49°W radius from the tower at distances of 30 ft (9.1 m), 400 ft (122 m), 700 ft (213 m), 800 ft (244 m), 850 ft (259 m), 1,200 ft (366 m), 1,600 ft (488 m), and 1,700 ft (518 m). These instrument stations have been removed and the only evidence of their former location is an occasional stake or piece of rebar.

Program 3 Experiment Stations

The experiments for Program 3 were designed to gather data on neutron and gamma dose rates in relation to the point of detonation of a nuclear weapon. Facilities for the Program 3 experiments included a trolley system and a suspended instrument platform, three permanent 150 ft (46 m) towers, 1 portable tower, and a series of rectangular foxholes.

Instrument Phantom Platform

One of the experiments for Operation HENRE Program 3 utilized a trolley system attached to the BREN Tower guy wire cables (Holmes & Narver 1966l, 1966m). The trolley system consisted of several pairs of pulleys and an electric hoist that allowed various instruments to be suspended at different heights near the base of the tower (Field Records, Drawings 29 and 30; Photo 53). The instruments were lifted into the air by utilizing a 3-armed phantom platform made of aluminum (Field Records, Photos 54 and 55). The trolley system has been removed, but the instrument phantom platform was left approximately 150 ft (46 m) southeast of the underground civil defense shelter (Field Records, Maps 5 and 6). The platform is 5 ft (1.5 m) in diameter and has 3 light-weight aluminum support arms. Cables were attached to all three arms to keep the platform level (Holmes & Narver 1966i).

Tower 3.1

Located 1,150 ft (351 m) from the base of BREN Tower on the N 35° E radius, Tower 3.1 is a 150 ft (46 m) triangular steel tower mounted in a concrete base. It is one of the three permanent towers erected for Program 3 (Holmes & Narver 1966n) (see Field Records,

Map 5; Drawing 31; Photos 56 and 57). The tower is stabilized by three sets of five guy wires attached to heavy eye bolt anchors. It has a hand-cranked winch and pulley system that allows the raising and lowering of a cable attached at the 150 ft (46 m) level. This cable extends to the east leg of the BREN Tower. A wooden placard at the base of the tower provides contact telephone numbers and experimental station identification

Tower 3.2

Tower 3.2 is 1,000 ft (305 m) northeast of Tower 3.1 and 2,150 ft (655 m) from the base of BREN Tower on the N 35° E radius (Field Records, Maps 4 and 5). Like the first tower, Tower 3.2 is 150 ft (46 m) high, triangular in cross-section and made of steel (Field Records, Photo 58). It too has a hand-cranked winch and pulley system that allows the raising and lowering of a cable attached to the top of the tower. This cable extends to Tower 3.1.

Tower 3.3

Located 1,000 ft (305 m) northeast of Tower 3.2 and 3,150 ft (960 m) from the base of BREN Tower on the N 35° E radius (Field Records, Maps 4 and 5), Tower 3.3 is identical to Towers 3.1 and 3.2. It is 150 ft (46 m) high triangular steel tower mounted in a concrete base. The hand-cranked winch and pulley system raises and lowers a cable attached at the top of the tower. This cable extends southwest to Tower 3.2. A wooden placard at the base of the tower provides its experimental station identification and contact phone numbers (Field Records, Photos 59 and 60).

88 Foot Tower

Located approximately 650 ft (198 m) north of the Control Bunker and 750 ft (229 m) from the BREN Tower, the 88 ft (22.8 m) tower is constructed of telescoping triangular metal sections (Field Records, Maps 5 and 6; Drawing 32; Photo 61). Each section is secured to the adjoining section(s) with bolts and metal strapping. This particular model (# HS-588) was manufactured by the Tri-Ex Tower Corporation. The tower is approximately 4 ft (1.2 m) on each side at the base and tapers to 1 ft 6 inches (0.5 m) on each side at the top. Power cables run through galvanized conduit on the west side of the tower extending from the base to the pair of red hazard lights at the top. Two duplex receptacles (outlets) are spliced into the power cable, one 4 ft (1.2 m) above the base of the tower and the other about 8 inches (20.3 cm) below the top of the tower. Instrument cable runs down the east leg of the tower and extends to the Control Bunker (Holmes & Narver 1969). The tower is secured with three ground anchors and three pairs of guy wires.

Rectangular Foxhole Area

A total of 12 rectangular foxholes of various sizes were excavated along two arcs, one approximately 120 ft (36.6 m) from the base of BREN Tower, and the other at 136 ft (41.5 m) (Holmes & Narver 1966a, 1966o). Six foxholes were oriented with the long axis parallel to a line between the foxhole and the source, while the other six were arranged perpendicular to this line (Field Records, Maps 8 and 9; Drawing 33; Photos 62 and 63).

All the foxholes were 2 ft (61 cm) wide but varied in length and depth. Lengths ranged from 5 ft (1.5 m) to 11 ft (3.4 m). Depths ranged from 4 ft (1.2 m) to 7 ft (2.1 m). The foxholes were plywood lined and had 2 by 6 inch (5.1 by 15.2 cm) shoring (Field Records, Drawing 34). The foxholes were covered with a 2 inch (5.1 cm) thick polyethylene cover. Each of the foxholes was instrumented with a series of detectors capable of producing a thermal neutron profile. A rope and metal T-post fence surrounded the area. Only a few scattered metal fence posts remain. The rectangular foxholes are no longer visible. Either they were filled in at the conclusion of the experiment or covered over during one of the later projects conducted at the BREN Tower location.

Program 4 Experiment Stations

Operation HENRE Program 4 was designed to gather data for a comparative study with the original 1962 BREN experiments on fast neutron flux attenuation. Researchers from Lawrence Radiation Laboratory developed the Program 4 experimental methods to investigate distance dependence between different types of neutron sources.

Program 4 required only an unspecified number of instrument stations located at various distances from BREN Tower. The stations consisted of small devices to measure neutron flux. The devices were collected at the conclusion of the experiment and the only physical evidence remaining that might suggest their former location is an occasional wooden or rebar stake.

Program 5 Experiment Stations

The experiments conducted for Operation HENRE Program 5 focused on the attenuation properties of various types of open and closed field fortifications for the Nuclear Defense Laboratory in Aberdeen, Maryland.

Cylindrical Foxhole Area

The structures associated with the Program 5 Field Fortification experiments consist of a series of 10 open and covered cylindrical holes in the ground (Field Records, Maps 5 and 6; Drawings 33 and 34; Photos 64 and 65). Nine are arranged in three sets of three 6 ft (1.83 m) deep foxholes at horizontal distances of 27 ft (8.2 m), 54 ft (16.5 m), and 108 ft (32.9 m) from the base of BREN Tower. A single foxhole is located at 8.8 ft (2.7 m) from the tower, almost directly below the hoist car that once held the Operation HENRE neutron source. Measuring 4 ft (1.22 m) in diameter and 6 ft (1.83 m) deep, each hole is surrounded by a 1 ft wide (0.3 m) concrete collar with a U-shaped trough. The collars, set flush with the ground surface, provided a stable surface for the concrete covers used on selected holes, while the trough held instrumentation cables for the various detector equipment placed inside. Panels of 1/4 inch (6.4 mm) thick masonite originally lined each of the holes and all had interior plywood shoring (Holmes & Narver 1966o).

The two easternmost foxholes in each set are capped with the concrete covers. The covers are 6 ft (1.83 m) in diameter and either 3 inches (7.6 cm) thick or 6 inches (15.2 cm) thick.

The center foxhole in each set is capped with the 3 inch thick cover while the eastern foxhole has the 6-in cover. The single foxhole at the tower base is currently covered, but was alternately configured both open and closed during the Operation HENRE experiments. Each cover has a pair of rebar lugs or handles embedded in its surface (Holmes & Narver 2965a). The lugs are spaced 5 ft (1.5 m) apart (Field Records, Drawing 35). A mobile gantry used these lugs to lift and position the covers. There is a pile of three additional concrete covers located just west of the tower base. The open foxholes have been filled in with earth, but portions of the collars are visible (Field Records, Photos 66-68).

Program 6 Experiment Stations

Program 6 was sponsored by the AEC Health and Safety Laboratory, New York Operations Office and centered on measuring the neutron spectrum emitted by the HENRE source.

Instrument Station Enclosures

Like Program 4 (discussed above), the experiments for Program 6 required an unspecified number of instrument stations located at various distances from BREN Tower with some along the N 27°W line and others directly under the tower (Field Records, Maps 4 and 5). The emulsion packs used for this test program were placed on 3 ft (0.9 m) high aluminum tripods anchored to tent stakes driven into the ground (Sanna et al. 1969). The emulsions were collected at the conclusion of the experiment and all of the tripods removed. However, six of the enclosures for the stations along the N 27°W line remain intact. Each consists of a 6 ft by 6 ft (1.8 m by 1.8 m) fence of rope with metal T-posts at the four corners (Field Records, Photos 69 and 70). A series of three wooden tent stakes is embedded in the ground along both the north and south sides of the enclosure. No other physical evidence remains for Program 6.

Program 7 Experiment Stations

The instrumentation and facilities for this experiment, which focused on the empirical validation of a methodology for determining neutron cross sections and neutron-flux spectra, were minimal. Foil emulsions and sulfur pellets were either placed on the ground directly below the BREN Tower or on 40 inch (1 m) high instrument stands 27 ft (8.2 m) from the base of the tower. The emulsions and pellets were removed immediately after the conclusion of the experiment. The instrument stands were also removed. No physical remains could be associated with the Program 7 experiments.

Program 8 Experiment Stations

The instrumentation for Program 8 consisted of a series of primary and secondary detecting stations that utilized miniature tissue-equivalent ionizing chambers, film and foil emulsions, thermoluminescent detectors and spectrometers. These were mounted at various levels on BREN Tower or on temporary, portable stands surrounding the tower and were

removed at the conclusion of the tests. No physical evidence remains for the Program 8 experiments.

Program 9 Experiment Stations

The Program 9 experiments were located within a 200 ft (61 m) wide smoothed and stabilized runway that extends from BREN Tower on the N 55°W line for approximately 2,000 ft (610 m). These included a concrete turntable, a trailer revetment, and a two-pole wooden tower and winch.

Turntable

The turntable station is a circular, concrete vault fitted with a revolving mechanism that allowed for the 360° horizontal rotation of a concrete turntable (Holmes & Narver 1965b). It is situated 406 ft (124 m) from BREN Tower (Field Records, Maps 4, 5 and 6). The vault is 11 ft (3.4 m) in diameter and 5 ft (1.5 m) deep. It has a 2 ft (0.6 m) wide concrete collar (Field Records, Drawings 36 and 38). The rotating mechanism, positioned in the vault below the concrete turntable slab, is hidden from view. The turntable consists of an 8 inch (20.3 cm) thick concrete slab (Field Records, Photos 71 and 72). Three small 1 1/4-inch (3.2 cm) diameter holes have been drilled through the slab to allow access to the turntable leveling screws located near the bottom of the vault. A 3 ft (0.91 m) high by 4 ft (1.2 m) long metal bracket is attached to the turntable. This bracket secured the equipment being tested (the Radiological Armored Pod or RAP) and held it in a variety of configurations. Degree markings are painted onto the turntable (Field Records, Photo 73). These allowed for the proper alignment of the RAP with the neutron source on the tower. Controls for the rotating mechanism are on the south side of the turntable. Three electrical outlets for the detectors and other instrumentation surround the vault's perimeter.

Wooden Tower and Winch Facility

The winch facility experiment station for Program 9 is located in the stabilized area exactly 1,000 ft (305 m) from the tower base (Field Records, Maps 4, 5, and 6). It consists of a pair of 100 ft (30.5 m) high, tapered wooden poles made of western red cedar (Field Records, Drawing 37; Photos 74 and 75). The poles are spaced 12 ft (3.7 m) apart and are joined at the top by a pair of 10 inch (25.4 cm) wide by 3/8 inch (0.95 cm) thick metal straps with blocking in the center. To stabilize the wooden tower, three pairs of braided steel guy wires extend from the 75 ft (21.3 m) level to ground anchors. Four detector cable hangers are mounted on the poles 32 ft (9.8 m) above the ground. Originally, there was a series of cables that held a 1 ft (30 cm) thick by 5 ft (1.5 m) square polyethylene slab that supported three detectors (Holmes and Narver 1966p). The slab, detectors, and some of the cables have been removed. The slab was raised and lowered using the winch mounted on the concrete pad located about 8.5 ft (2.6 m) east of the poles (Holmes and Narver 1967). The concrete pad is 4 ft (1.2 m) wide by 6 ft (1.8 m) long by 1 ft (0.3 m) thick. The winch, a 1 horsepower electric hoist, Beebe model #1800A, is still attached to the pad with four heavy anchor bolts (Field Records, Drawing 38; Photo 76). A fence of metal T-posts and rope surrounds the experiment area. There are several metal warning signs (yellow with black

lettering) scattered on the ground along the fence line. The lettering is too faded to read. The recording instrumentation for this experiment was located in a trailer parked in a covered revetment located 250 ft (76.2 m) south of the wooden tower (see description below).

Trailer Revetment

An excavated trailer reinforced revetment oriented perpendicular to BREN Tower is located 750 ft (229 m) from its base (Field Records, Maps 4, 5, and 6). The revetment is approximately 250 ft (76.2 m) long, 16 ft (4.9 m) wide, and 14 ft (4.3 m) deep at the center (Holes & Narver 1966q). Both ends of the revetment widen to about 35 ft (10.7 m) and are inclined to provide vehicle access. A 3 ft (0.91 m) high berm parallels the south edge of the revetment. The center portion of the revetment was covered. The cover consists of steel I beams and heavy wooden beams sheathed in 3/4-inch (19 mm) thick plywood. For additional shielding from the neutron source, a thick layer of dirt blanketed the plywood roof deck. Wall supports were heavy timbers sheathed in 1-by-6 inch (2.54-by-15.24 cm) boards (Field Records, Drawing 39). At the time of the HENRE experiments, two recording trailers were parked under the cover. The revetment was built for Program 9, but the Program 2 recording trailer also utilized the space. The cover, which was approximately 3 ft (0.91 m) higher than the surrounding ground surface, has collapsed into the revetment trench (Field Records, Photo 77). A two-strand rope and metal T-post fence extends along the north and south sides of the revetment. The fence posts are 3 ft 6 inches (1.07 m) high. The rope is broken in numerous locations. A few metal warning signs still hang from the fence.

Program 10 Experiment Stations

This program was added after the HENRE operational plan was finalized making it difficult to determine the nature of facilities associated with these experiments. Information obtained from the Auxier and Haywood interviews (2004) indicate that the Program 10 experiments primarily involved instrumentation that was removed immediately following the conclusion of the experiments. Neither Auxier nor Haywood remember any facility being built exclusively for Program 10, although the British sponsored project may have utilized several detection stations erected for the other experimental programs. Both men recall that the British researchers used a mannequin torso nicknamed "Tyrone" for some of the dosimetry studies. No structures or features were identified for this program.

Program 11 Experiment Stations

Program 11 was classified. No information was found on the nature of the experiments or the facilities required.

Remote Support Facilities

At the time of Operation HENRE experiments (c. 1966-1969), there were a number of structures located at the Cane Spring Road entrance to the BREN Tower Complex (Homes

& Narver 1966k). These included a graded area with support trailers, a power substation, and a landing area for helicopters (Field Records, Maps 4 and 5).

Trailer Park

The main office trailer park and parking area for the Operation HENRE activities were located at the southeast corner of the intersection of Cane Spring Road and the access road to BREN Tower (Field Records, Map 6). Situated approximately 6,400 ft (1,950 m) from the BREN Tower, this facility consisted of a 160 ft (48.8 m) wide by 200 ft (61 m) long graded area (Holmes & Narver 1966r, 1966s). During the operation, this area housed a 5,000 gallon water tank and pump distribution system; toilet facilities with a septic tank and leach field; at least five support trailers; several mobile generators; and a power distribution system for the crossing arm access gate, the overhead lights and the office trailers from various organizations (Field Records, Drawings 40 and 41). The only structure still in place is the crossing arm gate (Field Records, Photos 78-81). However, this is not the original Operation HENRE gate.

Substation 28-2

This is a secondary substation that delivered power to the trailer park. It is supplied via an underground power line (Field Records, Map 5). The substation is surrounded by an 8 ft (2.4 m) high cyclone fence with three-strand barbed wire outriggers on top. The power distribution panel for the trailer park sits outside the enclosure on the north side (Field Records, Photo 82). The panel is still active.

Helicopter Landing Pad

Located just south of the trailer park, an area was graded and leveled for a helicopter landing area (Field Records, Maps 4 and 5). It measures approximately 150 ft (45.7 m) north-south by 150 ft (45.7 m) east-west. A graded access road, 250 ft (76.2 m) long by 20 ft (6.1 m) wide, connects the north edge of the landing area with the trailer park. Another graded dirt road connects the landing area to the paved main road leading to BREN Tower. The dirt access road is 20 ft (6.1 m) wide by 80 ft (24.4 m) long.

PART III. HISTORICAL INFORMATION

On July 16, 1945, the United States government detonated the first atomic weapon. The successful detonation of this test device, known as Trinity, led to the immediate plans for combat use of these weapons. It was the culmination of the Manhattan Project, America's massive scientific effort to develop a nuclear weapon to sway the outcome of World War II and the post-war balance of power (Rhodes 1995; Tlachac 1991a, 1991b). Less than three weeks later, a nuclear weapon exploded over the Japanese city of Hiroshima. A second weapon fell on Nagasaki three days later. World War II was effectively ended when the Japanese responded by surrendering on August 15, 1945.

The combat use of nuclear weapons had momentous consequences for both the Japanese blast survivors and the future direction of U.S. military policy. At the time, the effects of nuclear radiation were virtually unknown and no method existed for accurately calculating the radiation doses received by the blast survivors. There was critical need to investigate the short-term and long-term effects of radiation exposure. In addition, the bombing exacerbated already strained relations between the U.S. and the Soviet Union, eventually leading to the Cold War nuclear arms race. In the face of mounting tensions, military strategists needed to know how radiation might affect combat troops.

To address the serious health questions, U.S. medical teams began their studies of radiation effects in Japan shortly after the 1945 events (Cannan 1964). In 1947, the U.S. established the Atomic Bomb Casualty Commission (ABCC) as a permanent medical survey-research organization with offices in Hiroshima and Nagasaki (Auxier 1964:1; 2004). The ABCC continues its research with the Radiation Effects Research Foundation, a private nonprofit Japanese organization supported jointly by the U.S. and Japan. It maintains a comprehensive program to document and analyze the effects of nuclear radiation on the atomic bomb survivors and their offspring.

Concurrently with the ABCC's radiation effects research, the U.S. expanded its nuclear weapons development program. Initially, the weapons testing program was confined to sites in the South Pacific. However, logistical problems, increasing U.S.-Soviet tensions, and the outbreak of conflict on the Korean peninsula eventually led to the establishment of a continental test site. Carved out of land used by the Las Vegas-Tonopah Bombing and Gunnery Range in December 1950, the Nevada Proving Ground became the primary site for the U.S. nuclear testing program. Testing began in January 1951 and continued for the next 41 years. Renamed the Nevada Test Site (NTS) in 1955, the nuclear research and testing program carried out at the NTS were fundamental to weapons development, radiation fallout studies, and radiation exposure experiments (Titus 1986).

The objectives of the ABCC researchers and military policy makers coalesced in a series of tests beginning in the mid-1950s. In 1955, Operation Teapot included a series of experiments focused on weapon radiation fields. Data from these experiments indicated the possibility of accurately describing radiation fields from the Hiroshima and Nagasaki detonations. As a result, a survey group visited the ABCC in Japan with the objective of determining the feasibility of a dosimetry study. Because records showed that a significant

percentage of the survivors were in their homes at the time of the blast and because of the structural uniformity of Japanese houses, the survey group determined that the emphasis of the study should be placed on this group of survivors and the shielding characteristics of their homes (Auxier 1964).

Project Ichiban was the result of the survey group's recommendations. Initiated in 1956 by the Civil Effects Branch of the AEC's Division of Biology and Medicine, the Health Physics Division of the Oak Ridge National Laboratory ran the project. In addition to Operation BREN, the project included above-ground nuclear tests, laboratory experiments, physical surveys in Japan, and calculation studies. The purpose of the project was three-fold: 1) to document survivor location at the instant the bombs were exploded; 2) to establish radiation air-dose curves; and 3) to analyze shielding factors for houses (Auxier 1964:2-5).

Initial tests on Japanese-style houses were included in Operation Plumbbob in 1957. For these tests, two replica Japanese houses were constructed at the NTS from materials imported from Japan. After the Plumbbob tests, laboratory studies determined cement-asbestos board, a commercially available building material, to have shielding coefficients similar to traditional Japanese materials. Future tests, including the original BREN experiments in Area 4, incorporated "radiation analogs" of Japanese houses, built of cement-asbestos board on wood frames (Auxier 1964:5-8). Operation Hardtack II, in 1958, continued the dosimetry research using analog houses during atmospheric nuclear tests. While neutron data from the experiments were satisfactory, the gamma radiation data were inconsistent with previous studies. Consequently, Operation BREN was conceived as a definitive study of neutron and gamma radiation fields using an unshielded reactor as a point fission source (Auxier 1964:13; 1977).

Previous radiation studies involved atmospheric tests and follow up experiments had been planned using atmospheric detonations, but were interrupted by the 1958-1961 testing moratorium (Auxier 2004). Although the BREN tests were not actually conducted until after the moratorium was lifted, planning occurred while it was in effect.

Phase I of Operation BREN in Area 4 began at the NTS in March of 1962. The tower supported an unshielded reactor, positioned at various heights in the vicinity of the analog Japanese houses. Data collection involved numerous measurements of the neutron and gamma radiation emissions from the reactor. These were made both inside and outside the analog houses to investigate the shielding properties of the buildings. The second phase of the project began in June 1962. The reactor was replaced with a 1,200 curie Cobalt 60 source and the dosimetry measurements were repeated. The experiments were extremely successful. According to the official project report:

In addition to improved shielding information for houses, significant contributions were made to the description and understanding of the radiation fields from nuclear weapons and other intense radiation sources for large distances (Auxier 1964:18).

The success of the BREN experiments spurred interest in additional research programs. The technical concept for Operation HENRE was first proposed in 1964 shortly after the analysis of the data from the BREN experiment (Haywood and Auxier 1965). Intended as a follow-up study to fill data gaps in the previous dosimetry investigations, Operation HENRE in Area 25 involved the use of a neutron source with an energy level that would allow investigation of the neutron-air interaction (Technical Directors Staff 1965; Provenzano et al. 1966). The 14-Mev neutron source, designed and built at ORNL, utilized the BREN Tower to hoist the source to various heights where it would produce a continuous high intensity source of neutrons when in operation. An extensive program of field experiments was planned with the neutron source scheduled for about 30 operating sessions, each four hours in duration (Butler and Haywood 1971).

The HENRE test program was initially planned for execution in the second half of 1965, but the operation was delayed when NTS engineers expressed concern that the tower could not withstand the vibration from pending underground nuclear tests in Area 4 (Reeves 1966). In 1966, the tower was moved to Area 25, about 20 miles south-southwest of its original location. Only the tower was relocated. The Area 4 support buildings remained in place. The tower was erected on a new concrete foundation and supported by a series of paired guy-wire stanchions. A new Control Bunker was built along with a few small support buildings and a power sub-station. The other structures erected were linked to the various Operation HENRE experiments.

Originally, nine different experimental programs were proposed for Operation HENRE. A tenth program was added later (Hollingsworth 1966) and there was an eleventh classified program (Haywood 2004). These investigations were extensions of earlier work sponsored by the Civil Effects Test Organization (CETO). They included general radiation propagation studies, shielding investigations, neutron field induced-activity studies, attenuation measurements, field fortification shielding analyses, emulsion spectrometry, high-energy neutron cross-section and flux-spectra determinations, tissue-equivalent depth-dose measurements, and radiological armor design testing. Groups conducting the experiments included researchers from ORNL, EG&G, the Ballistics Research Laboratory (BRL), the U.S. Naval Radiological Defense Laboratory (NRDL), Lawrence Radiation Laboratory (LRL), Nuclear Defense Laboratory (NDL), the AEC Health and Safety Laboratory (HASL), the Air Force Weapons Laboratory (AFWL), the Armed Forces Radiobiology Research Institute (AFRRI), the U.S. Main Battle Tank Group (USMBT), and the U.K. Atomic Weapons Research Establishment (AWRE).

All of the proposed research studies involved expanding current knowledge on the effects of a nuclear detonation on human populations as well as identifying and improving materials and methods that would mitigate exposure to radiation. Program 1 was the most extensive research program planned for Operation HENRE. Sponsored by ORNL, Program 1 focused on spectrometry and angular distribution measurements as a function of distance, free-field total dose measurements, and air-ground interface effects. These data were critical to developing accurate dose-rate calculations for the survivors of Hiroshima and Nagasaki as well as dose rates for other types of radioactive exposures (Cheka 1969; Thorngate et al. 1969).

Program 2, developed by the BRL, focused on measuring spectra and gamma dose transmission for idealized shielded enclosures (Hollingsworth 1966:4; Technical Director's Staff 1965). In contrast, the experiments for Program 3 were designed to gather data on neutron and gamma dose rates in relation to the point of detonation of a nuclear weapon as well as examine the thermal neutron profile in soil. The rectangular foxholes used for a portion of the Program 3 experiments were instrumented to record soil moisture content and thermal energy. The NRDL was the proponent for this research (Burson 1971).

Operation HENRE Program 4 was designed to gather data for a comparative study with the original 1962 BREN experiments on fast neutron flux attenuation. Researchers from LRL developed the Program 4 experimental methods to investigate distance dependence between different types of neutron sources. They were primarily interested in attenuation as a function of slant range and source height to help better calculate exposure rates from a nuclear detonation (Hollingsworth 1966; Technical Director's Staff 1965).

The experiments conducted for Operation HENRE Program 5 focused on the attenuation properties of various types of open and closed military field fortifications for the ND. A series of 10 concrete-lined foxholes were instrumented to identify the effectiveness of different configurations of field fortification shielding (Rexroad and Jacobson 1973).

The HASL developed Program 6 to investigate neutron spectrometry with nuclear emulsion films. The data collected were to be compared with theoretical calculations in order to resolve difference between experiment and theory. The experiment was also designed to test the reliability and reproducibility of the emulsion system used for the measurements (Sanna et al. 1969). The AFWL's Program 7 gathered data on high energy neutron cross-sections for use in developing new military equipment with better radioactive shielding characteristics. While Program 8, sponsored by the AFRRI, focused on measuring human dose rates by using tissue-equivalent phantoms. Phantoms were made of materials like paraffin or plastic and served as analogs to approximate the physical properties of human tissue. The data derived from these studies would help the military better prepare for potential exposures to its forces.

The experiments conducted for Operation HENRE Program 9 focused on the confirmation of design methods and techniques used in the development of radiological armor for the USMBT in a joint program with the Federal Republic of Germany. In addition, this program also looked at differential measurement of fast-neutron air-ground interface effects, another component that would help develop better shielding properties for military vehicles in case of radiological exposures (French and Mooney 1971).

Program 10 was added to the HENRE experiments after the operation began in 1966. This program involved British researchers from the AWRE interested in investigating neutron dose depth measurements, dosimetry response studies, spectra measurements, instrument characteristics, and neutron activation in selected materials (Hollingsworth 1966).

Facilities built to support all of the Operation HENRE experimental programs included steel and wooden towers, stationary and movable collimating devices, various above and

below ground field fortifications, detector stations, and a single replica Japanese-style house patterned after the Type A structure used in the Operation BREN experiments (Technical Director's Staff 1965).

The Operation HENRE experiments got underway in the spring of 1967. The neutron source operated on a regular schedule through the summer and fall until the experimental programs were complete. Researchers associated with the program viewed the experiments as extremely important and deemed the operation a success (Auxier 2004; Haywood 2004). Indeed, data from the two BREN Tower operations, combined with other Ichiban data sets, became the basis for a dosimetry system called the Tentative 1965 Dose (T65D), used to estimate radiation doses received by individuals (Auxier 1977). The T65D estimates were used until the mid-1980s when they were replaced by a new dosimetry system (DS86) based on the Monte Carlo method of dose rate calculation (Tajima and Christy 1986). However, the BREN Tower data are still used for verification of the validity of the DS86 model.

Later Uses

The neutron source and most of the instrumentation were removed after Operation HENRE concluded in the fall of 1968. The tower, its support facilities and the associated experiment stations, however, continued to stand in Area 25. Because the hoist car and elevator remained operational, the tower was used for a variety of other purposes over the next two decades. Various projects including laser scintillations experiments, small missile launch tests, sonic boom research, and meteorological experiments (Cormier 1975; Cornett and Brundidge 1970) were conducted at the BREN Tower site (Nevada Test Site 1976). The two most recent uses of the tower involved gravity research and a tethered flight test program.

The National Aeronautical and Space Administration (NASA) sponsored two successful series of sonic boom research studies at the BREN Tower Complex. The first series was conducted in August 1970, while the second tests concluded in October of the same year (REECo 1970; U.S. AEC 1970a, 1970b). The research focused on gathering basic data concerning the generation and propagation of sonic booms and the impact of various meteorological conditions. The program required wind velocity and direction information recorded from 10 weather stations positioned at various heights on BREN Tower as well as a nearby 100 ft (30.5 m) supplementary tower (Kane 1973:395). Other instrumentation included an extensive microphone array both on the tower itself and at field locations surrounding the tower (Holmes & Narver 1970a, 1970b). In addition to BREN Tower, researchers also utilized some of the existing Operation HENRE support buildings for staging the experiments (Field Records, Drawings 42 and 43; Photos 83-86).

BREN Tower was also the site of a pair of laser research projects conducted by the Stanford Research Institute (SRI) and technical personnel from EG&G. The purpose was to gather data for the development of a laser eye-safety manual for the U.S. Air Force School of Aerospace Medicine at Brooks Air Force Base, Texas (REECo 1971; U.S. AEC 1970c, 1971). The project, conducted in the fall of 1970 and the summer of 1971, utilized a pair of

tower-mounted lasers and a truck-mounted laser. The tower lasers were aimed at receivers on the truck and the truck-mounted laser was directed at receivers on BREN Tower. To facilitate measurements at different distances and angles, the truck was moved to various positions along the Operation HENRE Program 3 instrument runway with the three 150 ft (46 m) towers (Field Records, Maps 4 and 5).

In the late 1980s, a group of researchers from Lawrence Livermore National Laboratory (LLNL) conducted a series of important gravity studies using BREN Tower (Kammeraad et al 1990; Kasameyer et al. 1989; Thomas et al. 1989). The purpose was to test Sir Isaac Newton's inverse-square law of gravitational force for intermediate ranges of 10 m to 10 km. Some grand unification theories in physics suggested that Newton's law could break down in the intermediate range. The BREN Tower test of Newton's law involved measuring gravity on the surface of the earth at various distances around the tower, using Pierre Simon Laplace's equation to predict the gravity on the tower, and finally comparing the predictions with actual measurements taken from 12 platforms at different heights on the tower. The BREN Tower was ideal for this investigation because of the tower's height, its location on the NTS, and an extensive gravity database already compiled for the NTS by the United States Geological Survey and the National Oceanographic and Atmospheric Administration. The LLNL researchers made more than 800 measurements during the two phases of this experiment and the subsequent analyses produced results consistent with Newton's law convincingly demonstrating that the inverse-square law of gravitational force held true for intermediate ranges (Johnston 2003:8).

In early 1991, LLNL proposed the Brilliant Pebbles research project that would utilize the tower for a captive flight test (U.S. DOE 1992). The project was in support of former President Reagan's Strategic Defense Initiative whose purpose was to develop a system to shield the United States and allies from a ballistic missile attack. The centerpiece of the Strategic Defense System was space-based, kinetic-kill vehicles. The Brilliant Pebble prototype was a small, maneuverable, rocket-powered vehicle equipped with lasers designed to detect, track, and intercept ballistic missiles. LLNL conducted the tether tests of the prototype vehicle at the earth's surface prior to the more costly space testing program. The experimental plan called for the Brilliant Pebbles prototype to be suspended from BREN Tower at the 1,492 ft (452 m) level using a guy cable and tether. The intent was to simulate the zero gravity of space allowing the vehicle to maneuver freely in the horizontal plane. A series of increasingly complex sequentially-triggered shuttered reflectors would be used to simulate missile tracking and interception for the prototype's laser guidance system. The captive flight experiments were very successful and provided critical data safely, efficiently, and economically (Johnston 2003:8).

Brilliant Pebbles remained an essential component of America's space-based missile defense system even after the dismantling of the Soviet Union in 1991. Although budget cuts effectively shelved the U.S. missile defense program in late 1993, the concept of Brilliant Pebbles-like interceptors was revived as recently as 2004. Data from the Brilliant Pebbles research program continues to inspire current missile defense system research (Independent Working Group 2009).

In response to the planned Brilliant Pebbles experiment, a cultural resource evaluation of the BREN Tower was completed by DRI in December 1991 (Goldenberg and Beck 1991a). The tower was determined eligible to the National Register of Historic Places through consultations between the Department of Energy, Nevada Operations Office and the Nevada State Historic Preservation Office.

Currently the BREN Tower Complex sits abandoned and unused with the exception of the Control Bunker and the active substation. Until recently, the bunker was being used for storage but was emptied in late 2011. NNSS/NSO plans to demolish the BREN Tower in the immediate future because it is no longer structurally sound and has become a safety hazard.

PART IV. SOURCES OF INFORMATION

Auxier, J.A.

- 1964 *Ichiban: the Dosimetry Program for Nuclear Bomb Survivors of Hiroshima and Nagasaki –A Status Report as of April 1, 1964. CEX-64.03 Civil Effects Study, Civil Effects Test Operations, U.S. Atomic Energy Commission, Washington, D.C.*
- 1977 *Ichiban: Radiation Dosimetry for the Survivors of the Bombings of Hiroshima and Nagasaki. Report #TID-27080, National Technical Information Service, Springfield, VA.*
- 2004 Interview by Susan Edwards, Desert Research Institute, 07 June, 2004. Health Physicist with Oak Ridge National Laboratory – Technical Director for Operation BREN and Program Director and Scientific Advisor for Operation HENRE.

Beck, C.M., H. Drollinger, and N. Goldenberg

- 2000 *A Historical Evaluation of the Test Cell A Facility for Characterization Activities Associated with Decontamination and Decommissioning, Area 25, Nevada Test Site, Nye County, Nevada. Cultural Resources Reconnaissance Short Report No. SR021400-1, Desert Research Institute, Las Vegas, NV.*
- 2001 *Nevada Test Site, Test Cell C Facility. Historic American Engineering Record No. NV-33, U.S. National Park Service, Washington, D.C.*

Beck, C.M., N. G. Goldenberg, H. Drollinger, R. Jones, and D. L. Winslow

- 1996 *A Historical Evaluation of the Engine Maintenance Assembly and Disassembly Facility, Area 25, Nevada Test Site, Nye County, Nevada. Cultural Resources Reconnaissance Short Report No. SR082696-1, Desert Research Institute, Las Vegas, NV.*

Beck, C.M., N. Goldenberg, W.G. Johnson, and C. Sellers

- 1996 *Nevada Test Site Historic Structures Survey. Desert Research Institute, Quaternary Sciences Center, Technical Report No. 87, Las Vegas, NV.*

Beck, C.M., N.G. Goldenberg, and D.L. Winslow

- 1995 *A Historical Evaluation of Jr. Hot Cell for Characterization Activities Associated with Decontamination and Decommissioning, Area 25, Nevada Test Site, Nye County, Nevada. Cultural Resources Reconnaissance Short Report No. SR032095-1, Desert Research Institute, Las Vegas, NV.*

Brookings Institute

- 2011 U.S. Nuclear Weapons Cost Study Project, U.S. Nuclear Weapons Research, Development, Testing and Production, and Naval Nuclear Propulsion Facilities. Brookings Institute website <http://www.brookings.edu/projects/archive/nucweapons/sites.aspx>, last accessed 15 December 2011.

Burson, Z.G.

- 1971 Radiation Output Description from the $T(d,n)^4\text{He}$ Reaction in a Large Target (1000 cm^2) – Operation HENRE. USAEC Report *CEX 65.04 Civil Effects Study*, Civil Effects Test Operations, U.S. Atomic Energy Commission, Washington, D.C.

Butler, H.M. and F.F. Haywood

- 1971 Radiation Safety – Operation HENRE, USAEC Report CEX 65.05 Civil Effects Study, Civil Effects Test Operations, U.S. Atomic Energy Commission, Washington D.C.

Cannan, R.K.

- 1964 News Report, National Academy of Sciences, National Research Council, 12 (1).

Cheka, J.S.

- 1969 Distribution of Radiation from a 14 Mev Neutron Source in and Near Structures, USAEC Report *CEX 65.13 Civil Effects Study*, Civil Effects Test Operations, U.S. Atomic Energy Commission, Washington D.C.

Cormier, R.V.

- 1975 The Behavior of Vertically Integrated Boundary-Layer Winds, *Boundary-Layer Meteorology*, Vol. 9(3): 315-324, November 1975.

Cornett, J.S. and K.C. Brundidge

- 1970 A Comparison of the Wind Spectra Calculated from Data Obtained by Independent Sampling Methods, *Monthly Weather Review*, Vol. 98(3): 233-237.

Dohrenwend, J.C.

- 1987 Basin and Range. In *Geomorphic Systems of North America*, edited by W.L. Graf, pp. 303-342. Centennial Special Volume 2, Geological Society of America, Boulder, CO.

Dresser-Ideco Co., Inc.

- 1961a Steel Details for 1520 ft. Guyed Tower, Atomic Energy Commission. Engineering Drawing #19013 41, ARC File # 58157, on file at Archives and Records Center, Mercury, NV.
- 1961b Bottom Outside Steel Details for 1520 ft. Guyed Tower, Atomic Energy Commission. Engineering Drawing #19013 43, ARC File # 58158, on file at Archives and Records Center, Mercury, NV.

- 1961c Steel Details for 1520 ft. Guyed Tower, Atomic Energy Commission. Engineering Drawing #19013 44A, ARC File # 58159, on file at Archives and Records Center, Mercury, NV.
- 1961d Erection Drawing for 1520 ft. Guyed Tower, Atomic Energy Commission. Engineering Drawing #19013 E03, on file at Archives and Records Center, Mercury, NV.
- 1961e Design of Foundation for Stairway for 1520 ft. Guyed Tower, Atomic Energy Commission. Engineering Drawing #19013 SK15, ARC File # 58113, on file at Archives and Records Center, Mercury, NV.
- 1961f Design of Foundation for Winch for 1520 ft. Guyed Tower, Atomic Energy Commission. Engineering Drawing #19013 SK16, ARC File # 58114, on file at Archives and Records Center, Mercury, NV.
- 1961g Erection of Stairs to Hoist Platform for 1520 ft. Guyed Tower, Atomic Energy Commission. Engineering Drawing #19013 E18, on file at Archives and Records Center, Mercury, NV.
- 1961h Hoist Car for 1520 ft. Guyed Tower, Atomic Energy Commission. Engineering Drawing #19013 SK8C, ARC # 58121, on file at Archives and Records Center, Mercury, NV.
- 1961i Assembly Drawing for Covers for Hoist Car for 1520 ft. Guyed Tower, Atomic Energy Commission. Engineering Drawing #19013 A81A, on file at Archives and Records Center, Mercury, NV.
- 1961j Hoist Car Layout and Erection for 1520 ft. Guyed Tower, Atomic Energy Commission. Engineering Drawing #20155 E6A, ARC # 58181, on file at Archives and Records Center, Mercury, NV.
- 1961k Inside Elevator Layout and Erection for 1520 ft. Guyed Tower, Atomic Energy Commission. Engineering Drawing #19013 E15A, on file at Archives and Records Center, Mercury, NV.
- 1965 Tower Base for 1520 ft. Guyed Tower, Atomic Energy Commission. Engineering Drawing #20155 SK4A, ARC File # 58197, on file at Archives and Records Center, Mercury, NV.
- 1966a Center Pier Foundation for 1520 ft. Guyed Tower, Atomic Energy Commission. Engineering Drawing # 20719 F5, ARC File #58218, on file at Archives and Records Center, Mercury, NV.

- 1966b Center Pier Foundation for 1520 ft. Guyed Tower, Atomic Energy Commission. Engineering Drawing # 20719 F4, ARC File # 58217, on file at Archives and Records Center, Mercury, NV.
- 1966c Foundation Orientation for 1520 ft. Guyed Reactor Tower, Atomic Energy Commission. Engineering Drawing # 20719 F1, ARC File # 58214, on file at Archives and Records Center, Mercury, NV.
- 1966d Design for Guy Anchor Foundations for 1520 ft. Guyed Reactor Tower, Atomic Energy Commission. Engineering Drawing # 20719 FD3A, ARC File # 58213, on file at Archives and Records Center, Mercury, NV.
- 1966e Inner Anchors for 1520 ft. Guyed Reactor Tower, Atomic Energy Commission. Engineering Drawing # 20719 F2, ARC File # 58215, on file at Archives and Records Center, Mercury, NV.
- 1966f Outer Anchors for 1520 ft. Guyed Reactor Tower, Atomic Energy Commission. Engineering Drawing # 20719 32, ARC File # 58216, on file at Archives and Records Center, Mercury, NV.

Drollinger, H.

- 2004 *An Historical Evaluation of the Super Kukla Control Building, Building 5430, Area 27, Nevada Test Site, Nye County, Nevada.* Cultural Resources Reconnaissance Short Report No. HE042104-3, Desert Research Institute, Las Vegas, NV.
- 2005 *An Historical Evaluation of the Pluto Control Facility Area 26, Nevada Test Site, Nye County, Nevada.* Cultural Resources Reconnaissance Short Report No. HE041305-1, Desert Research Institute, Las Vegas, NV.

Drollinger, H., C.M. Beck, and R. Furlow

- 2003 *Cultural Resources Management Plan for the Nevada Test Site, Revision 1.* National Technical Information Service, U.S. Department of Commerce, Springfield, VA.

Drollinger, H., C.M. Beck, and N. Goldenberg

- 2000a *Nevada Test Site, Test Cell C Facility, Building 3210.* Historic American Engineering Record No. NV-30, U.S. National Park Service, Washington, D.C.
- 2000b *Nevada Test Site, Super Kukla Facility, Buildings 5400 and 5400A.* Historic American Engineering Record No. NV-31, U.S. National Park Service, Washington, D.C.
- 2000c *Nevada Test Site, Reactor Maintenance and Disassembly Facility, Building 3110.* Historic American Engineering Record No. NV-29, U.S. National Park Service, Washington, D.C.

2000d *Nevada Test Site, Pluto Facility, Disassembly Building 2201*. Historic American Engineering Record No. NV-32, U.S. National Park Service, Washington, D.C.

Drollinger, H., N. Goldenberg, and C.M. Beck

2000a *An Historical Evaluation of Pluto Building 2201, Area 26, Nevada Test Site, Nye County, Nevada*. Cultural Resources Reconnaissance Short Report No. SR102599-1, Desert Research Institute, Las Vegas, NV.

2000b *An Historical Evaluation of Test Cell C Facility for Characterization Activities Associated with Decontamination and Decommissioning, Area 25, Nevada Test Site, Nye County, Nevada*. Cultural Resources Reconnaissance Short Report No. SR021500-1, Desert Research Institute, Las Vegas, NV.

2000c *An Historical Evaluation of the R-MAD Building in Area 25 for Planned Activities Associated with the Environmental Management Decontamination and Decommissioning Program, Nevada Test Site, Nye County, Nevada*. Cultural Resources Reconnaissance Short Report No. SR022900-1, Desert Research Institute, Las Vegas, NV.

2000d *An Historical Evaluation of the Super Kukla Facility in Area 27 for Activities Associated with the Environmental Management Decontamination and Decommissioning Program, Nevada Test Site, Nye County, Nevada*. Cultural Resources Reconnaissance Short Report No. SR021700-1, Desert Research Institute, Las Vegas, NV.

Drollinger, H., C. M. Beck, D. Winslow, and N. Goldenberg

1997 *Nevada Test Site, Engine Maintenance Assembly and Disassembly Facility*. Historic American Engineering Record No. NV-25, U.S. National Park Service, Washington, D.C.

Edwards, S. R.

1997 *Atomic Age Training Camp: The Historical Archaeology of Camp Desert Rock*. M.A. Thesis, Department of Anthropology and Ethnic Studies, University of Nevada, Las Vegas.

Edwards, S.R. and N. Goldenberg

2007 *An Historical Evaluation of the BREN Tower Complex, Area 25, Nevada Test Site, Nye County, Nevada*. Cultural Resources Historical Evaluation Report No. HE110106-1, Desert Research Institute, Las Vegas, NV.

Fehner, T.R. and F.G. Gosling

2002 *Origins of the Nevada Test Site*. U.S. Department of Energy, History Division, Washington, D.C.

Fernald, A.T., G.S. Corchary, and W.P. Williams

- 1968 Surficial Geological Map of Yucca Flat, Nye and Lincoln Counties, Nevada. U.S.G.S. Miscellaneous Geological Investigations Map I-550.

French, R.L. and L.G. Mooney

- 1971 Differential Measurements of Fast-Neutron Air-Ground Interface Effects, Project 9.2 – Operation HENRE, USAEC Report *CEX 65.92 Civil Effects Study*, Civil Effects Test Operations, U.S. Atomic Energy Commission, Washington, D.C.

Goldenberg, N.G. and C.M. Beck

- 1991a *Historic Structure Inventory and Evaluation: BREN Tower, Area 25, Nevada Test Site, Nye County, Nevada*. Cultural Resources Reconnaissance Short Report No. SR092791-1, Desert Research Institute, Las Vegas, NV.

- 1991b *Historic Building Inventory and Evaluation: Underground Parking Garage, Nevada Test Site, Nye County, Nevada*. Cultural Resources Reconnaissance Short Report No. SR092691-1, Desert Research Institute, Las Vegas, NV.

Haywood, F.F.

- 2004 Interview by Susan Edwards, Desert Research Institute, 07 June, 2004. Health Physicist for Oak Ridge National Laboratory - Radiological Safety Officer for Operation BREN and Technical Director for Operation HENRE.

Haywood, F.F. and J.A. Auxier

- 1965 Technical Concept – Operation HENRE, *CEX 65.02 Civil Effects Study*, Civil Effects Test Operations, U.S. Atomic Energy Commission, Washington, D.C.

Hollingsworth, R.E.

- 1966 Letter with Encls. (“Nevada Test Site Road Map” showing location of HENRE Tower and “Description of Operation HENRE Programs”) from R. E. Hollingsworth, U.S. Atomic Energy Commission, to Honorable Chet Holifield, July 21. On file at: Nuclear Testing Archive, National Nuclear Security Administration, Nevada Site Office, Las Vegas, NV, Accession No. NV0177150.

Holmes & Narver, Inc.

- 1962 CETO - Operation BREN, Collimator Turret Base, Plan & Section, Engineering Drawing # JS-004-403-S1.2, on file at Archives and Records Center, Mercury, NV.

- 1965a Foxhole Covers & Cable Troughs - Sta. T28a, Detail, Plan & Sections, Engineering Drawing # JS-028-T28a-S6.2, on file at Archives and Records Center, Mercury, NV.

- 1965b Project HENRE, Turntable Leveling Screws - Sta. T28a, Plan, Section, & Details, Engineering Drawing # JS-028-T28a-S8.2, on file at Archives and Records Center, Mercury, NV.
- 1966a BREN Tower Area –Sta. T28a, Partial Plan, Engineering Drawing # JS-028-T28a-C2.6, on file at Archives and Records Center, Mercury, NV.
- 1966b BREN Tower, Control Bunker –Sta. 300, Plan, Sections & Details, Engineering Drawing # 028-300-S1, on file at Archives and Records Center, Mercury, NV.
- 1966c BREN Tower, Control Bunker –Sta. 300, Elevations, Sections & Details, Engineering Drawing # 028-300-S2, ARC File # 37062, on file at Archives and Records Center, Mercury, NV.
- 1966d Sta. – T28a, Quonset Hut Electrical Floor Plan & Details, Engineering Drawing # JS-028-T28a-E18, on file at Archives and Records Center, Mercury, NV.
- 1966e Project HENRE, Program #1 Pipe Shelter- Sta. T28a, Electrical & Mechanical Plan & Details, Engineering Drawing # JS-028-T28a-E7.1-M3-1, on file at Archives and Records Center, Mercury, NV.
- 1966f Operation HENRE, Program #1 Pipe Shelter- Sta. T28a, Plan Sections & Details, Engineering Drawing # JS-028-T28a-S10, on file at Archives and Records Center, Mercury, NV.
- 1966g Collimators and Inserts - Sta. T28a, Modification Details, Engineering Drawing # JS-028-T28a-S7.1, on file at Archives and Records Center, Mercury, NV.
- 1966h BREN Tower – Sta. T28a, Site Plan, Engineering Drawing # JS-028-T28a-C1.8, on file at Archives and Records Center, Mercury, NV.
- 1966i Wood Frame Struct. – Type “A” – Sta. T28a, Section & Elevations, Engineering Drawing # JS-028-T28a-S12, on file at Archives and Records Center, Mercury, NV.
- 1966j Wood Frame Struct. – Type “A” – Sta. T28a, Plan & Schedules, Engineering Drawing # JS-028-T28a-S11, on file at Archives and Records Center, Mercury, NV.
- 1966k Trailer Revetments - Sta. T28a, Plan & Section, Engineering Drawing # JS-028-T28a-C6.1, on file at Archives and Records Center, Mercury, NV.
- 1966l Phantom Platform - Sta. T28a, Plan, Elevation & Details, Engineering Drawing # JS-028-T28a-S3.2, on file at Archives and Records Center, Mercury, NV.

- 1966m Phantom Platform – Sta. T28a, Details, Engineering Drawing # JS-028-T28a-S4.1, on file at Archives and Records Center, Mercury, NV.
- 1966n Program #3 Trolley System - Sta. T28a, Schematic, Engineering Drawing # JS-028-T28a-S9, on file at Archives and Records Center, Mercury, NV.
- 1966o Programs 3 & 5 Fox Holes – Sta. T28a, Excavation Details, Engineering Drawing # JS-028-T28a-C3.4, on file at Archives and Records Center, Mercury, NV.
- 1966p Project HENRE, Winch Facility - Sta. T28a, Plan, Elevation & Details, Engineering Drawing # JS-028-T28a-M1.5-S1.5, on file at Archives and Records Center, Mercury, NV.
- 1966q Trailer Revetment - Sta. T28a, Plan, Sections & View, Engineering Drawing # JS-028-T28a-S2.3, on file at Archives and Records Center, Mercury, NV.
- 1966r Project HENRE, Trailer Park Site Plan- Sta. T28a, Civil Plan & Mech. Details, Engineering Drawing # JS-028-T28a-C7.2-M4.2, on file at Archives and Records Center, Mercury, NV.
- 1966s Project HENRE, Trailer Park Site Plan- Sta. T28a, Electrical Plan & Details, Engineering Drawing # JS-028-T28a-E8.2, on file at Archives and Records Center, Mercury, NV.
- 1967 Modifications to Surface Facilities - Sta. T28a, Details & Equipment List, Engineering Drawing # JS-028-T28a-E10.1, on file at Archives and Records Center, Mercury, NV.
- 1969 ESSA - Sta. T28a, 88 Ft. Tower, Electrical Plan, Engineering Drawing # JS-028-T28a-E17.2, on file at Archives and Records Center, Mercury, NV.
- 1970a NASA Sonic Boom Program, BREN Tower – Microphone Array, Schematic & Details, Engineering Drawing # JS-028-086-C1, on file at Archives and Records Center, Mercury, NV.
- 1970b NASA Sonic Boom Flight Test Program,– Microphone Supp'ts on BREN Tower, Engineering Drawing # 028-086, on file at Archives and Records Center, Mercury, NV.

Independent Working Group

- 2009 *Missile Defense, the Space Relationship, and the Twenty-First Century: Brilliant Pebbles.* Electronic document, MissileThreat.com website, http://www.missilethreat.com/missiledefensesystems/id.13/system_detail.asp, accessed 15 December .2011.

Johnson, W.G.

- 1994 *A Historical Evaluation of the Area 2 Equipment Support Yard, Yucca Flat, Area 2, Nevada Test Site, Nye County, Nevada.* Cultural Resources Reconnaissance Short Report No. SR020894-1, Desert Research Institute, Las Vegas, NV.
- 2002 *A Historical Evaluation of the T-3b Fizeau Bunker, Area 3, Nevada Test Site, Nye County, Nevada.* Cultural Resources Reconnaissance Short Report No. SR082201-1, Desert Research Institute, Las Vegas, NV.

Johnson, W.G. and S.R. Edwards

- 1996 *Historic American Building Survey Documentation of the Japanese Village on the Nevada Test Site.* Historic American Building Survey No. NV-27, U.S. National Park Service, Washington, D.C.
- 2000 *Survival Town: The Apple-2 Historic District, Nevada Test Site, Nye County, Nevada.* Cultural Resources Reconnaissance Technical Report No. 99, Division of Earth and Ecosystem Sciences, Desert Research Institute, Las Vegas, NV.

Johnson, W.G. and N. Goldenberg

- 1998 *Historic American Building Survey Documentation of the Environmental Protection Agency Farm on the Nevada Test Site.* Historic American Building Survey No. NV-28, U.S. National Park Service, Washington, D.C.

Johnson, W.G., B. Holz, and R.C. Jones

- 2000 *A Cold War Battlefield: Frenchman Flat Historic District, Nevada Test Site, Nye County, Nevada.* Cultural Resources Technical Report No. 97, Division of Earth and Ecosystem Sciences, Desert Research Institute, Las Vegas, NV.

Johnston, D.

- 2003 "Deserted Tower Seeks New Lease on Life," *Newsline*, Friday, March 28, 2003, Vol. 28(12), pp. 1,8, Lawrence Livermore National Laboratory, University of California, Livermore.

Jones, R.C. and N. Goldenberg

- 2004 *A Historical Evaluation of Station 7-800 in Area 7, Nevada Test Site, Nye County, Nevada.* Cultural Resources Reconnaissance Short Report No. HE042004-1, Desert Research Institute, Las Vegas, NV.

Jones, R.C. and H. Drollinger

- 2001 *A Class III Cultural Resources Reconnaissance of the Proposed Underground Test Area Seismic Lines in Frenchman Flat, Nevada Test Site, Areas 5 and 11, and Nellis Air Force Range, Nye County, Nevada.* Cultural Resources Reconnaissance Short Report No. SR060401-1, Desert Research Institute, Las Vegas, NV.

Jones, R.C., C.M. Beck, and B.A. Holz

- 2005 *Inventory of Structures for the Yucca Lake Historic District, Area 6, Nevada Test Site, Nye County, Nevada*. Cultural Resources Technical Report No.102, Desert Research Institute, Las Vegas, NV.

Jones, R.C., C.M. Beck, A. DuBarton, S.R. Edwards, N. Goldenberg, and J. Carroll

- 1996 *A Class III Cultural Resources Reconnaissance of the Proposed Reentry Body Impact Fuze Flights (RBIFF), Area 26, Nevada Test Site, Nye County, Nevada*. Cultural Resources Reconnaissance Short Report No. SR121395-2, Desert Research Institute, Las Vegas, NV.

Jorgensen, C.D. and C.L. Hayward

- 1965 *Mammals of the Nevada Test Site*. Brigham Young University Scientific Bulletin, Biological Series 6(3):1-81.

Kammeraad, J., P. Kasameyer, O.Fackler, D. Felske, R. Harris, M. Millet, M. Mugge, and J. Thomas

- 1990 Results from Nevada: A Test of Newton's Law Using the BREN Tower and a High Density Ground Gravity Survey. Moriond Workshop on New and Exotic Phenomena, Les Arcs, Savoie, France, Report No. UCRL-JC-103562, Lawrence Livermore National Laboratory, Livermore, CA.

Kane, E.J.

- 1973 Review of Current Sonic Boom Studies, *Journal of Aircraft* Vol. 10(7) pp. 395-399.

Kasameyer, P., J. Thomas, O. Fackler, M. Mugee, J. Kammeraad, M. Millet, R. Harris, and D. Felske

- 1989 Tests of Fundamental Laws in Physics, *Proceedings of the XXIVth Rencontre de Moriond*, p.529, O. Fackler and J. Tran Thanh Van, eds. Editions Frontieres, Savoie, France.

Maag, C., S. Rohrer, and R. Shepanek

- 1982 *Operation Ranger: Shots Able, Baker, Easy, Baker-2, Fox, 25 January-6 February 1951*. Defense Nuclear Agency, Washington, D.C.

Medica, P.A.

- 1990 Noteworthy Mammal Distribution Records for the Nevada Test Site. *Great Basin Naturalist* 50(1):83-84.

Nevada Test Site

- 1976 The BREN Tower, unpublished manuscript, 11 November, 1976, Mercury, NV. On file at: Nuclear Testing Archive, National Nuclear Security Administration, Nevada Site Office, Las Vegas, NV, Accession No. NV0132393.

O'Farrell, T.P. and L.A. Emery

1976 *Ecology of the Nevada Test Site: A Narrative Summary and Annotated Bibliography*. U.S. Energy Research and Development Administration, Technical Information Service, Springfield, VA.

Ostler, W. Kent, Dennis J. Hansen, David C. Anderson, and Derek B. Hall

2000 *Classification of Vegetation on the Nevada Test Site*. Report DOE/NV/11718-477, U.S. Department of Energy, Nevada Operations Office, Las Vegas, NV.

Provenzano, T.G., E.J. Story, F.F. Haywood, F.F. and H.T. Miller

1966 Feasibility Study: Intense 14-Mev Neutron Source for Operation HENRE, USAEC Report *CEX 65.01 Civil Effects Study*, Civil Effects Test Operations, U.S. Atomic Energy Commission, Washington, D.C.

Reeves, J.E.

1966 Telex from J.E. Reeves, Manager, Nevada Operations Office, U.S. Atomic Energy Commission, to Addressees, Subject: Proposed Relocation BREN Tower, February 14. On file at: Nuclear Testing Archive, National Nuclear Security Administration, Nevada Site Office, Las Vegas, NV, Accession No. NV0306604.

Rexroad, R.E. and J.R. Jacobson

1973 Experimental Studies of the Neutron and Gamma Shielding Provided by Field Fortifications from a 14-Mev Neutron Source, BRL Report No. 1681, USA Ballistic Research Laboratories, Aberdeen Proving Ground, MD.

Reynolds Electrical & Engineering Co, Inc. (REECo)

1966a "BREN A-Go-Go from Yucca to Jackass: 1527-foot Moving Spectacle," *NTS News*, Vol. IX No. 14, June 10, pp. 6-7, Nevada Test Site, Mercury, NV. On file at NNSA/NSO Nuclear Testing Archive, Las Vegas, NV, Accession No. NV0112363.

1966b "O. HENRE Puts BREN Tower Back in Business," *NTS News*, Vol. IX No. 19, September 16, p. 8, Nevada Test Site, Mercury, NV. On file at NNSA/NSO Nuclear Testing Archive, Las Vegas, NV, Accession No. NV0112369.

1970 "Sonic Booms Studied at BREN," *NTS News*, Vol. IX No. 19, September 4, pp. 6-8, Nevada Test Site, Mercury, NV. On file at NNSA/NSO Nuclear Testing Archive, Las Vegas, NV, Accession No. NV0112054.

1971 "BREN Tower Research," *NTS News and Bulletin Board*, Vol. I No. 13, August 6, p. 2, Nevada Test Site, Mercury, NV. On file at NNSA/NSO Nuclear Testing Archive, Las Vegas, NV, Accession No. NV0111997.

Rhodes, R.

1986 *The Making of the Atomic Bomb*. Simon & Schuster, New York, NY.

1995 *Dark Sun: the Making of the Hydrogen Bomb*. Simon & Schuster, New York, NY.

Sanna, R.S., J.E. McLaughlin, A. Lazanoff, and K. O'Brien

1969 Neutron Spectrometry – Operation HENRE (Program 6), USAEC Report *CEX 65.60 Civil Effects Study*, Civil Effects Test Operations, U.S. Atomic Energy Commission, Washington, D.C.

Schwartz, S.I. (editor)

1998 *Atomic Audit: The Costs and Consequences of U.S. Nuclear Weapons since 1940*. Brookings Institute Press, Washington, DC.

Tajima, E. and R.F. Christy

1986 Preface. In *U.S. – Japan Joint Reassessment of Atomic Bomb Radiation Dosimetry in Hiroshima and Nagasaki* (Volume 2), edited by W.C. Roesch, no page numbers. Radiation Effect Research Foundation, Hiroshima, Japan.

Technical Director's Staff

1965 Operation Plan – Operation HENRE, USAEC Report *CEX 65.03 Civil Effects Study*, Civil Effects Test Operations, U.S. Atomic Energy Commission, Washington, D.C.

Thomas, J., P. Kasameyer, O. Fackler, D. Felske, R. Harris, J. Kammeraad, M. Millet, and M. Mugee

1989 *Physics Review Letter*. 63:1902.

Thorngate, J.H., D.R. Johnson, and P.T. Perdue

1969 Energy and Angular Distribution of Neutrons and Gamma Rays – Operation HENRE, USAEC Report *CEX 65-11 Civil Effects Study*, Civil Effects Test Operations, U.S. Atomic Energy Commission, Washington D.C.

Titus, A.C.

1986 *Bombs in the Backyard: Atomic Testing and American Politics*. University of Nevada Press, Reno.

Tlachac, E.

1991a Nuclear Testing. In *Nevada Comprehensive Preservation Plan*, edited by W.G. White, R.M. James, and R. Bernstein, pp. 25/1-25/12. Division of Historic Preservation and Archaeology, Department of Conservation and Natural Resources, Nevada Historical Society, Department of Museums and History, Carson City, NV.

- 1991b Operating Plan. In *Nevada Comprehensive Preservation Plan*, edited by W.G. White, R.M. James, and R. Bernstein, pp. 25/13-25/24. Division of Historic Preservation and Archaeology, Department of Conservation and Natural Resources, Nevada Historical Society, Department of Museums and History, Carson City, NV.

U.S. Atomic Energy Commission (AEC)

- 1962 "Fact Sheet on Operation BREN," Press Release, 21 March 1962, p. 2, Nevada Operations Office, Las Vegas.
- 1970a "NASA Completes Sonic Boom Research," Press Release, September 01, 1970. Nevada Operations Office, on file at NNSA/NSO Nuclear Testing Archive, Las Vegas, NV, Accession No. NV0325761.
- 1970b "Second Series of Sonic Boom Research Flights Completed," Press Release, November 02, 1970. Nevada Operations Office, on file at NNSA/NSO Nuclear Testing Archive, Las Vegas, NV, Accession No. NV0325733.
- 1970c "Stanford Research Institute has Begun a Laser Research Project at BREN Tower," Press Release, September 21, 1970 Nevada Operations Office, on file at NNSA/NSO Nuclear Testing Archive, Las Vegas, NV, Accession No. NV0325757.
- 1971 "Stanford Research Institute Begins a Laser Research Project at BREN Tower," Press Release, July 19, 1971. Nevada Operations Office, on file at NNSA/NSO Nuclear Testing Archive, Las Vegas, NV, Accession No. NV0325981.

U.S. Department of Energy (DOE)

- 1992 *Environmental Assessment for the Brilliant Pebbles Tether Test at the Nevada Test Site*. April 1992, DOE/EA-0621, Department of Energy, Defense Programs, Washington, D.C.

U.S. Department of the Interior, National Park Service (NPS)

- 1991 *National Register Bulletin 15*. National Park Service Interagency Resources Division, Washington D.C.

White, William G., Ronald M. James, and Richard Bernstein (editors)

- 1991 *Nevada Comprehensive Preservation Plan*. Division of Historic Preservation and Archaeology, Department of Conservation and Natural Resources, Nevada Historical Society, Department of Museums and History, Carson City, NV.

PART V. PROJECT INFORMATION

This manuscript has been prepared at the request of the U.S. Department of Energy, National Nuclear Security Administration, Nevada Field Office in response to the management of cultural resources on the Nevada National Security Site. It is based on a previous investigation conducted by the Desert Research Institute, reported in Cultural Resources Reconnaissance Short Report No. HE110106-1, *Historical Evaluation of the BREN Tower Complex in Area 25, Nevada Test Site, Nye County, Nevada*. Project Manager and Co-Principal Investigator for documentation of the facility was Colleen M. Beck of the Desert Research Institute, Las Vegas, Nevada; Susan R. Edwards of the Desert Research Institute, Las Vegas was the second Principal Investigator; Nancy Goldenberg of Carey & Company, Inc. Architects, San Francisco, California was the Architectural Historian. The photographers were Nancie Nickels of NSTec, Las Vegas, Nevada (large format black-and-white photography), and Colleen Beck, Susan Edwards, Barbara Holz and Robert Jones of the Desert Research Institute, Las Vegas, Nevada (35 mm black-and white and color photography).

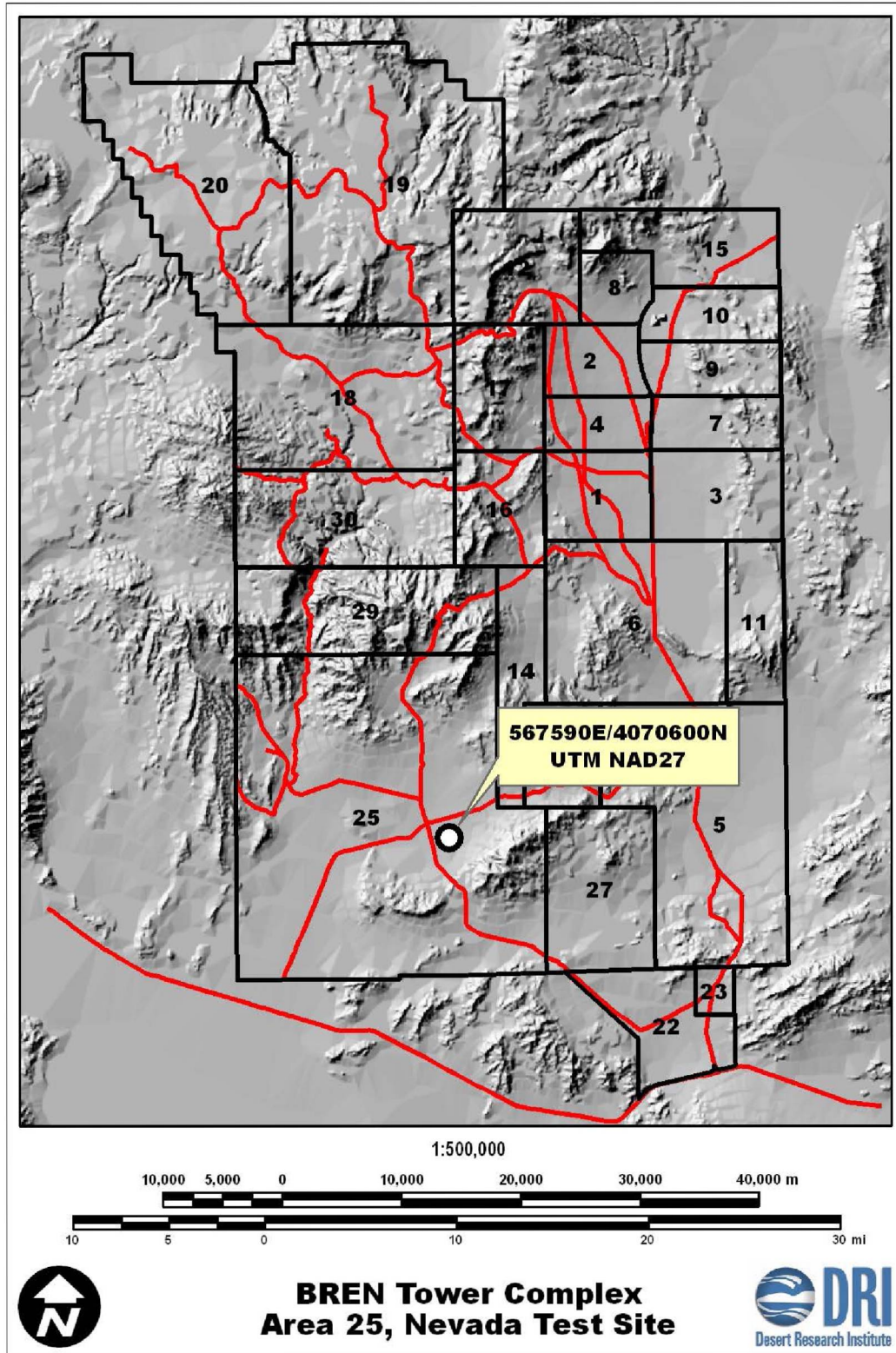

Map 1. Location of BREN Tower Complex on the Nevada Test Site.

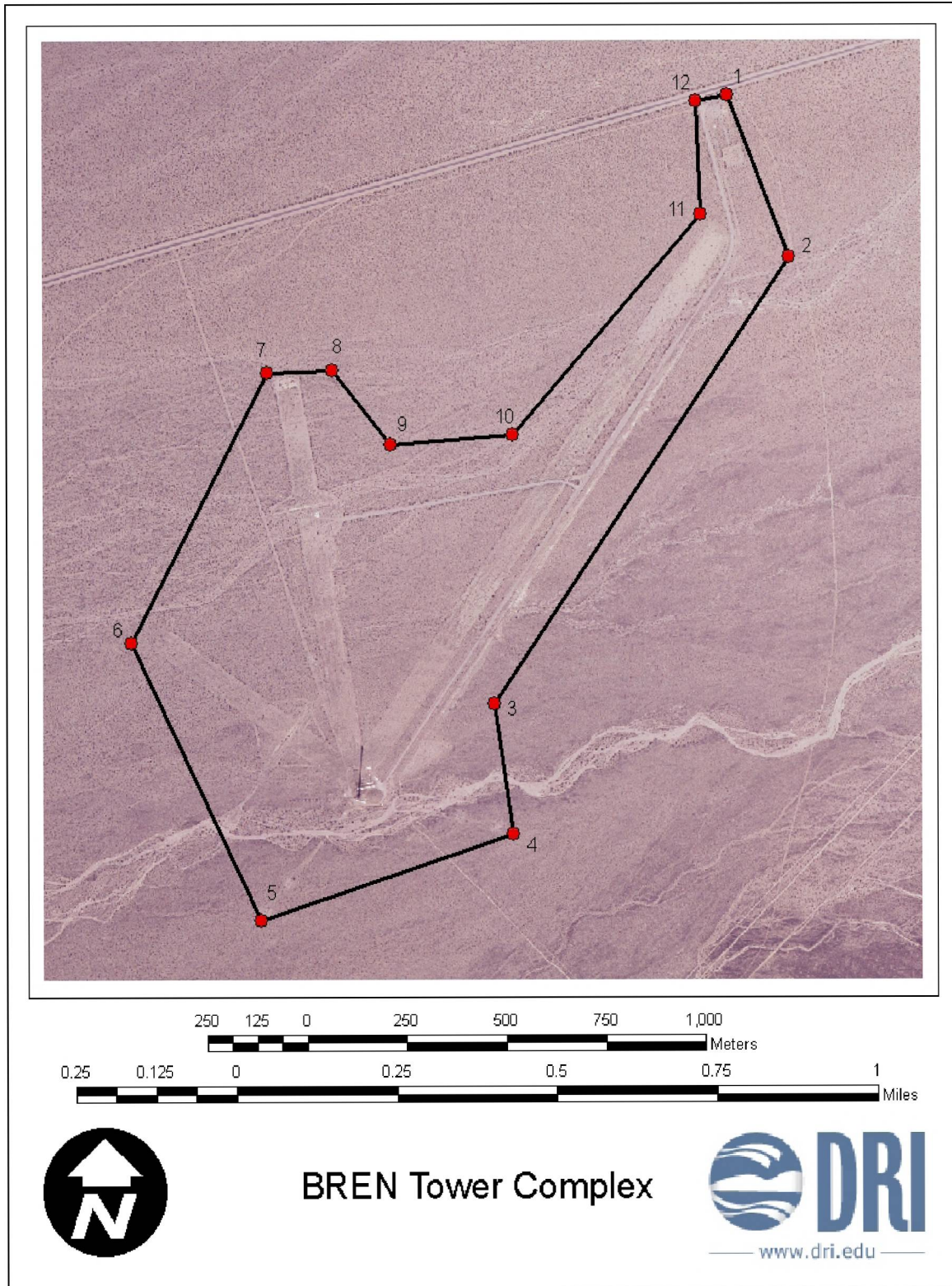

Map 2. Map showing the BREN Tower Complex boundary in black. Numbered red points correspond to UTM locations given on Page 1 of HAER Report.

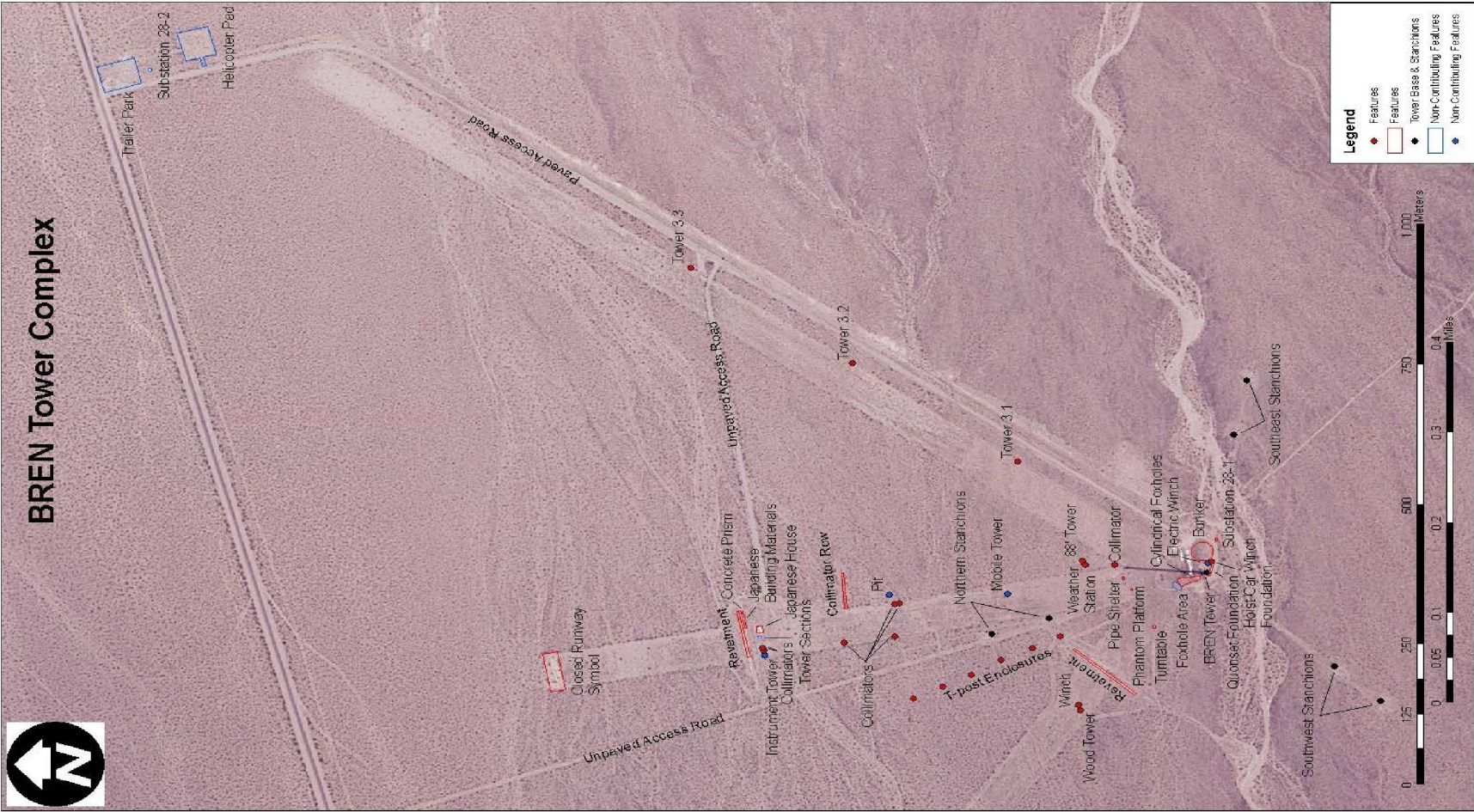

Map 3. Index map of the individual components of the BREN Tower Complex. Contributing properties in red and non-contributing properties in blue.

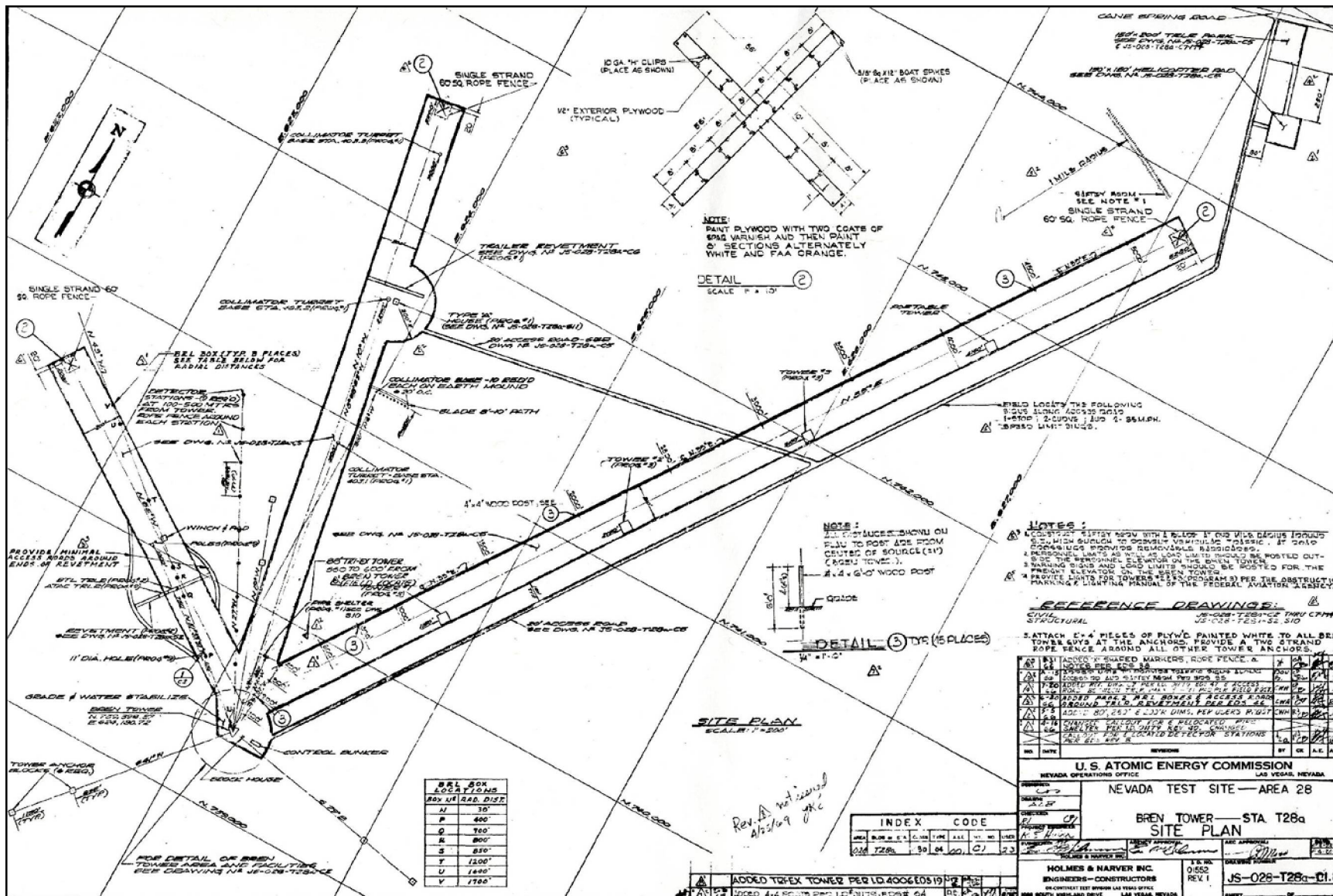

Map 4. 1966 site plan for the BREN Tower Operation HENRE experiment program in NTS Area 25 (aka. Area 28) (Holmes & Narver 1966h).

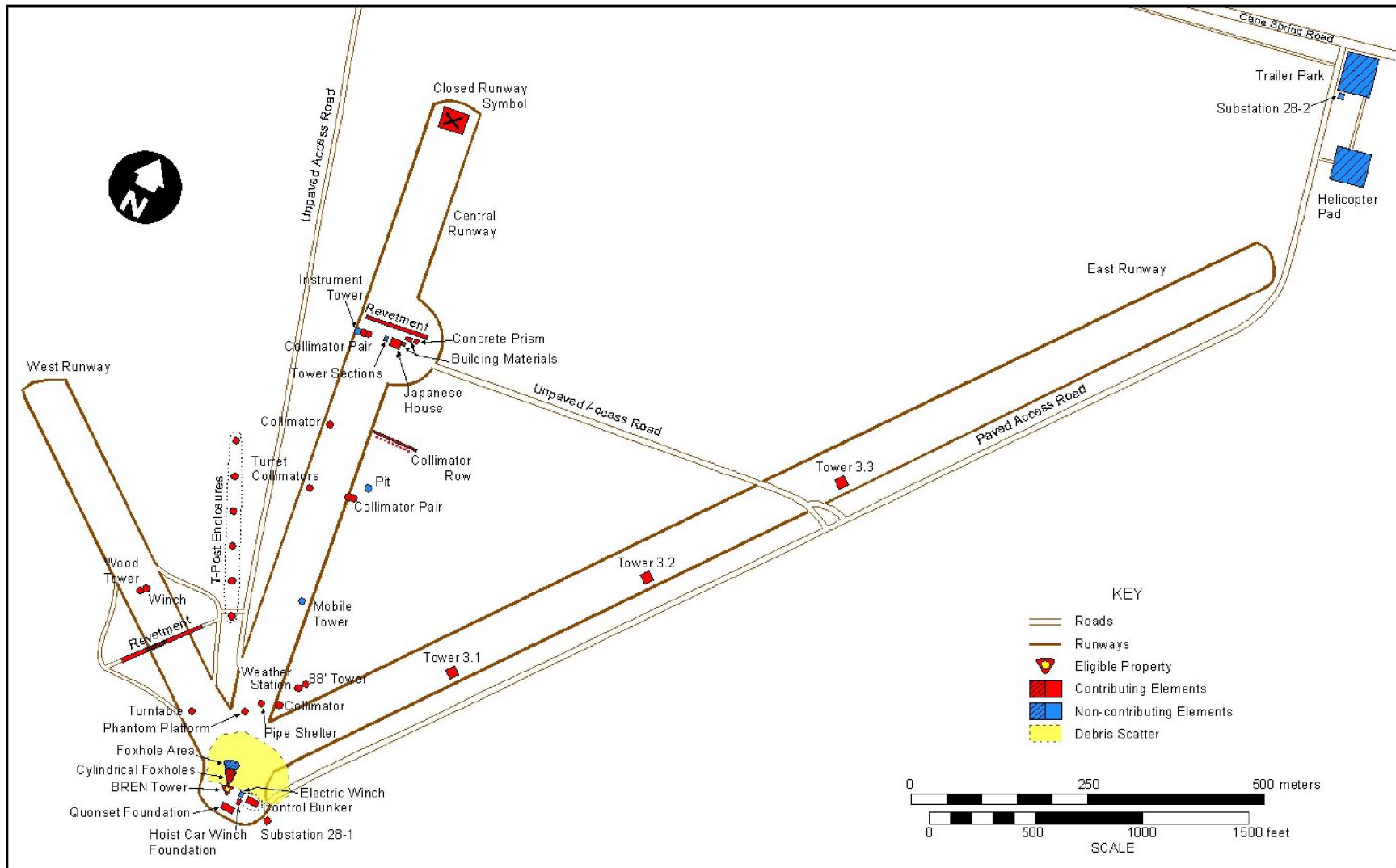

Map 5. Plan view of the BREN Tower Complex including the BREN Tower, primary and remote support facilities, and the Operation HENRE experiment areas (November 2006).

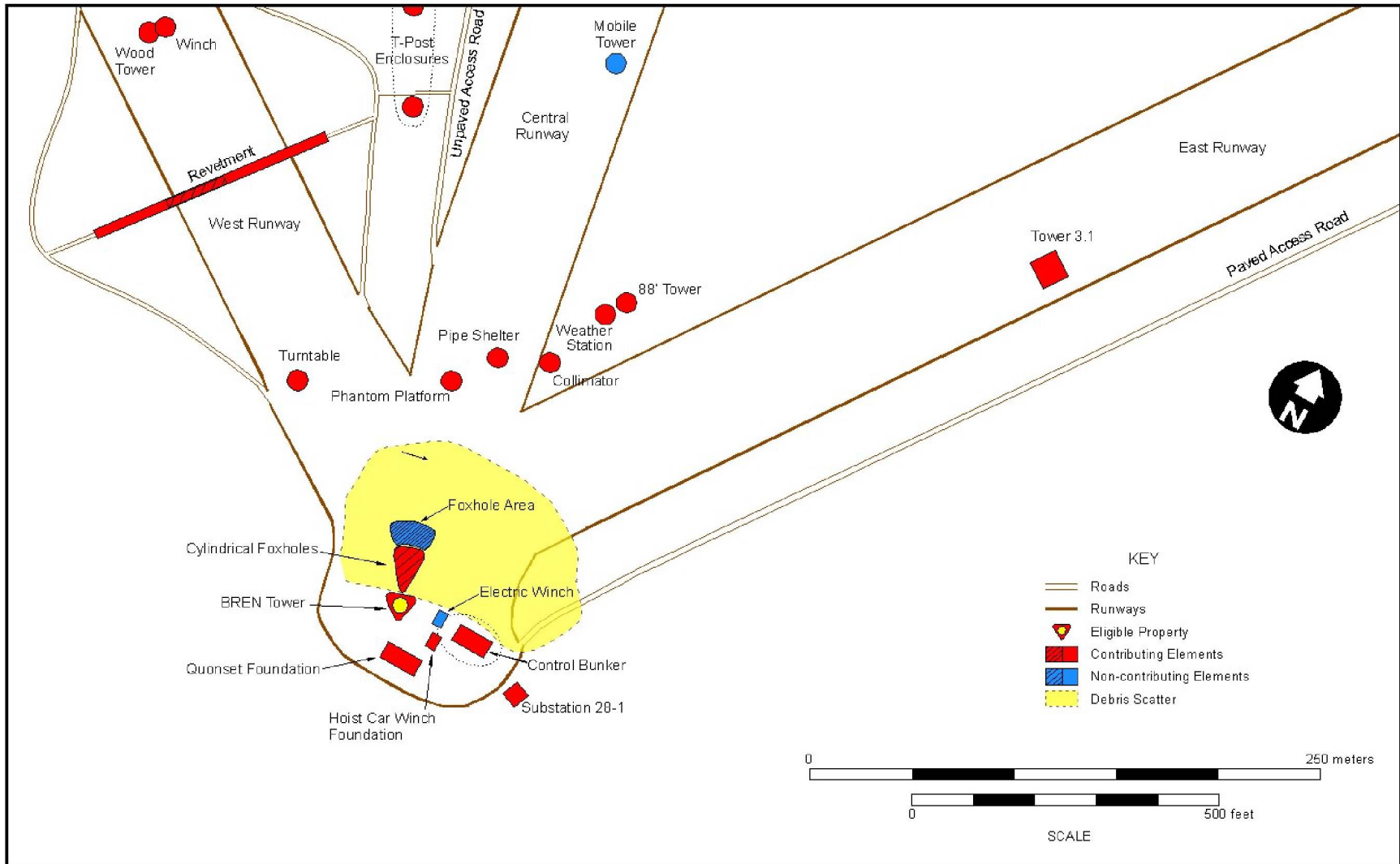

Map 6. Detailed plan view of the BREN Tower Area (November 2006).

HISTORIC AMERICAN ENGINEERING RECORD

INDEX OF PHOTOGRAPHS

HAER NO. NV-47

Nevada Test Site, BREN Tower Complex
(Nevada National Security Site)
Jackass Flats, Area 25
Mercury Vicinity
Nye County
Nevada

NANCIE NICKELS, PHOTOGRAPHER, MARCH 08-16, 2012

- NV-47-01 BREN TOWER OVERVIEW TAKEN FROM BASE OF PROGRAM 9 WOOD TOWER. VIEW TO SOUTHEAST. DATE TAKEN: 14 MAR 2012.
- NV-47-02 OVERVIEW OF CENTER/NORTH "RUNWAY" AND STRUCTURES TAKEN FROM THE 31 FT WORKING PLATFORM ON BREN TOWER. VIEW TO NORTH. DATE TAKEN: 12 MAR 2012.
- NV-47-03 OVERVIEW OF NORTHEAST "RUNWAY" AND STRUCTURES TAKEN FROM THE 31 FT WORKING PLATFORM ON BREN TOWER. VIEW TO NORTHEAST. DATE TAKEN: 12 MAR 2012.
- NV-47-04 OVERVIEW OF EXPERIMENTAL PROGRAM 9 STRUCTURES ALONG NORTHWEST "RUNWAY" TAKEN FROM THE 31 FT WORKING PLATFORM ON BREN TOWER. VIEW TO NORTHWEST. DATE TAKEN: 12 MAR 2012.
- NV-47-05 CLOSED RUNWAY PLYWOOD "X" ON NORTH RUNWAY. VIEW TO SOUTH-SOUTHEAST. DATE TAKEN: 14 MAR 2012.
- NV-47-06 OVERVIEW OF BREN TOWER. VIEW TO NORTH-NORTHEAST. DATE TAKEN: 08 MAR 2012.
- NV-47-07 LOWER PORTION OF BREN TOWER. VIEW TO NORTH-NORTHWEST. DATE TAKEN: 08 MAR 2012.
- NV-47-08 UPPER PORTION OF BREN TOWER. VIEW TO NORTH-NORTHWEST. DATE TAKEN: 08 MAR 2012.
- NV-47-09 BREN TOWER BASE WITH SCALE. VIEW TO NORTHEAST. DATE TAKEN: 08 MAR 2012.

- NV-47-10 BREN TOWER BASE WITHOUT SCALE. VIEW TO NORTHEAST. DATE TAKEN: 08 MAR 2012.
- NV-47-11 BREN TOWER BASE, LOWER 10 SECTIONS. VIEW TO NORTH-NORTHWEST. DATE TAKEN: 15 MAR 2012.
- NV-47-12 BREN TOWER BASE, UPPER SECTIONS FROM WORKING PLATFORM TO TOP. VIEW TO NNW (WP 138) DATE TAKEN: 15 MAR 2012.
- NV-47-13 BREN TOWER. VIEW TO NORTH-NORTHEAST. DATE TAKEN: 15 MAR 2012.
- NV-47-14 BREN TOWER WORKING PLATFORM. VIEW TO NORTH-NORTHWEST. DATE TAKEN: 08 MAR 2012.
- NV-47-15 BREN TOWER PERSONNEL ELEVATOR. VIEW TO NORTHEAST. DATE TAKEN: 08 MAR 2012.
- NV-47-16 STAIRWAY TO BREN TOWER WORKING PLATFORM. VIEW TO NORTH-NORTHEAST. DATE TAKEN: 08 MAR 2012.
- NV-47-17 STAIRWAY TO BREN TOWER WORKING PLATFORM. VIEW TO EAST-NORTHEAST. DATE TAKEN: 08 MAR 2012.
- NV-47-18 DETAIL OF BREN TOWER CONTROL PANEL ON EAST ELEVATION. VIEW TO WEST. DATE TAKEN: 12 MAR 2012.
- NV-47-19 OVERVIEW OF BREN TOWER'S SOUTHWEST STANCHIONS SHOWING BOTH SETS. VIEW TO THE SOUTHWEST. DATE TAKEN: 08 MAR 2012.
- NV-47-20 NORTHERNMOST PAIR OF BREN TOWER'S SOUTHWEST STANCHIONS. VIEW TO THE SOUTHWEST. DATE TAKEN: 08 MAR 2012.
- NV-47-21 SOUTHERNMOST PAIR OF BREN TOWER'S SOUTHWEST STANCHIONS. VIEW TO THE WEST-SOUTHWEST. DATE TAKEN: 08 MAR 2012.
- NV-47-22 NORTHERN PAIR OF BREN TOWER'S NORTH STANCHIONS. VIEW TO NORTH. DATE TAKEN: 13 MAR 2012.

- NV-47-23 OVERVIEW OF BREN TOWER'S NORTH STANCHIONS SHOWING BOTH SETS. VIEW TO THE NORTH-NORTHEAST. DATE TAKEN: 13 MAR 2012.
- NV-47-24 SOUTHERN PAIR OF BREN TOWER'S NORTH STANCHIONS. VIEW TO NORTH-NORTHWEST. DATE TAKEN: 13 MAR 2012.
- NV-47-25 OVERVIEW OF BREN TOWER'S SOUTHEAST STANCHIONS SHOWING BOTH SETS. VIEW TO THE EAST-SOUTHEAST. DATE TAKEN: 15 MAR 2012.
- NV-47-26 DETAIL OF NORTHWESTERN PAIR OF BREN TOWER'S SOUTHWEST STANCHIONS. VIEW TO THE EAST. DATE TAKEN: 15 MAR 2012.
- NV-47-27 DETAIL OF SOUTHWESTERN PAIR OF BREN TOWER'S SOUTHWEST STANCHIONS. VIEW TO THE NORTHEAST. DATE TAKEN: 15 MAR 2012.
- NV-47-28 PAIRED TOWER FROM BRILLIANT PEBBLES EXPERIMENT. VIEW TO WEST-NORTHWEST. DATE TAKEN: 12 MAR 2012.
- NV-47-29 BRILLIANT PEBBLES EXPERIMENT INSTRUMENTATION STAND. VIEW TO NORTHWEST. DATE TAKEN: 08 MAR 2012.
- NV-47-30 NET FENCE. VIEW TO NORTH-NORTHEAST. DATE TAKEN: 13 MAR 2012.
- NV-47-31 CONTROL BUNKER ENTRANCE AND MOUND WITH BREN TOWER IN BACKGROUND. VIEW TO NORTHWEST. DATE TAKEN: 12 MAR 2012.
- NV-47-32 CONTROL BUNKER, ENTRANCE. VIEW TO THE NORTH. DATE TAKEN: 16 MAR 2012.
- NV-47-33 CONTROL BUNKER, ENTRANCE DOOR CLOSED. VIEW TO THE WEST. DATE TAKEN: 16 MAR 2012.
- NV-47-34 CONTROL BUNKER, ENTRANCE DOOR OPEN SHOWING INTERIOR HALLWAY. VIEW TO THE WEST. DATE TAKEN: 16 MAR 2012.
- NV-47-35 CONTROL BUNKER, INTERIOR OF ROOM 5 SHOWING CORNER BATHROOM. VIEW TO THE SOUTHEAST. DATE TAKEN: 16 MAR 2012.

- NV-47-36 CONTROL BUNKER, INTERIOR OF ROOM 4 FROM DOORWAY. VIEW TO THE NORTHWEST. DATE TAKEN: 16 MAR 2012.
- NV-47-37 CONTROL BUNKER, INTERIOR OF ROOM 3 FROM DOORWAY. VIEW TO THE NORTHWEST. DATE TAKEN: 16 MAR 2012.
- NV-47-38 CONTROL BUNKER, INTERIOR OF ROOM 2 FROM DOORWAY. VIEW TO THE NORTHWEST. DATE TAKEN: 16 MAR 2012.
- NV-47-39 CONTROL BUNKER, INTERIOR OF ROOM 1 FROM SOUTHWEST CORNER. VIEWING WINDOW BETWEEN ROOMS 1 AND 2 IS IN WEST WALL. VIEW TO THE NORTHEAST. DATE TAKEN: 16 MAR 2012.
- NV-47-40 CONTROL BUNKER, INTERIOR OF ROOM 1 FROM SOUTH WALL. CEILING-MOUNTED MONITOR PLATFORM VISIBLE AT THE TOP LEFT. VIEW TO THE NORTH. DATE TAKEN: 16 MAR 2012.
- NV-47-41 CONTROL BUNKER, INTERIOR HALLWAY. VIEW TO NORTHEAST TOWARDS EXTERIOR ENTRANCE DOOR. DOORWAYS INTO ROOMS 2-5 VISIBLE ON NORTH SIDE OF HALL. DATE TAKEN: 16 MAR 2012.
- NV-47-42 CONTROL BUNKER, INTERIOR OF ROOM 4 EAST WALL "GRAFFITI". VIEW TO THE EAST. DATE TAKEN: 16 MAR 2012.
- NV-47-43 QUONSET HUT CONCRETE PAD WITH SCALE. VIEW TO NORTHEAST. DATE TAKEN: 08 MAR 2012.
- NV-47-44 QUONSET HUT CONCRETE PAD WITHOUT SCALE. VIEW TO WEST-SOUTHWEST. DATE TAKEN: 08 MAR 2012.
- NV-47-45 CONCRETE AND WOOD WINCH PAD AT BASE OF THE CONTROL BUNKER MOUND. VIEW TO EAST. DATE TAKEN: 08 MAR 2012.
- NV-47-46 ELECTRIC WINCH FROM BRILLIANT PEBBLES EXPERIMENTS. VIEW TO EAST-NORTHEAST. DATE TAKEN: 08 MAR 2012.
- NV-47-47 SUBSTATION 28-1, OBLIQUE VIEW OF SOUTH AND EAST ELEVATIONS. CONTROL BUNKER MOUND AND BREN TOWER IN BACKGROUND. VIEW TO WEST-NORTHWEST. DATE TAKEN: 12 MAR 2012.
- NV-47-48 CULVERT PIPE SHELTER. OVERVIEW OF ENTRANCE DOOR, VENTILATION PIPE AND EXPOSED SHELTER ROOF. VIEW TO NORTHWEST. DATE TAKEN: 13 MAR 2012.

- NV-47-49 OVERVIEW OF CULVERT PIPE SHELTER AND CABLE RUN. VIEW TO NORTH-NORTHWEST. DATE TAKEN: 12 MAR 2012.
- NV-47-50 CULVERT PIPE SHELTER, ENTRANCE DOOR DETAIL. VIEW TO WEST. DATE TAKEN: 12 MAR 2012.
- NV-47-51 COLLIMATOR AT 450 FT FROM BREN TOWER. OBLIQUE VIEW OF REAR AND SOUTHWEST SIDE. VIEW TO NORTHEAST. DATE TAKEN: 12 MAR 2012.
- NV-47-52 COLLIMATOR AT 450 FT FROM BREN TOWER. OBLIQUE VIEW OF FRONT AND NORTHEAST SIDE. VIEW TO NORTHWEST. DATE TAKEN: 12 MAR 2012.
- NV-47-53 MOBILE WEATHER STATION. VIEW TO NORTHEAST. DATE TAKEN: 12 MAR 2012.
- NV-47-54 MOBILE TOWER. VIEW TO WEST. DATE TAKEN: 14 MAR 2012.
- NV-47-55 TURRET-MOUNTED COLLIMATORS AT 1,500 FT FROM BREN TOWER, FRONT VIEW. VIEW TO NORTH-NORTHWEST. DATE TAKEN: 13 MAR 2012.
- NV-47-56 TURRET-MOUNTED COLLIMATORS AT 1,500 FT FROM BREN TOWER, OBLIQUE VIEW OF REAR AND NORTHWEST SIDE. VIEW TO SOUTHEAST. DATE TAKEN: 13 MAR 2012.
- NV-47-57 COLLIMATORS AT 1,520 FT FROM BREN TOWER. OBLIQUE VIEW OF BOTH PAIR AND INTERIOR PLUG. VIEW TO NORTHEAST. DATE TAKEN: 13 MAR 2012.
- NV-47-58 COLLIMATORS AT 1,520 FT FROM BREN TOWER. FRONT OF WESTERNMOST MEMBER OF PAIR. VIEW TO NORTH-NORTHEAST. DATE TAKEN: 13 MAR 2012.
- NV-47-59 COLLIMATORS AT 1,520 FT FROM BREN TOWER. FRONT OF EASTERNMOST MEMBER OF PAIR. VIEW TO NORTH-NORTHEAST. DATE TAKEN: 13 MAR 2012.
- NV-47-60 COLLIMATOR AT 1,800 FT FROM BREN TOWER. OBLIQUE VIEW TO NORTHEAST SHOWING FRONT SIDE AND REAR VENT PIPE. DATE TAKEN: 13 MAR 2012.
- NV-47-61 COLLIMATOR ROW AT 1,800 FT FROM BREN TOWER, FRONT VIEW. VIEW TO NORTH. DATE TAKEN: 13 MAR 2012.

- NV-47-62 COLLIMATOR ROW AT 1,800 FT FROM BREN TOWER, BACK VIEW. VIEW TO SOUTHEAST. DATE TAKEN: 13 MAR 2012.
- NV-47-63 METAL TOWER THAT REPLACED TURRET-MOUNTED COLLIMATORS AT 2,250 FT FROM BREN TOWER. VIEW TO NORTHWEST. DATE TAKEN: 14 MAR 2012.
- NV-47-64 PAIR OF PLATFORM MOUNTED COLLIMATORS AT 2,250 FT FROM BREN TOWER. VIEW TO NORTHWEST. DATE TAKEN: 14 MAR 2012.
- NV-47-65 JAPANESE HOUSE EXTERIOR, SOUTH ELEVATION WITHOUT SCALE. VIEW TO NORTH. DATE TAKEN: 14 MAR 2012.
- NV-47-66 JAPANESE HOUSE EXTERIOR, SOUTH ELEVATION WITH SCALE. VIEW TO NORTH. DATE TAKEN: 14 MAR 2012.
- NV-47-67 JAPANESE HOUSE EXTERIOR, WEST AND SOUTH ELEVATIONS. OBLIQUE VIEW TO NORTH-NORTHEAST. DATE TAKEN: 14 MAR 2012.
- NV-47-68 JAPANESE HOUSE EXTERIOR, WEST ELEVATION. VIEW TO EAST-NORTHEAST. DATE TAKEN: 14 MAR 2012.
- NV-47-69 JAPANESE HOUSE EXTERIOR, NORTH ELEVATION. VIEW TO SOUTH. DATE TAKEN: 14 MAR 2012.
- NV-47-70 JAPANESE HOUSE EXTERIOR, NORTH AND EAST ELEVATIONS. OBLIQUE VIEW TO SOUTHWEST. DATE TAKEN: 14 MAR 2012.
- NV-47-71 JAPANESE HOUSE EXTERIOR, EAST ELEVATION. VIEW TO WEST. DATE TAKEN: 14 MAR 2012.
- NV-47-72 JAPANESE HOUSE, INTERIOR. DETAIL OF RAFTERS. VIEW TO THE NORTHWEST. DATE TAKEN: 16 MAR 2012.
- NV-47-73 JAPANESE HOUSE, INTERIOR. SOUTH WALL. VIEW TO THE SOUTHEAST. DATE TAKEN: 16 MAR 2012.
- NV-47-74 JAPANESE HOUSE, INTERIOR. EAST WALL. VIEW TO THE EAST. DATE TAKEN: 16 MAR 2012.
- NV-47-75 JAPANESE HOUSE, INTERIOR. NORTH WALL. OBLIQUE VIEW TO THE NORTH-NORTHEAST. DATE TAKEN: 16 MAR 2012.

- NV-47-76 JAPANESE HOUSE, INTERIOR. NORTH WALL. VIEW TO THE NORTH. DATE TAKEN: 16 MAR 2012.
- NV-47-77 CONCRETE PRISM INSIDE THE JAPANESE HOUSE. VIEW TO THE WEST-NORTHWEST. DATE TAKEN: 16 MAR 2012.
- NV-47-78 CONCRETE PRISM BEHIND JAPANESE HOUSE, VIEW TO THE NORTH-NORTHEAST. DATE TAKEN: 14 MAR 2012.
- NV-47-79 JAPANESE HOUSE AND BELOW GRADE TRAILER REVETMENT VIEW TO THE SOUTHWEST. DATE TAKEN: 15 MAR 2012.
- NV-47-80 CRATES OF IMPORTED BUILDING MATERIALS BEHIND JAPANESE HOUSE. VIEW TO THE EAST-NORTHEAST. DATE TAKEN: 14 MAR 2012.
- NV-47-81 DETAIL OF BUILDING MATERIAL CRATES SHOWING “MADE IN JAPAN” LABEL. VIEW TO THE NORTH-NORTHWEST. DATE TAKEN: 14 MAR 2012.
- NV-47-82 DISMANTLED METAL TOWER SECTIONS BY JAPANESE HOUSE. VIEW TO THE NORTH-NORTHWEST. DATE TAKEN: 14 MAR 2012
- NV-47-83 ELECTRICAL SUB-CIRCUIT ENCLOSURE NO. 28-1 4160 2 1 VOLTAGE CIRCUIT ENCLOSURE. VIEW TO NORTHWEST. DATE TAKEN: 14 MAR 2012.
- NV-47-84 ELECTRICAL SUB-CIRCUIT ENCLOSURE NO. 28-1 4160 2 1 TO THE WEST OF THE JAPANESE HOUSE. OBLIQUE VIEW TO THE EAST-SOUTHEAST. DATE TAKEN: 15 MAR 2012.
- NV-47-85 ELECTRICAL SUB-CIRCUIT ENCLOSURE NO. 28-1 4160 2 1 TO THE WEST OF THE JAPANESE HOUSE. OBLIQUE VIEW TO THE EAST-SOUTHEAST. DATE TAKEN: 15 MAR 2012.
- NV-47-86 PHANTOM PLATFORM, VIEW TO THE NORTHWEST. DATE TAKEN: 12 MAR 2012.
- NV-47-87 OVERVIEW OF BREN TOWER AND TOWERS 3.1, 3.2, AND 3.3. EXPERIMENTAL PROGRAM 3 SET OF THREE 150 FT HIGH METAL TOWERS LOCATED BETWEEN 1,150 FT AND 3,150 FT TO THE EAST OF BREN TOWER. BREN TOWER IS TALLER STRUCTURE TO THE LEFT. VIEW TO THE SOUTH-SOUTHWEST. DATE TAKEN: 15 MAR 2012.

- NV-47-88 TOWER 3.1. EXPERIMENTAL PROGRAM 3,150 FT HIGH METAL TOWER 1,150 FT TO THE EAST OF BREN TOWER. TOWERS 3.2 AND 3.3 VISIBLE IN BACKGROUND. VIEW TO THE NORTHEAST. DATE TAKEN: 15 MAR 2012.
- NV-47-89 TOWER 3.1. EXPERIMENTAL PROGRAM 3,150 FT HIGH METAL TOWER 1,150 FT TO THE EAST OF BREN TOWER. DETAIL OF TOWER BASE AND PLACARD. VIEW TO THE NORTH-NORTHEAST. DATE TAKEN: 15 MAR 2012.
- NV-47-90 TOWER 3.1. EXPERIMENTAL PROGRAM 3,150 FT HIGH METAL TOWER 1,150 FT TO THE EAST OF BREN TOWER. DETAIL OF TOWER GUY WIRE ANCHOR. VIEW TO THE NORTH-NORTHWEST. DATE TAKEN: 15 MAR 2012.
- NV-47-91 TOWER 3.2. EXPERIMENTAL PROGRAM 3,150 FT HIGH METAL TOWER 2,150 FT TO THE EAST OF BREN TOWER. VIEW TO THE NORTH-NORTHEAST. DATE TAKEN: 15 MAR 2012.
- NV-47-92 TOWER 3.2. EXPERIMENTAL PROGRAM 3,150 FT HIGH METAL TOWER 2,150 FT TO THE EAST OF BREN TOWER. DETAIL OF CABLE REEL, PLACARD, AND BROKEN PULLEY ASSEMBLY. VIEW TO THE NORTHEAST. DATE TAKEN: 15 MAR 2012.
- NV-47-93 TOWER 3.3. EXPERIMENTAL PROGRAM 3,150 FT HIGH METAL TOWER 3,150 FT TO THE EAST OF BREN TOWER. VIEW TO THE NORTH-NORTHEAST. DATE TAKEN: 15 MAR 2012.
- NV-47-94 TOWER 3.3. EXPERIMENTAL PROGRAM 3,150 FT HIGH METAL TOWER 3,150 FT TO THE EAST OF BREN TOWER. DETAIL OF CABLE REEL, PLACARD, AND BROKEN PULLEY ASSEMBLY. VIEW TO THE NORTH. DATE TAKEN: 15 MAR 2012.
- NV-47-95 EIGHTY-EIGHT FT. TOWER. VIEW TO THE SOUTHEAST. DATE TAKEN: 12 MAR 2012.
- NV-47-96 OVERVIEW OF EXPERIMENTAL PROGRAM 5 CYLINDRICAL FOXHOLE COVERS MADE OF CONCRETE AND METAL. VIEW TO THE SOUTHWEST. DATE TAKEN: 12 MAR 2012.
- NV-47-97 OVERVIEW OF CYLINDRICAL FOXHOLE AT BASE OF BREN TOWER. VIEW TO THE WEST. DATE TAKEN: 12 MAR 2012.
- NV-47-98 OVERVIEW OF MIDDLE ARC OF THREE CYLINDRICAL FOXHOLES. VIEW TO THE SOUTH. DATE TAKEN: 12 MAR 2012.

- NV-47-99 OVERVIEW OF THIRD ARC OF THREE CYLINDRICAL FOXHOLES. VIEW TO THE EAST. DATE TAKEN: 12 MAR 2012.
- NV-47-100 T-POLE INSTRUMENT STATIONS. VIEW TO THE NORTH-NORTHEAST. DATE TAKEN: 13 MAR 2012.
- NV-47-101 PROGRAM 9, TURNTABLE. VIEW TO THE NORTH. DATE TAKEN: 13 MAR 2012.
- NV-47-102 PROGRAM 9, TURNTABLE STAND. VIEW TO THE SOUTH-SOUTHEAST. DATE TAKEN: 13 MAR 2012.
- NV-47-103 PROGRAM 9, DETAIL OF TURNTABLE MARKINGS. VIEW DOWN AND TO THE SOUTHEAST. DATE TAKEN: 13 MAR 2012.
- NV-47-104 PROGRAM 9 TWIN-POLE WOODEN TOWER. VIEW TO THE WEST. DATE TAKEN: 13 MAR 2012.
- NV-47-105 PROGRAM 9 ELECTRIC WINCH AND CONTROL PANEL, VIEW TO THE SOUTHEAST. DATE TAKEN: 13 MAR 2012.
- NV-47-106 PROGRAM 9 BELOW GRADE REINFORCED TRAILER REVETMENT, OVERVIEW. VIEW TO SSW (WP 097) DATE TAKEN: 13 MAR 2012.
- NV-47-107 PROGRAM 9 BELOW GRADE REINFORCED TRAILER REVETMENT, DETAIL OF STRUCTURE TAKEN FROM SE EMBANKMENT. VIEW TO THE WEST. DATE TAKEN: 13 MAR 2012.
- NV-47-108 PROGRAM 9 BELOW GRADE TRAILER REVETMENT. DETAIL OF WEST END OF REVETMENT GARAGE. VIEW TO THE NORTH-NORTHEAST. DATE TAKEN: 13 MAR 2012.
- NV-47-109 BREN TOWER COMPLEX'S MAIN ENTRANCE GATE WITH BROKEN BARRICADE ARM. SUBSTATION 28-2 AND GRADED SUPPORT TRAILER PADS VISIBLE IN BACKGROUND. VIEW TO THE SOUTHEAST. DATE TAKEN: 15 MAR 2012.
- NV-47-110 BREN TOWER COMPLEX'S MAIN ENTRANCE GATE. DETAIL OF BROKEN BARRICADE ARM. VIEW TO THE SOUTHEAST. DATE TAKEN: 15 MAR 2012.
- NV-47-111 SUBSTATION 28-2 WITH BLADED TRAILER PADS VISIBLE TO THE RIGHT AND LEFT OF THE SUBSTATION. VIEW TO THE NORTH-NORTHEAST. DATE TAKEN: 15 MAR 2012.

HISTORIC AMERICAN ENGINEERING RECORD
SEE INDEX TO PHOTOGRAPHS FOR CAPTION

HAER No. NV-47-1



HISTORIC AMERICAN ENGINEERING RECORD
SEE INDEX TO PHOTOGRAPHS FOR CAPTION

HAER No. NY-47-2



HISTORIC AMERICAN ENGINEERING RECORD
SEE INDEX TO PHOTOGRAPHS FOR CAPTION

HAER No. NV-47-3



HISTORIC AMERICAN ENGINEERING RECORD
SEE INDEX TO PHOTOGRAPHS FOR CAPTION

HAER No. NV-47-4



HISTORIC AMERICAN ENGINEERING RECORD
SEE INDEX TO PHOTOGRAPHS FOR CAPTION

HAER No. NV-47-5



HISTORIC AMERICAN ENGINEERING RECORD
SEE INDEX TO PHOTOGRAPHS FOR CAPTION

HAER No. NV-47-6



HISTORIC AMERICAN ENGINEERING RECORD
SEE INDEX TO PHOTOGRAPHS FOR CAPTION

HAER No. NV-47-7



HISTORIC AMERICAN ENGINEERING RECORD
SEE INDEX TO PHOTOGRAPHS FOR CAPTION

HAER No. NV-47-8



HISTORIC AMERICAN ENGINEERING RECORD
SEE INDEX TO PHOTOGRAPHS FOR CAPTION

HAER No. NV-47-9



HISTORIC AMERICAN ENGINEERING RECORD
SEE INDEX TO PHOTOGRAPHS FOR CAPTION

HAER No. *NV-47-10*



HISTORIC AMERICAN ENGINEERING RECORD
SEE INDEX TO PHOTOGRAPHS FOR CAPTION

HAER No. NV-47-11



HISTORIC AMERICAN ENGINEERING RECORD
SEE INDEX TO PHOTOGRAPHS FOR CAPTION

HAER No. NV-47-12



HISTORIC AMERICAN ENGINEERING RECORD
SEE INDEX TO PHOTOGRAPHS FOR CAPTION

HAER No. NV-47-13



HISTORIC AMERICAN ENGINEERING RECORD
SEE INDEX TO PHOTOGRAPHS FOR CAPTION

HAER No. NV-47-14



HISTORIC AMERICAN ENGINEERING RECORD
SEE INDEX TO PHOTOGRAPHS FOR CAPTION

HAER No. NV-47-15



HISTORIC AMERICAN ENGINEERING RECORD
SEE INDEX TO PHOTOGRAPHS FOR CAPTION

HAER No. NY-47-16



HISTORIC AMERICAN ENGINEERING RECORD
SEE INDEX TO PHOTOGRAPHS FOR CAPTION

HAER No. NV-47-17



HISTORIC AMERICAN ENGINEERING RECORD
SEE INDEX TO PHOTOGRAPHS FOR CAPTION

HAER No. NV-47-18

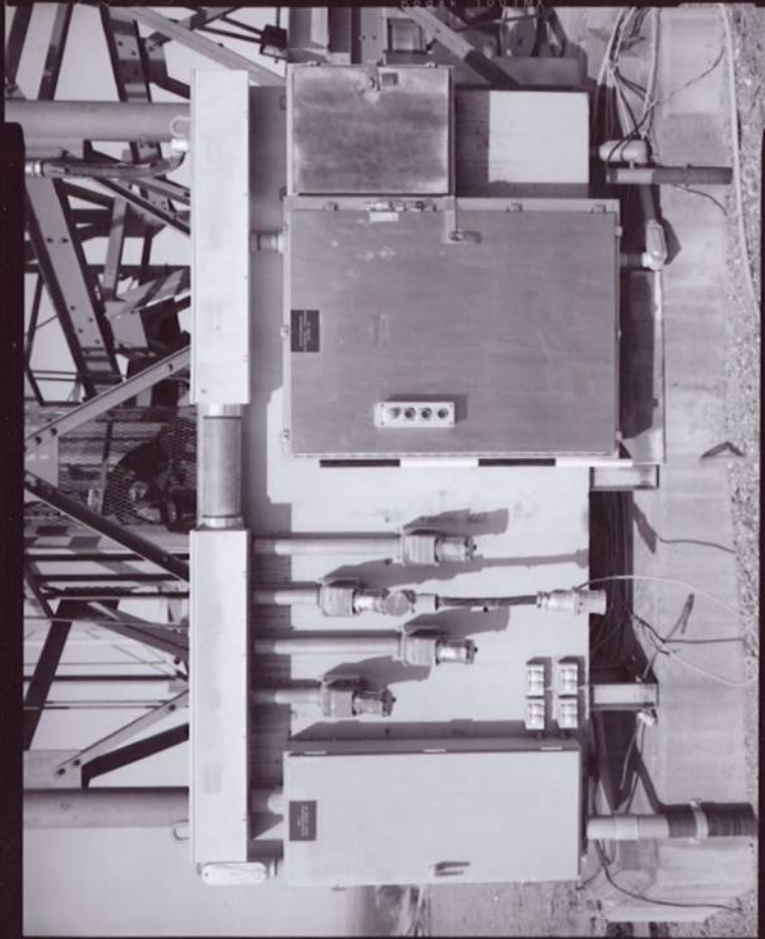

HISTORIC AMERICAN ENGINEERING RECORD
SEE INDEX TO PHOTOGRAPHS FOR CAPTION

HAER No. NV-47-19



HISTORIC AMERICAN ENGINEERING RECORD
SEE INDEX TO PHOTOGRAPHS FOR CAPTION

HAER No. NV-47-20



HISTORIC AMERICAN ENGINEERING RECORD
SEE INDEX TO PHOTOGRAPHS FOR CAPTION

HAER No. NY-47-21

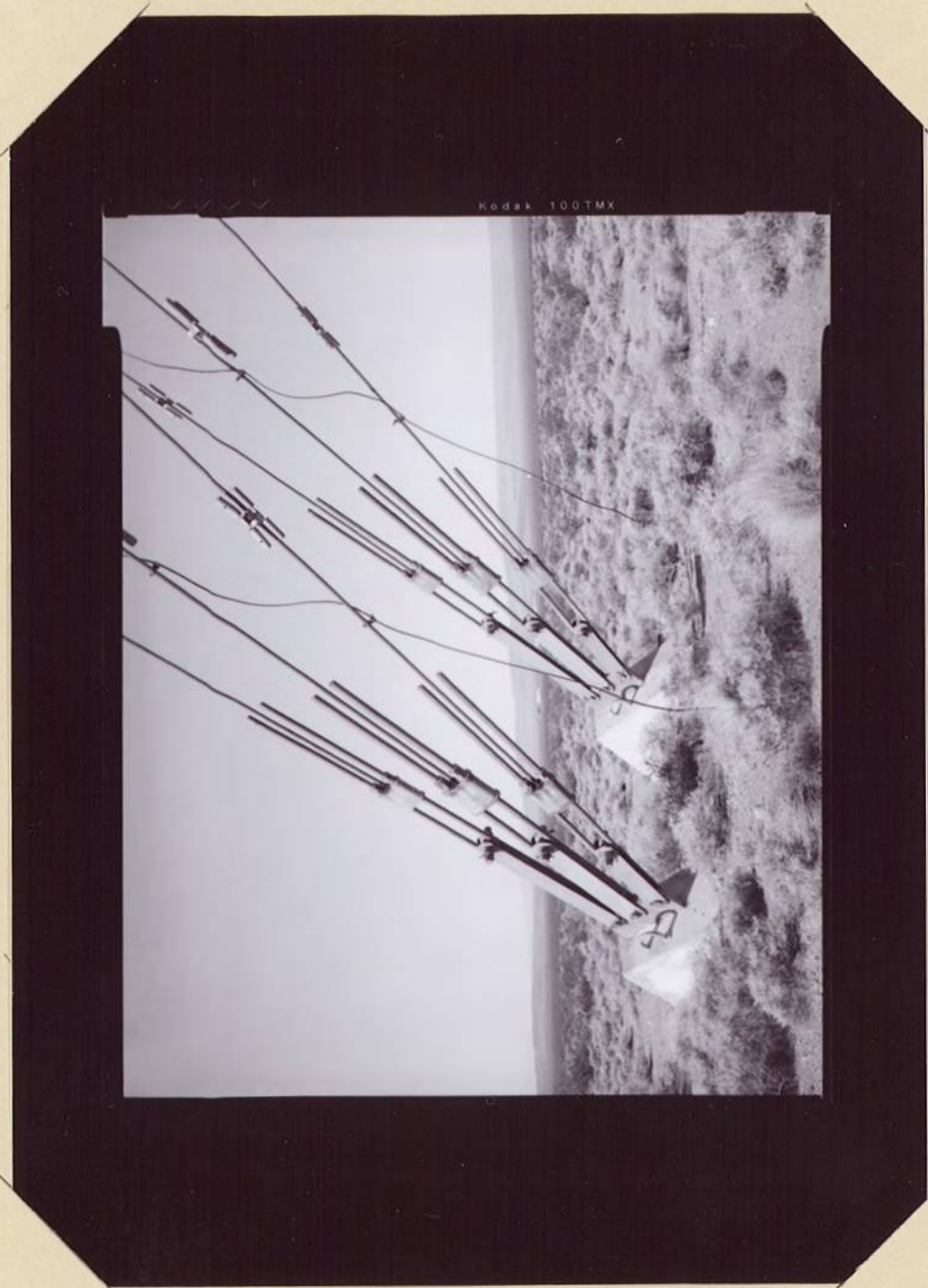

HISTORIC AMERICAN ENGINEERING RECORD
SEE INDEX TO PHOTOGRAPHS FOR CAPTION

HAER No. NV-47-22



HISTORIC AMERICAN ENGINEERING RECORD
SEE INDEX TO PHOTOGRAPHS FOR CAPTION

HAER No. NV-47-23



HISTORIC AMERICAN ENGINEERING RECORD
SEE INDEX TO PHOTOGRAPHS FOR CAPTION

HAER No. NV-47-24



HISTORIC AMERICAN ENGINEERING RECORD
SEE INDEX TO PHOTOGRAPHS FOR CAPTION

HAER No. NV-47-25



HISTORIC AMERICAN ENGINEERING RECORD
SEE INDEX TO PHOTOGRAPHS FOR CAPTION

HAER No. NV-47-26



HISTORIC AMERICAN ENGINEERING RECORD
SEE INDEX TO PHOTOGRAPHS FOR CAPTION

HAER No. NV-47-27

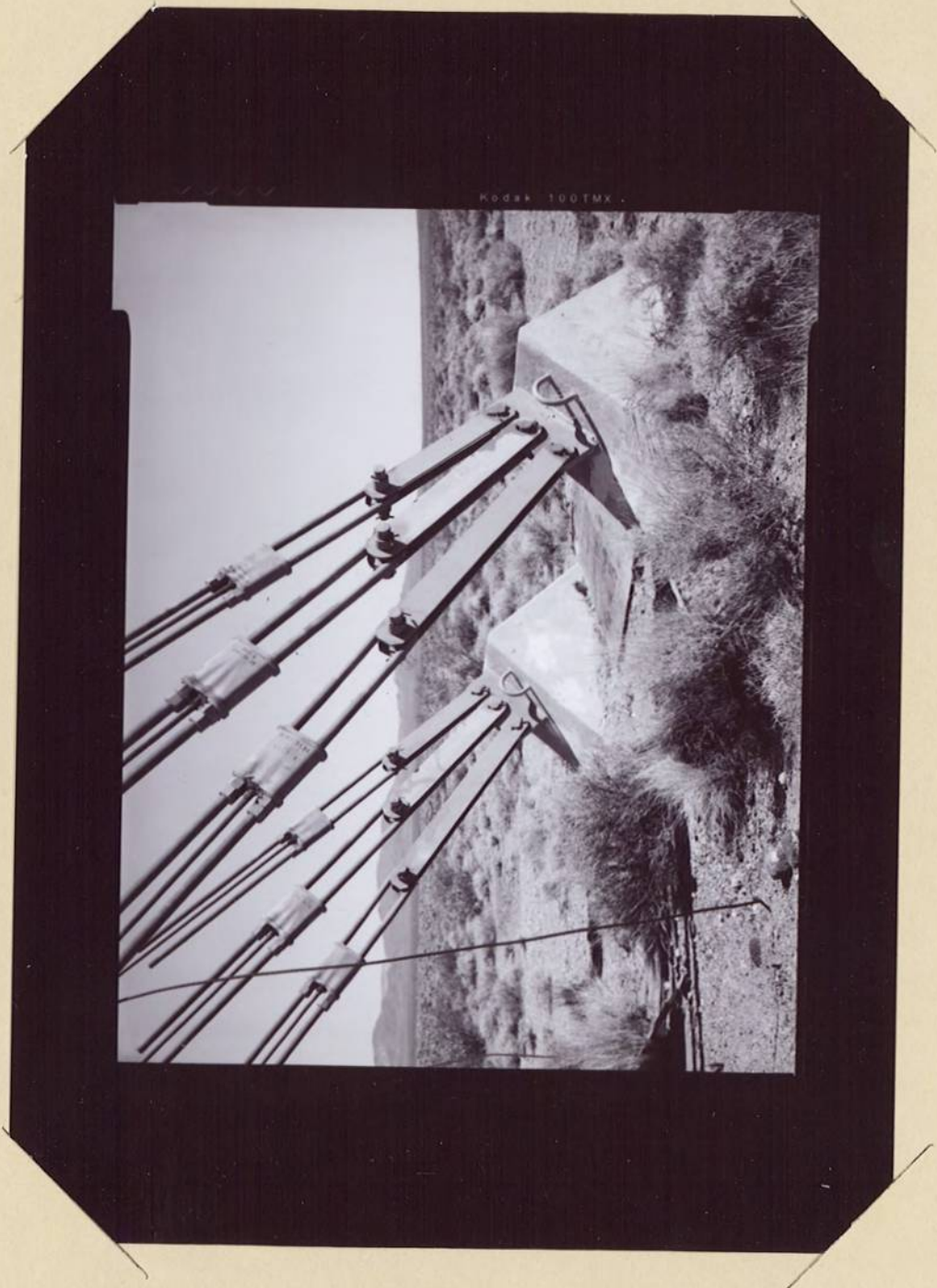

HISTORIC AMERICAN ENGINEERING RECORD
SEE INDEX TO PHOTOGRAPHS FOR CAPTION

HAER No. NV-47-28



HISTORIC AMERICAN ENGINEERING RECORD
SEE INDEX TO PHOTOGRAPHS FOR CAPTION

HAER No NV-47-29



HISTORIC AMERICAN ENGINEERING RECORD
SEE INDEX TO PHOTOGRAPHS FOR CAPTION

HAER No. NV-47-30



HISTORIC AMERICAN ENGINEERING RECORD
SEE INDEX TO PHOTOGRAPHS FOR CAPTION

HAER No. NV-47-31



HISTORIC AMERICAN ENGINEERING RECORD
SEE INDEX TO PHOTOGRAPHS FOR CAPTION

HAER No. NV-47-32



HISTORIC AMERICAN ENGINEERING RECORD
SEE INDEX TO PHOTOGRAPHS FOR CAPTION

HAER No. NV-47-33



HISTORIC AMERICAN ENGINEERING RECORD
SEE INDEX TO PHOTOGRAPHS FOR CAPTION

HAER No. NV-47-34

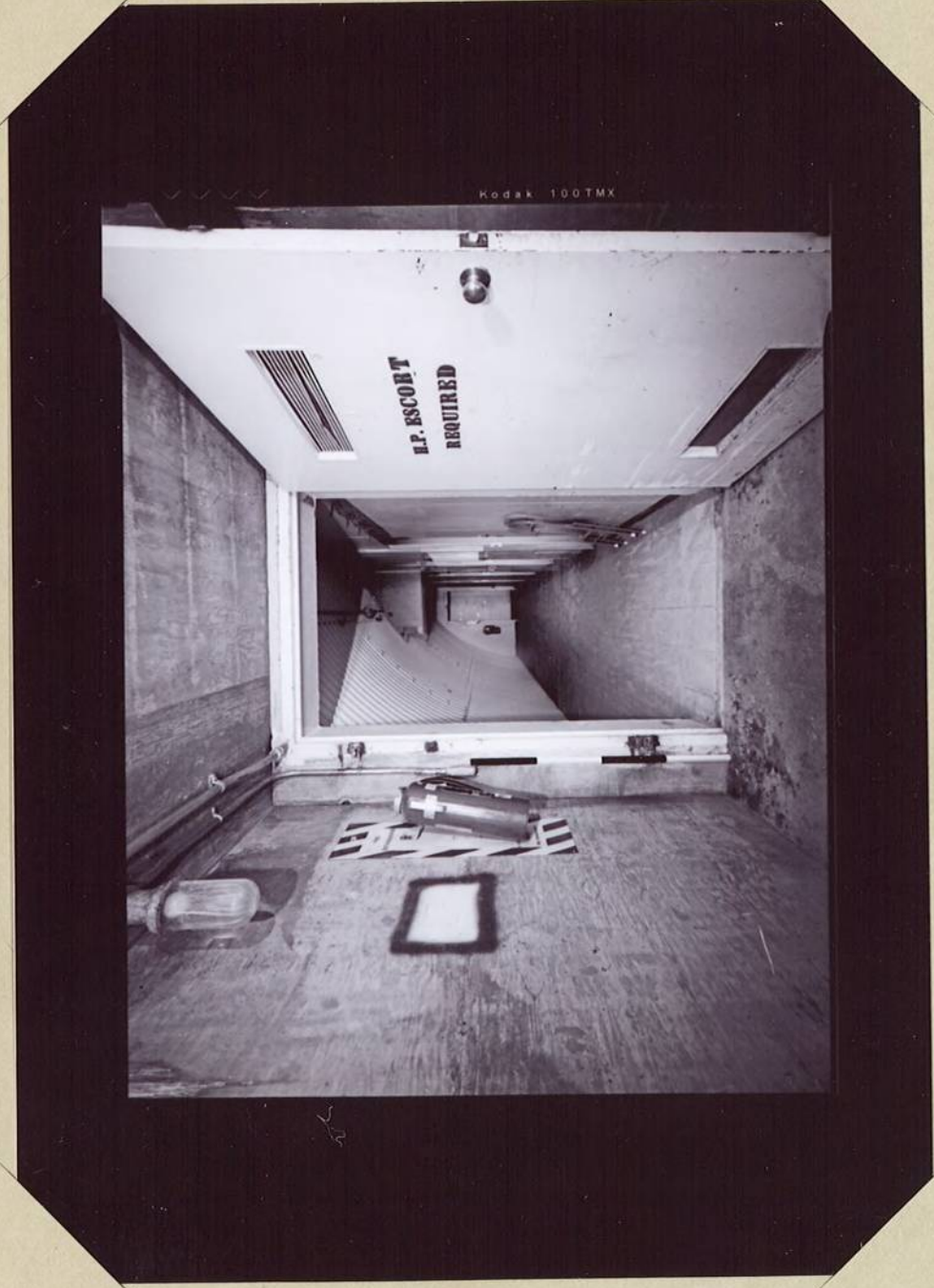

HISTORIC AMERICAN ENGINEERING RECORD
SEE INDEX TO PHOTOGRAPHS FOR CAPTION

HAER No. NV-47-35



HISTORIC AMERICAN ENGINEERING RECORD
SEE INDEX TO PHOTOGRAPHS FOR CAPTION

HAER No. NV-47-36



HISTORIC AMERICAN ENGINEERING RECORD
SEE INDEX TO PHOTOGRAPHS FOR CAPTION

HAER No. NV-47-37



HISTORIC AMERICAN ENGINEERING RECORD
SEE INDEX TO PHOTOGRAPHS FOR CAPTION

HAER No. NV-47-38



HISTORIC AMERICAN ENGINEERING RECORD
SEE INDEX TO PHOTOGRAPHS FOR CAPTION

HAER No. NV-47-39



HISTORIC AMERICAN ENGINEERING RECORD
SEE INDEX TO PHOTOGRAPHS FOR CAPTION

HAER No. NV-47-40

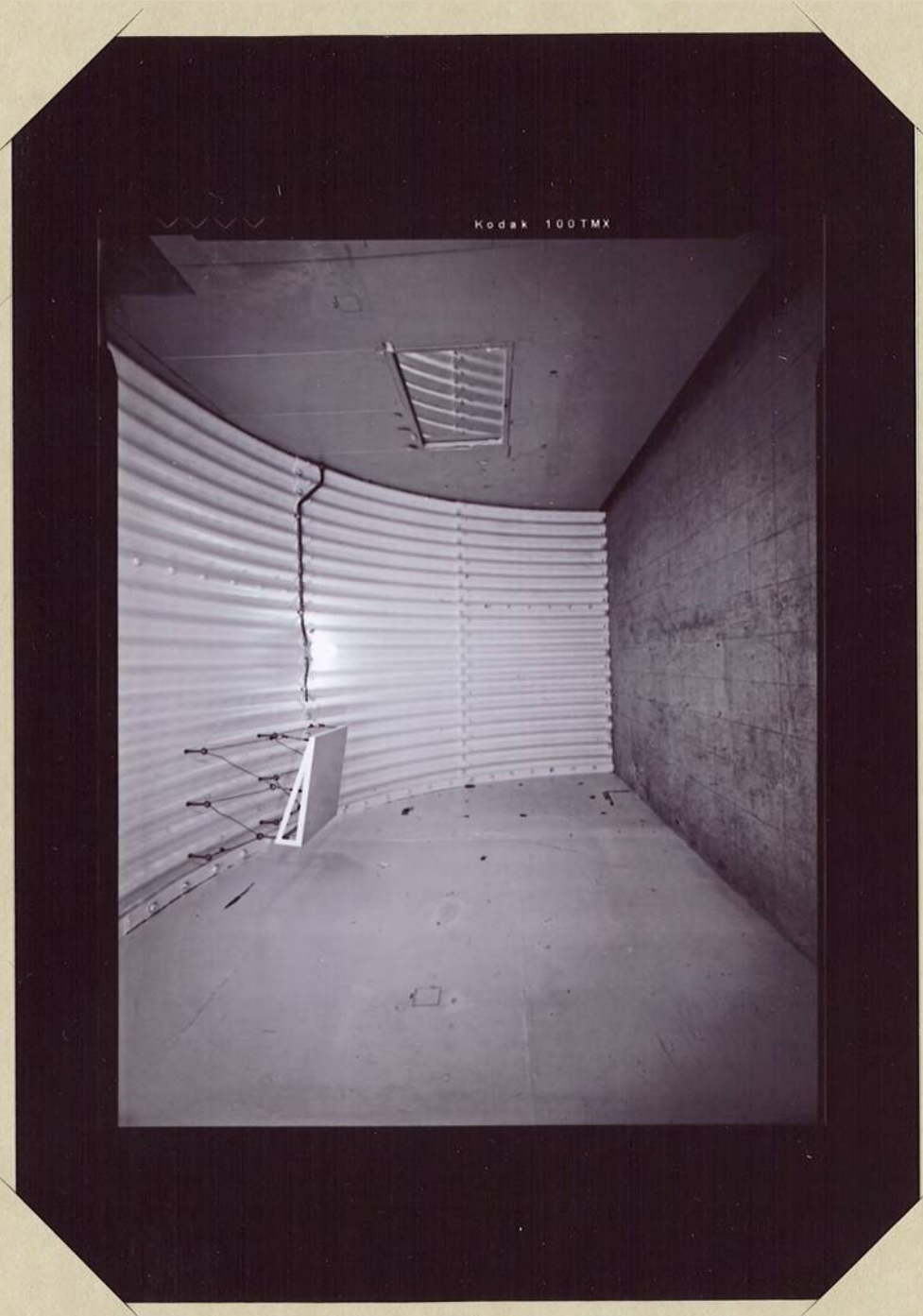

HISTORIC AMERICAN ENGINEERING RECORD
SEE INDEX TO PHOTOGRAPHS FOR CAPTION

HAER No. NV-47-41



HISTORIC AMERICAN ENGINEERING RECORD
SEE INDEX TO PHOTOGRAPHS FOR CAPTION

HAER No. NV-47-42



HISTORIC AMERICAN ENGINEERING RECORD
SEE INDEX TO PHOTOGRAPHS FOR CAPTION

HAER No. NV-47-43



HISTORIC AMERICAN ENGINEERING RECORD
SEE INDEX TO PHOTOGRAPHS FOR CAPTION

HAER No. NV-47-44



HISTORIC AMERICAN ENGINEERING RECORD
SEE INDEX TO PHOTOGRAPHS FOR CAPTION

HAER No. NV-47-45



HISTORIC AMERICAN ENGINEERING RECORD
SEE INDEX TO PHOTOGRAPHS FOR CAPTION

HAER No. NV-47-46



HISTORIC AMERICAN ENGINEERING RECORD
SEE INDEX TO PHOTOGRAPHS FOR CAPTION

HAER No. NV-47-47



HISTORIC AMERICAN ENGINEERING RECORD
SEE INDEX TO PHOTOGRAPHS FOR CAPTION

HAER No. NV-47-48



HISTORIC AMERICAN ENGINEERING RECORD
SEE INDEX TO PHOTOGRAPHS FOR CAPTION

HAER No. NV-47-49

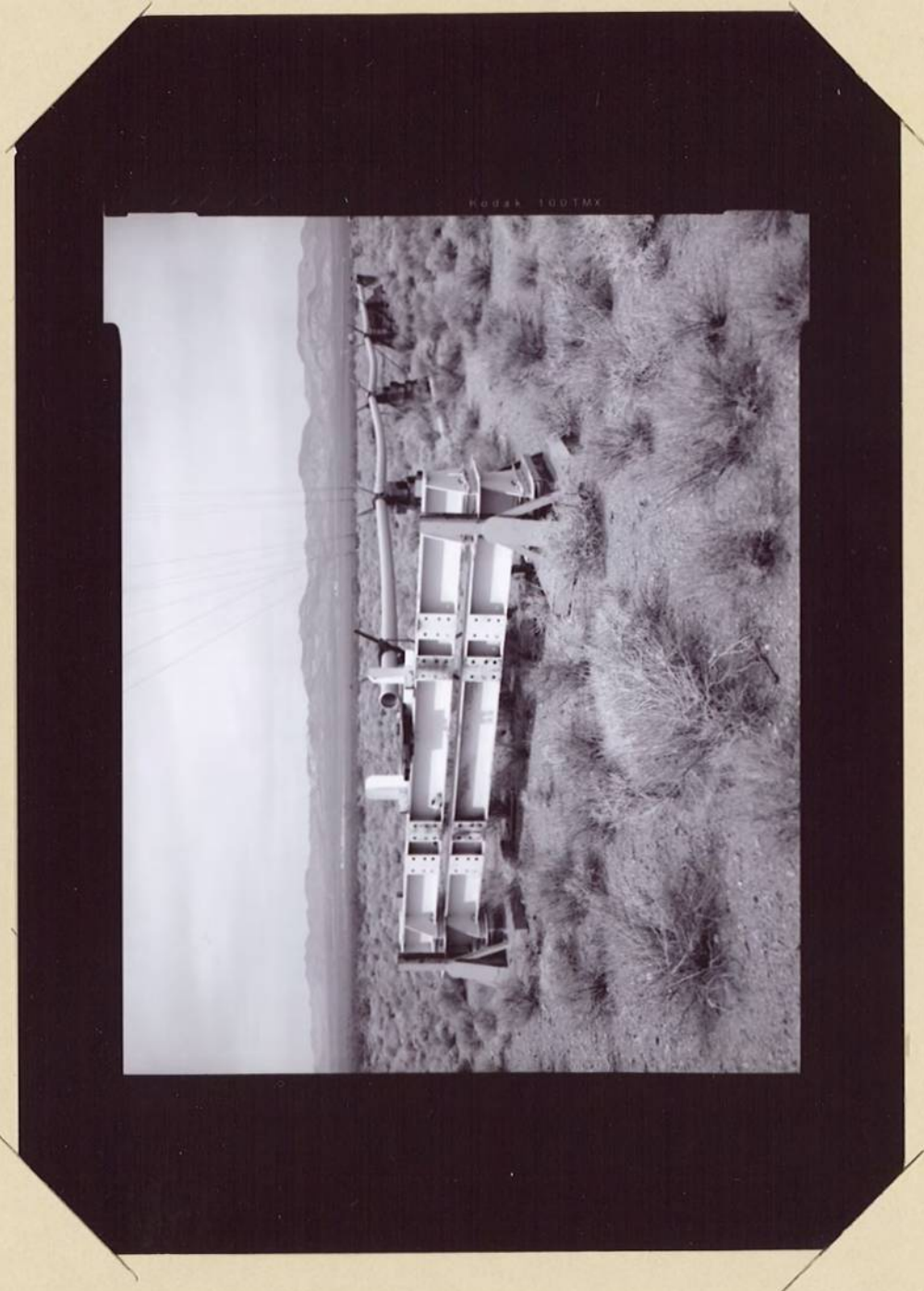

HISTORIC AMERICAN ENGINEERING RECORD
SEE INDEX TO PHOTOGRAPHS FOR CAPTION

HAER No. NV-47-50



HISTORIC AMERICAN ENGINEERING RECORD
SEE INDEX TO PHOTOGRAPHS FOR CAPTION

HAER No. NV-47-51



HISTORIC AMERICAN ENGINEERING RECORD
SEE INDEX TO PHOTOGRAPHS FOR CAPTION

HAER No. NV-47-52



HISTORIC AMERICAN ENGINEERING RECORD
SEE INDEX TO PHOTOGRAPHS FOR CAPTION

HAER No. NV-47-53



HISTORIC AMERICAN ENGINEERING RECORD
SEE INDEX TO PHOTOGRAPHS FOR CAPTION

HAER No. NV-47-54



HISTORIC AMERICAN ENGINEERING RECORD
SEE INDEX TO PHOTOGRAPHS FOR CAPTION

HAER No. NV-47-55



HISTORIC AMERICAN ENGINEERING RECORD
SEE INDEX TO PHOTOGRAPHS FOR CAPTION

HAER No. NV-47-56



HISTORIC AMERICAN ENGINEERING RECORD
SEE INDEX TO PHOTOGRAPHS FOR CAPTION

HAER No. NV-47-57



HISTORIC AMERICAN ENGINEERING RECORD
SEE INDEX TO PHOTOGRAPHS FOR CAPTION

HAER No. NV-47-58



HISTORIC AMERICAN ENGINEERING RECORD
SEE INDEX TO PHOTOGRAPHS FOR CAPTION

HAER No. NV-47-59



HISTORIC AMERICAN ENGINEERING RECORD
SEE INDEX TO PHOTOGRAPHS FOR CAPTION

HAER No. NV-47-60

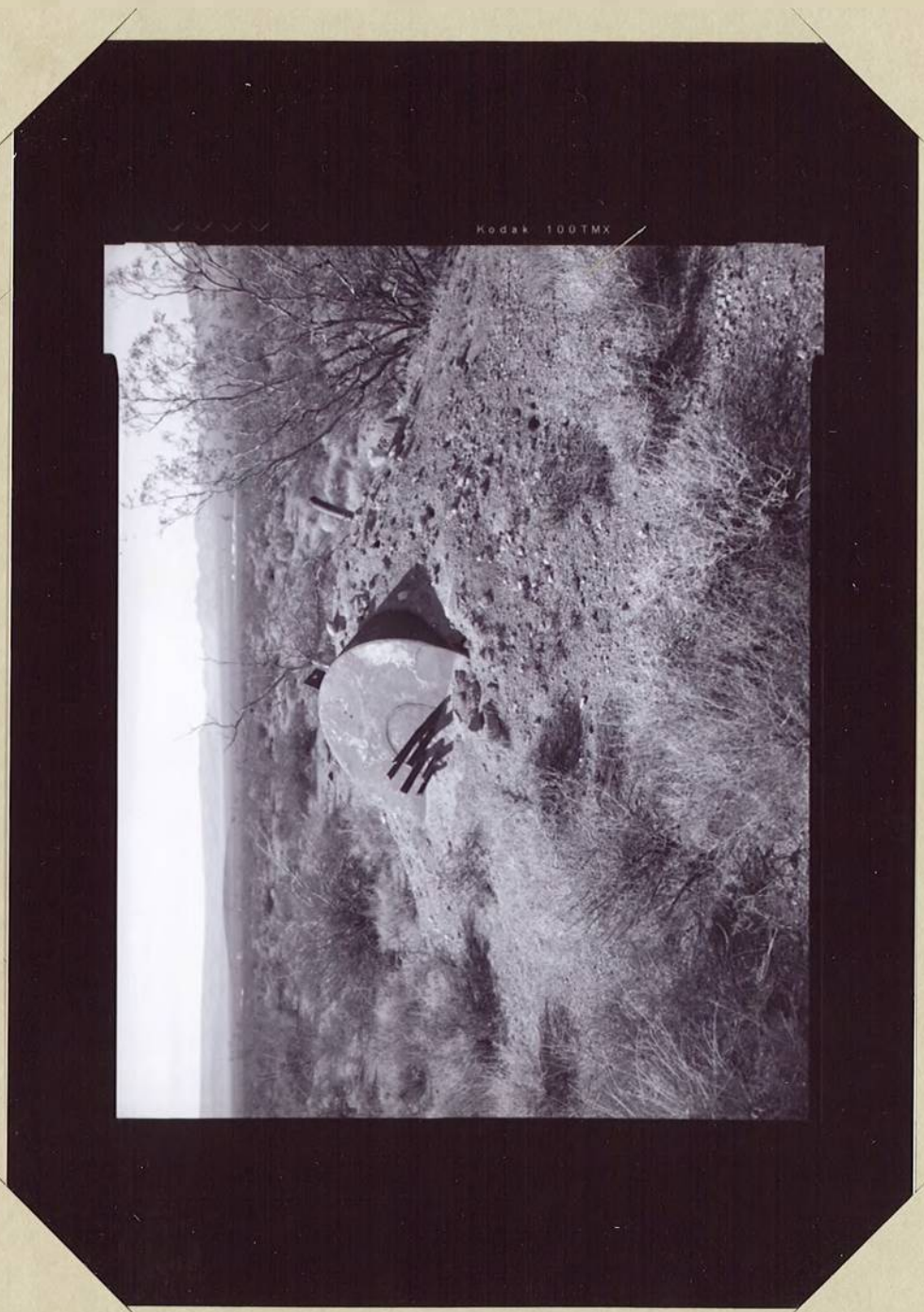

HISTORIC AMERICAN ENGINEERING RECORD
SEE INDEX TO PHOTOGRAPHS FOR CAPTION

HAER No. NV-47-61



HISTORIC AMERICAN ENGINEERING RECORD
SEE INDEX TO PHOTOGRAPHS FOR CAPTION

HAER No. NV-47-62



HISTORIC AMERICAN ENGINEERING RECORD
SEE INDEX TO PHOTOGRAPHS FOR CAPTION

HAER No. NV-47-63



HISTORIC AMERICAN ENGINEERING RECORD
SEE INDEX TO PHOTOGRAPHS FOR CAPTION

HAER No. NV-47-64



HISTORIC AMERICAN ENGINEERING RECORD
SEE INDEX TO PHOTOGRAPHS FOR CAPTION

HAER No. NV-47-65

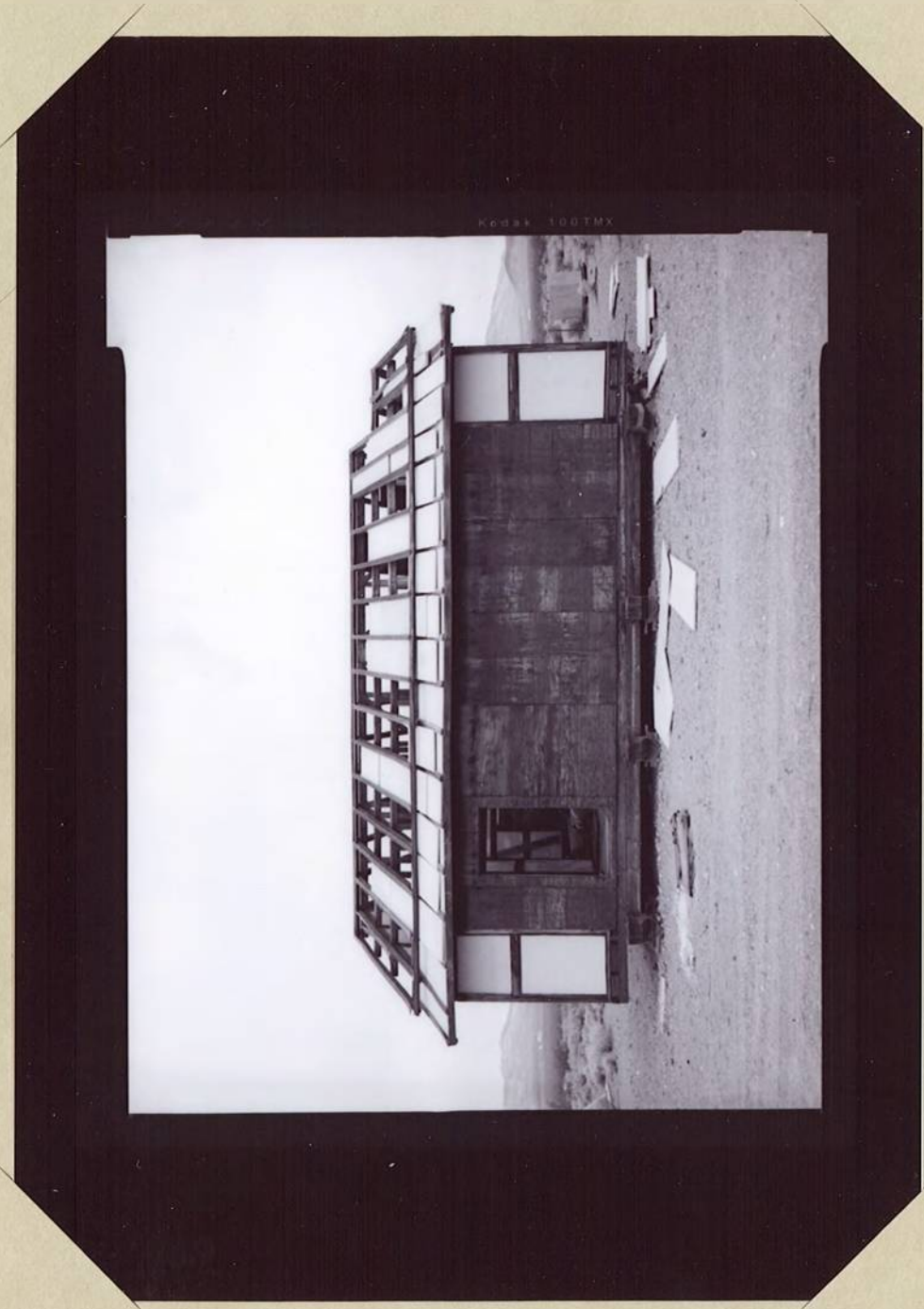

HISTORIC AMERICAN ENGINEERING RECORD
SEE INDEX TO PHOTOGRAPHS FOR CAPTION

HAER No. NV-47-66



HISTORIC AMERICAN ENGINEERING RECORD
SEE INDEX TO PHOTOGRAPHS FOR CAPTION

HAER No. NV-47-67



HISTORIC AMERICAN ENGINEERING RECORD
SEE INDEX TO PHOTOGRAPHS FOR CAPTION

HAER No. NV-47-68



HISTORIC AMERICAN ENGINEERING RECORD
SEE INDEX TO PHOTOGRAPHS FOR CAPTION

HAER No. NV-47-69



HISTORIC AMERICAN ENGINEERING RECORD
SEE INDEX TO PHOTOGRAPHS FOR CAPTION

HAER No. NV-47-70



HISTORIC AMERICAN ENGINEERING RECORD
SEE INDEX TO PHOTOGRAPHS FOR CAPTION

HAER No. NY-47-71



HISTORIC AMERICAN ENGINEERING RECORD
SEE INDEX TO PHOTOGRAPHS FOR CAPTION

HAER No. NV-47-72



HISTORIC AMERICAN ENGINEERING RECORD
SEE INDEX TO PHOTOGRAPHS FOR CAPTION

HAER No. NV-47-73



HISTORIC AMERICAN ENGINEERING RECORD
SEE INDEX TO PHOTOGRAPHS FOR CAPTION

HAER No. NV-47-74



HISTORIC AMERICAN ENGINEERING RECORD
SEE INDEX TO PHOTOGRAPHS FOR CAPTION

HAER No. NV-47-75



HISTORIC AMERICAN ENGINEERING RECORD
SEE INDEX TO PHOTOGRAPHS FOR CAPTION

HAER No. NV-47-76



HISTORIC AMERICAN ENGINEERING RECORD
SEE INDEX TO PHOTOGRAPHS FOR CAPTION

HAER No. NV-47-77



HISTORIC AMERICAN ENGINEERING RECORD
SEE INDEX TO PHOTOGRAPHS FOR CAPTION

HAER No. 44-47-78



HISTORIC AMERICAN ENGINEERING RECORD
SEE INDEX TO PHOTOGRAPHS FOR CAPTION

HAER No. NV-47-79



HISTORIC AMERICAN ENGINEERING RECORD
SEE INDEX TO PHOTOGRAPHS FOR CAPTION

HAER No. NV-47-80



HISTORIC AMERICAN ENGINEERING RECORD
SEE INDEX TO PHOTOGRAPHS FOR CAPTION

HAER No. NV-47-81



HISTORIC AMERICAN ENGINEERING RECORD
SEE INDEX TO PHOTOGRAPHS FOR CAPTION

HAER No. NV-47-82



HISTORIC AMERICAN ENGINEERING RECORD
SEE INDEX TO PHOTOGRAPHS FOR CAPTION

HAER No NV-47-83



HISTORIC AMERICAN ENGINEERING RECORD
SEE INDEX TO PHOTOGRAPHS FOR CAPTION

HAER No. NV-47-84



HISTORIC AMERICAN ENGINEERING RECORD
SEE INDEX TO PHOTOGRAPHS FOR CAPTION

HAER No. NV-47-85



HISTORIC AMERICAN ENGINEERING RECORD
SEE INDEX TO PHOTOGRAPHS FOR CAPTION

HAER No. NV-47-86

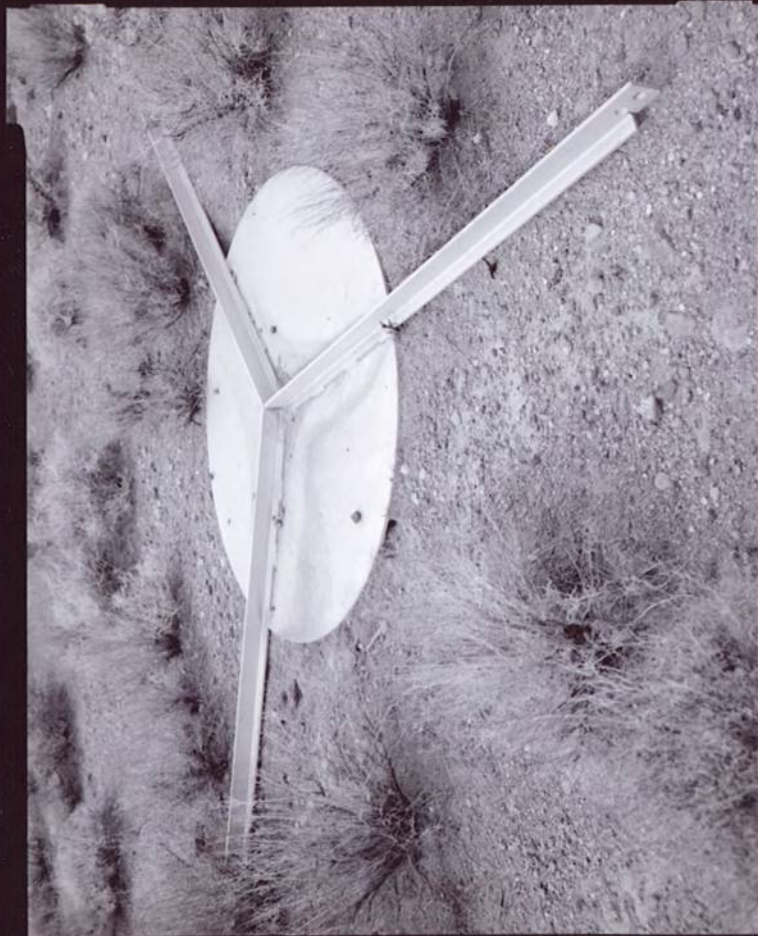

HISTORIC AMERICAN ENGINEERING RECORD
SEE INDEX TO PHOTOGRAPHS FOR CAPTION

HAER No. NV-47-87



HISTORIC AMERICAN ENGINEERING RECORD
SEE INDEX TO PHOTOGRAPHS FOR CAPTION

HAER No. NV-47-88



HISTORIC AMERICAN ENGINEERING RECORD
SEE INDEX TO PHOTOGRAPHS FOR CAPTION

HAER No. NV-47-89



HISTORIC AMERICAN ENGINEERING RECORD
SEE INDEX TO PHOTOGRAPHS FOR CAPTION

HAER No. NV-47-90

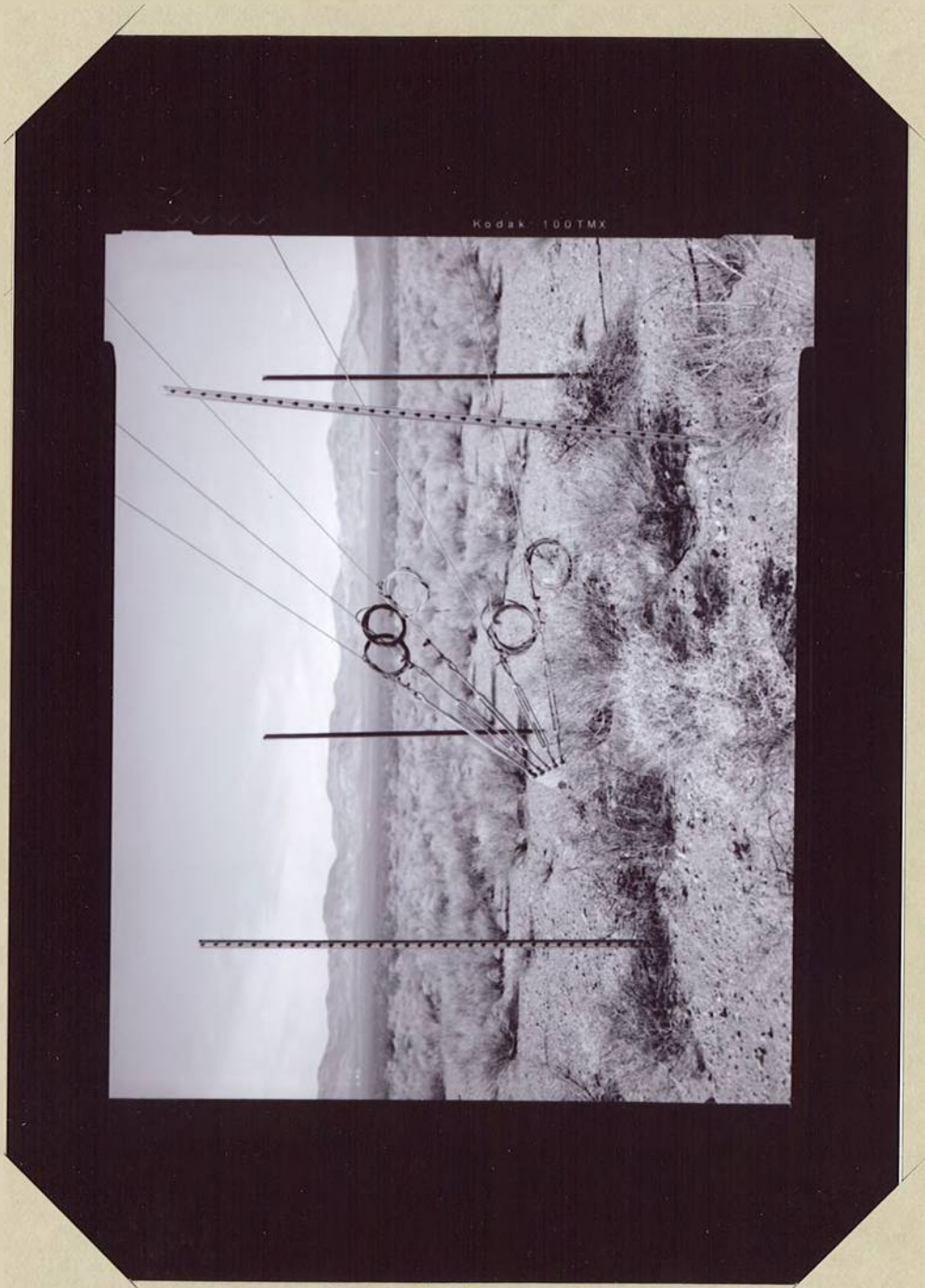

HISTORIC AMERICAN ENGINEERING RECORD
SEE INDEX TO PHOTOGRAPHS FOR CAPTION

HAER No. NV-47-91



HISTORIC AMERICAN ENGINEERING RECORD
SEE INDEX TO PHOTOGRAPHS FOR CAPTION

HAER No. NY-47-92



HISTORIC AMERICAN ENGINEERING RECORD
SEE INDEX TO PHOTOGRAPHS FOR CAPTION

HAER No. NV-47-93



HISTORIC AMERICAN ENGINEERING RECORD
SEE INDEX TO PHOTOGRAPHS FOR CAPTION

HAER No. NV-47-94



HISTORIC AMERICAN ENGINEERING RECORD
SEE INDEX TO PHOTOGRAPHS FOR CAPTION

HAER No. NV-47-95



HISTORIC AMERICAN ENGINEERING RECORD
SEE INDEX TO PHOTOGRAPHS FOR CAPTION

HAER No. NY-47-96

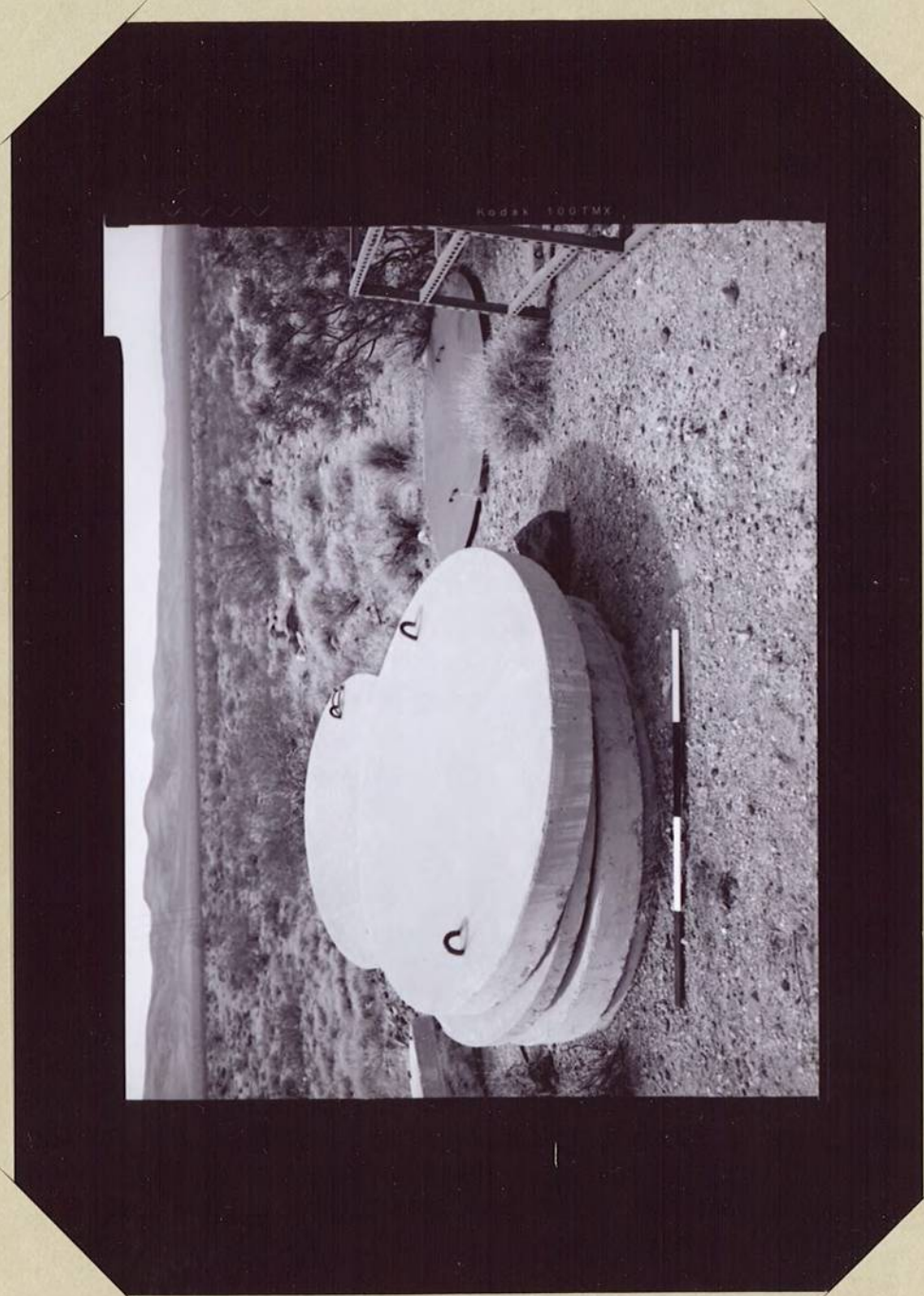

HISTORIC AMERICAN ENGINEERING RECORD
SEE INDEX TO PHOTOGRAPHS FOR CAPTION

HAER No. *NV-47-97*



HISTORIC AMERICAN ENGINEERING RECORD
SEE INDEX TO PHOTOGRAPHS FOR CAPTION

HAER No. NV-47-98



HISTORIC AMERICAN ENGINEERING RECORD
SEE INDEX TO PHOTOGRAPHS FOR CAPTION

HAER No. NV-47-99



HISTORIC AMERICAN ENGINEERING RECORD
SEE INDEX TO PHOTOGRAPHS FOR CAPTION

HAER No. NV-47-100



HISTORIC AMERICAN ENGINEERING RECORD
SEE INDEX TO PHOTOGRAPHS FOR CAPTION

HAER No. NV-47-101



HISTORIC AMERICAN ENGINEERING RECORD
SEE INDEX TO PHOTOGRAPHS FOR CAPTION

HAER No. NV-47-102



HISTORIC AMERICAN ENGINEERING RECORD
SEE INDEX TO PHOTOGRAPHS FOR CAPTION

HAER No. NV-47-103



HISTORIC AMERICAN ENGINEERING RECORD
SEE INDEX TO PHOTOGRAPHS FOR CAPTION

HAER No. NV-47-104



HISTORIC AMERICAN ENGINEERING RECORD
SEE INDEX TO PHOTOGRAPHS FOR CAPTION

HAER No. NV-47-105

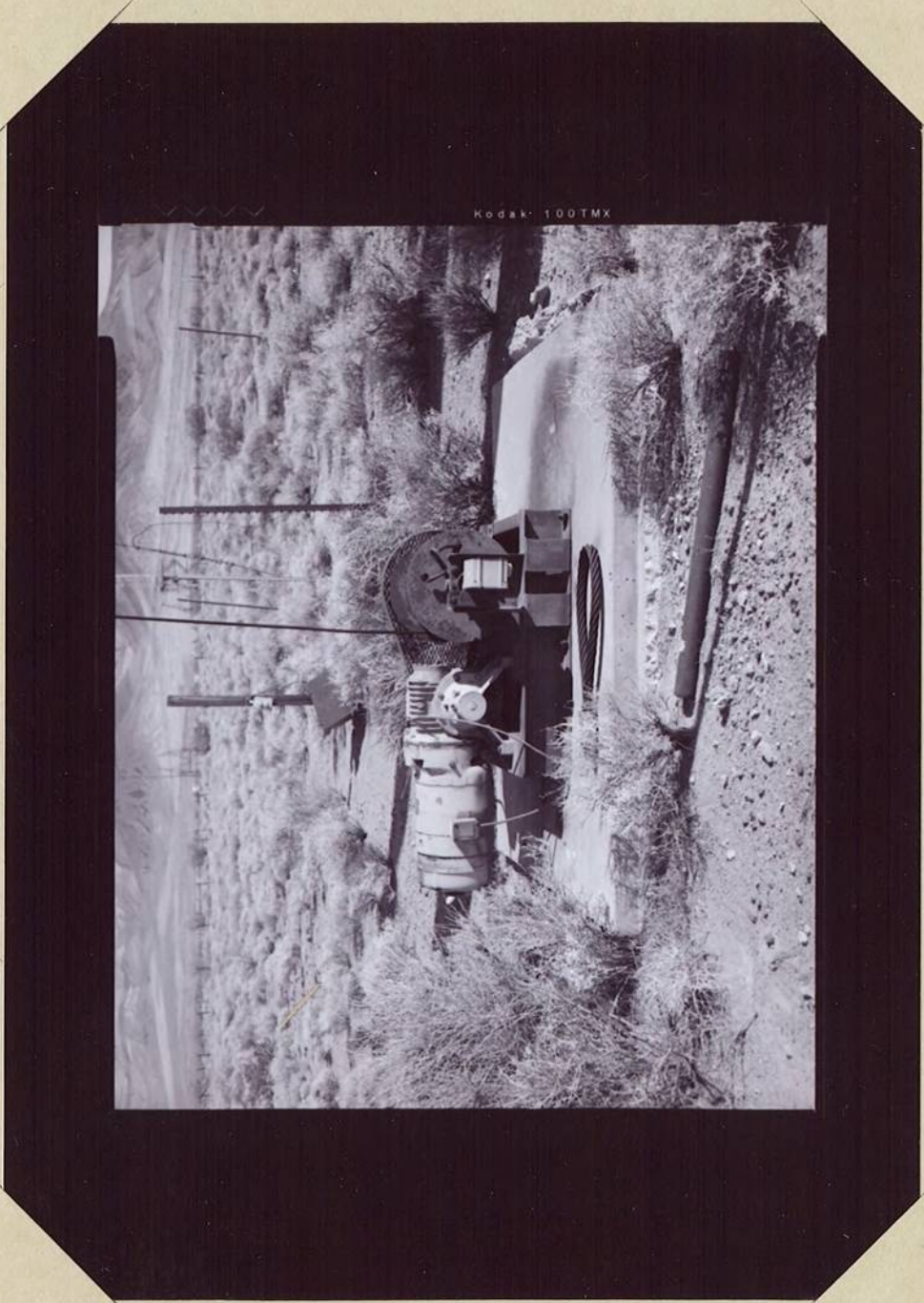

HISTORIC AMERICAN ENGINEERING RECORD
SEE INDEX TO PHOTOGRAPHS FOR CAPTION

HAER No. NV-47-106



HISTORIC AMERICAN ENGINEERING RECORD
SEE INDEX TO PHOTOGRAPHS FOR CAPTION

HAER No. NV-47-107



HISTORIC AMERICAN ENGINEERING RECORD
SEE INDEX TO PHOTOGRAPHS FOR CAPTION

HAER No. *NV-47-108*



HISTORIC AMERICAN ENGINEERING RECORD
SEE INDEX TO PHOTOGRAPHS FOR CAPTION

HAER No. NV-47-109



HISTORIC AMERICAN ENGINEERING RECORD
SEE INDEX TO PHOTOGRAPHS FOR CAPTION

HAER No. HV-47-110



HISTORIC AMERICAN ENGINEERING RECORD
SEE INDEX TO PHOTOGRAPHS FOR CAPTION

HAER No. NV-47-111



Nevada Test Site, BREN Tower Complex
(Nevada National Security Site)
Jackass Flats, Area 25
Mercury Vicinity
Nye County
Nevada

HAER NV-47

FIELD RECORDS

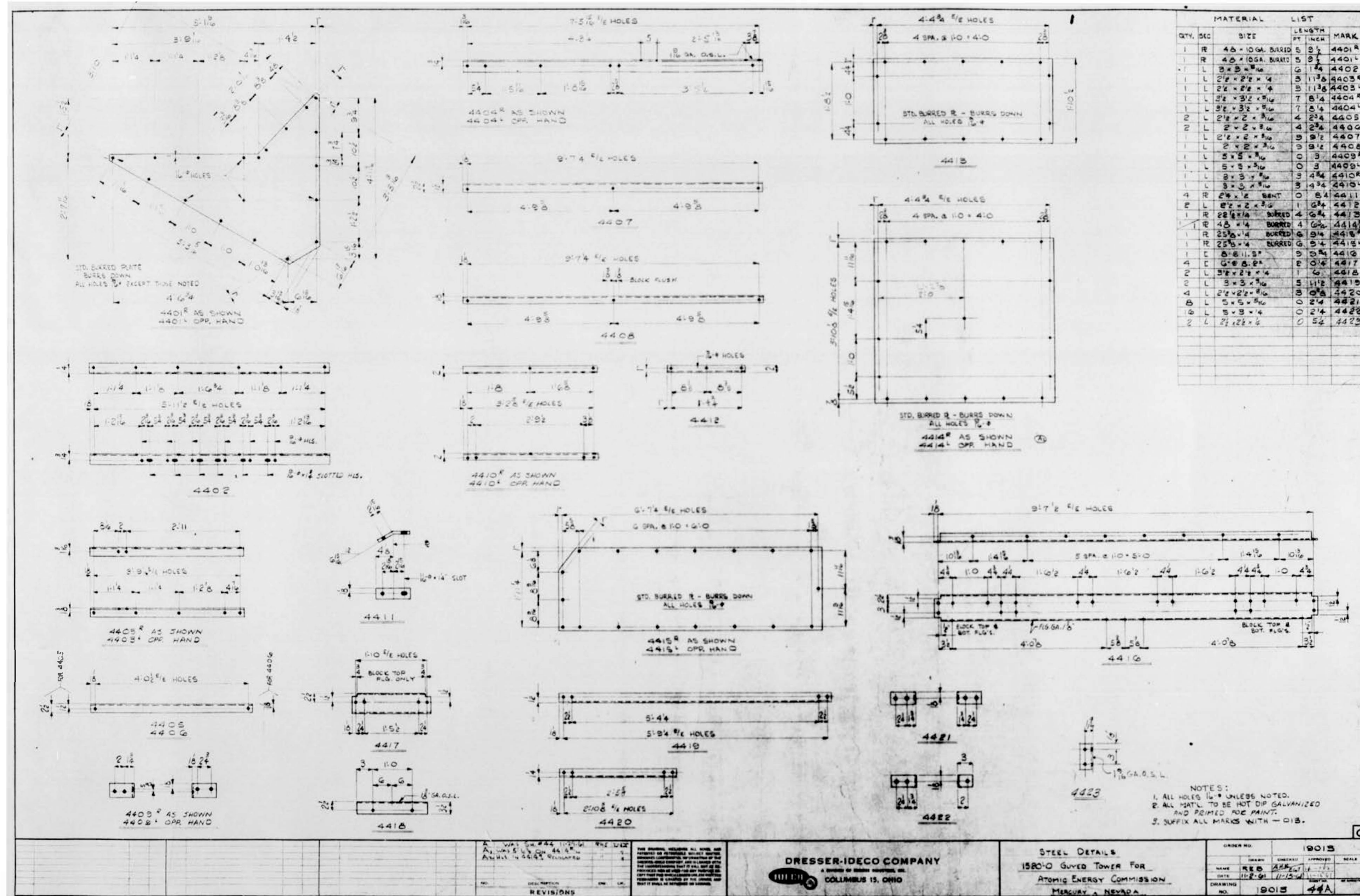

Drawing 3. Structural steel and assembly details for BREN Tower sections, Operation HENRE (Dresser-Ideco 1961c).

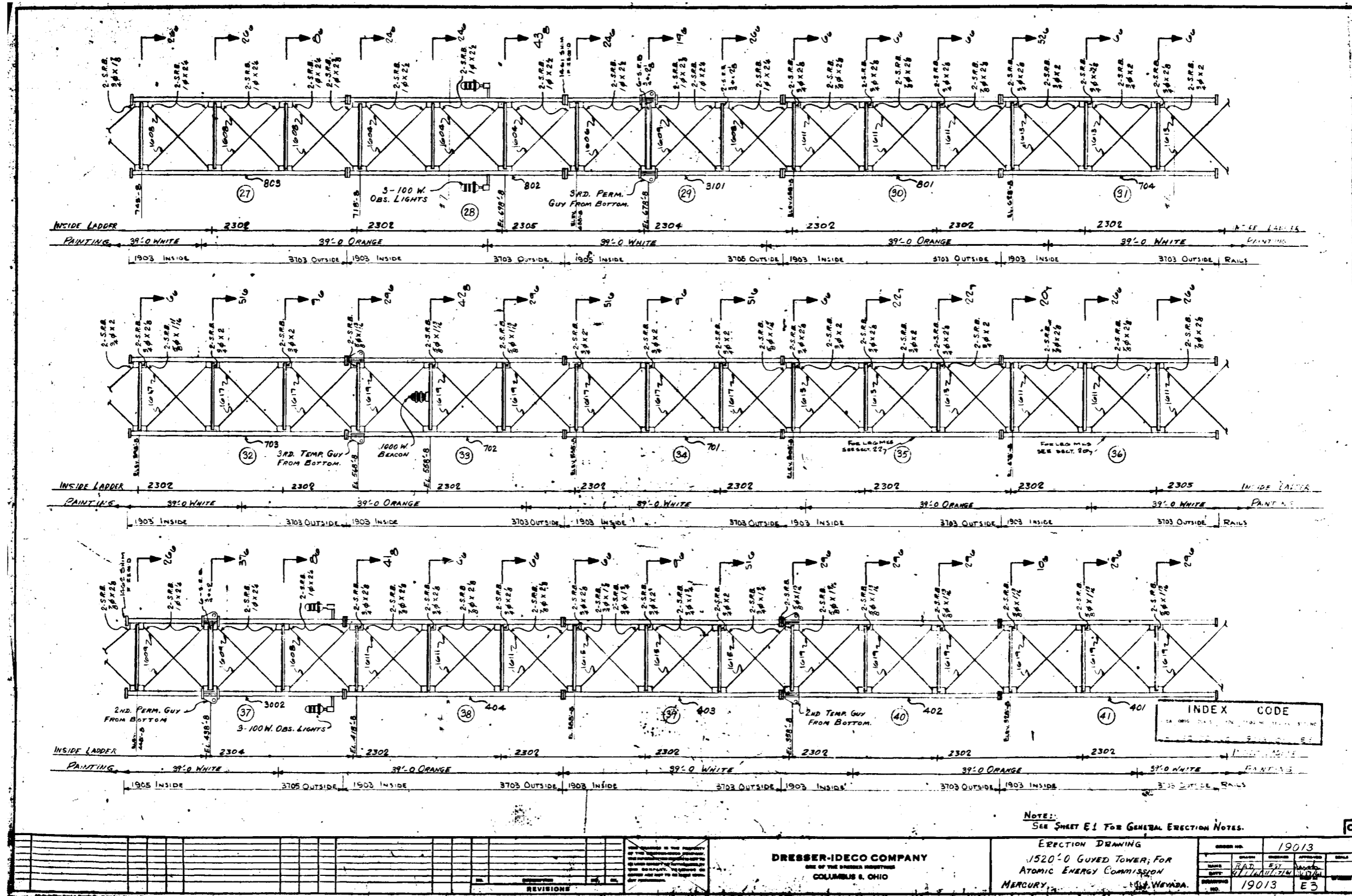

Drawing 4. Assembly details for BREN Tower sections, Operation HENRE (Dresser-Ideco 1961d).

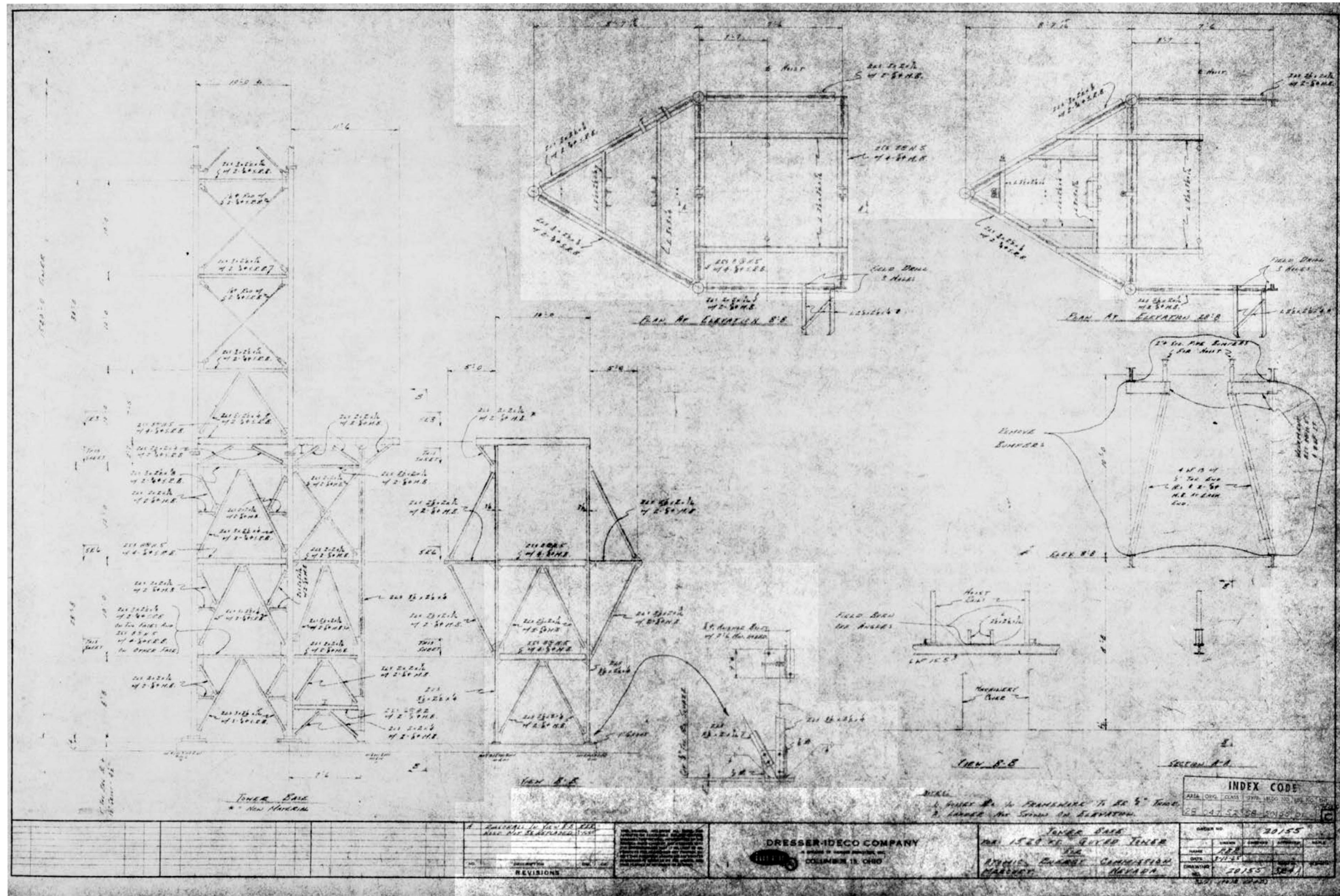

Drawing 5. Plan and cross sections for BREN Tower base section assembly of structural steel components, Operation HENRE (Dresser-Ideco 1965).

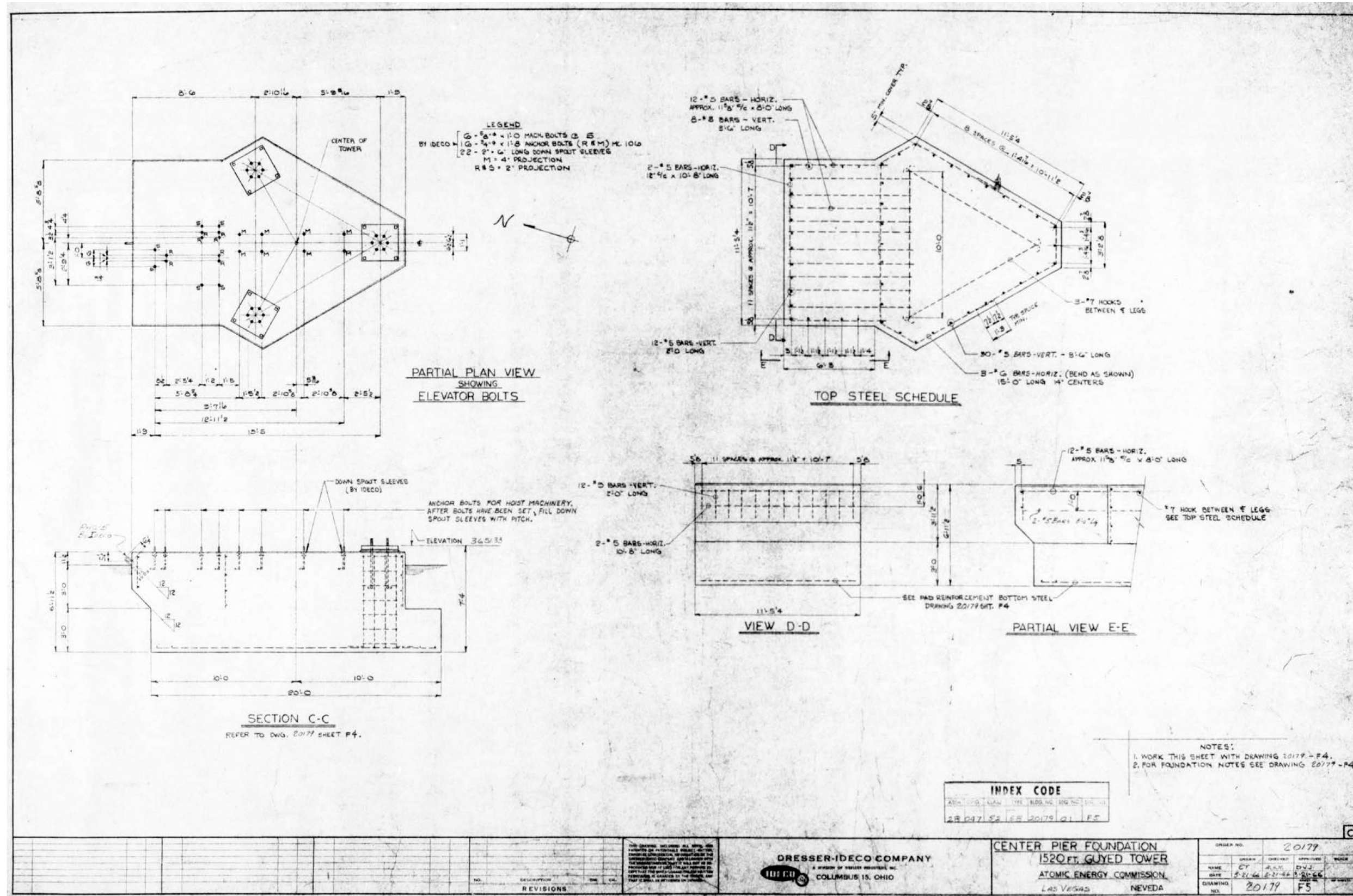

Drawing 6. Plan and cross sections for BREN Tower foundation, Operation HENRE (Dresser-Ideco 1966a).

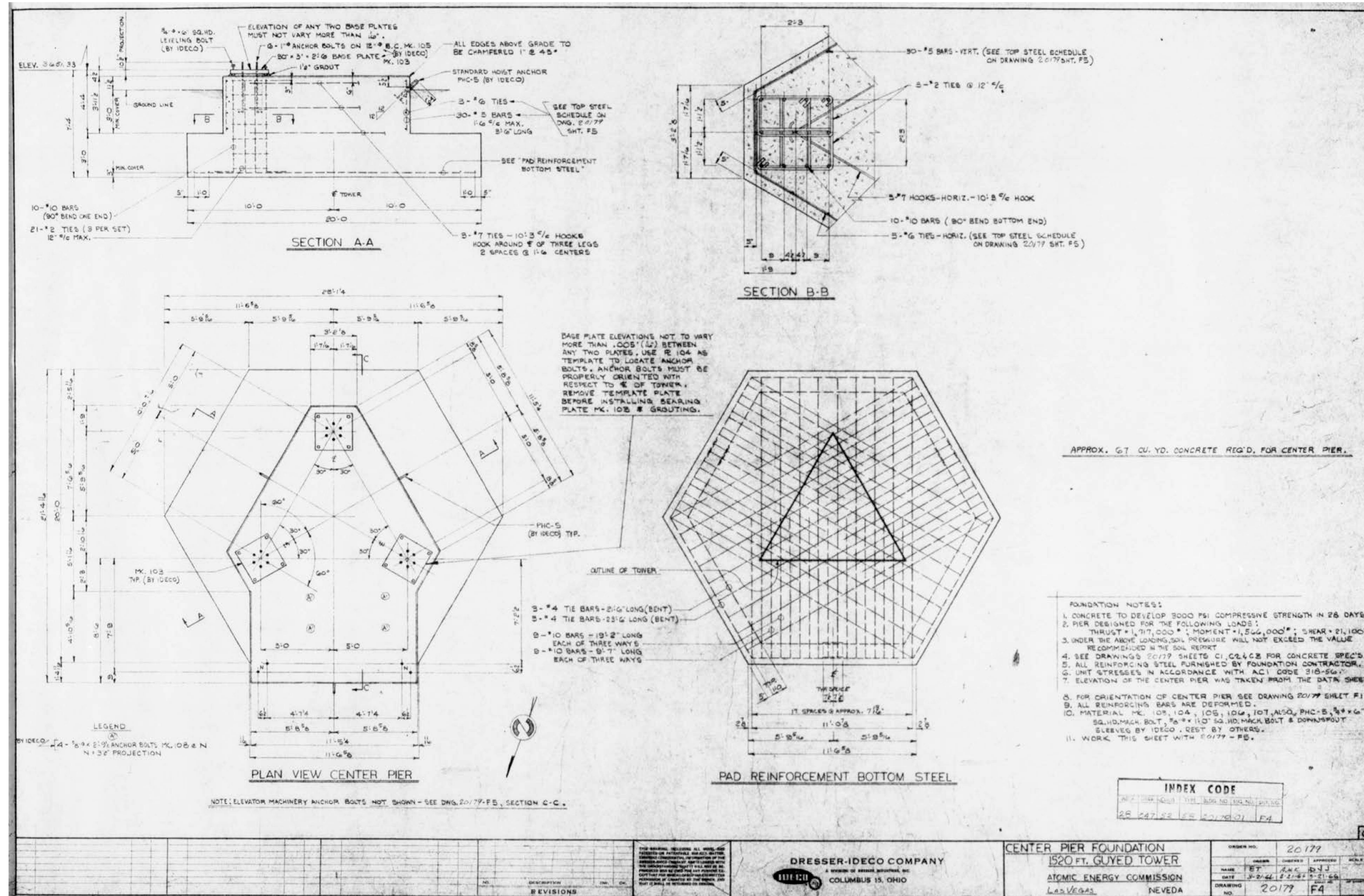

Drawing 7. Plan and cross sections for BREN Tower foundation, Operation HENRE (Dresser-Ideco 1966b).

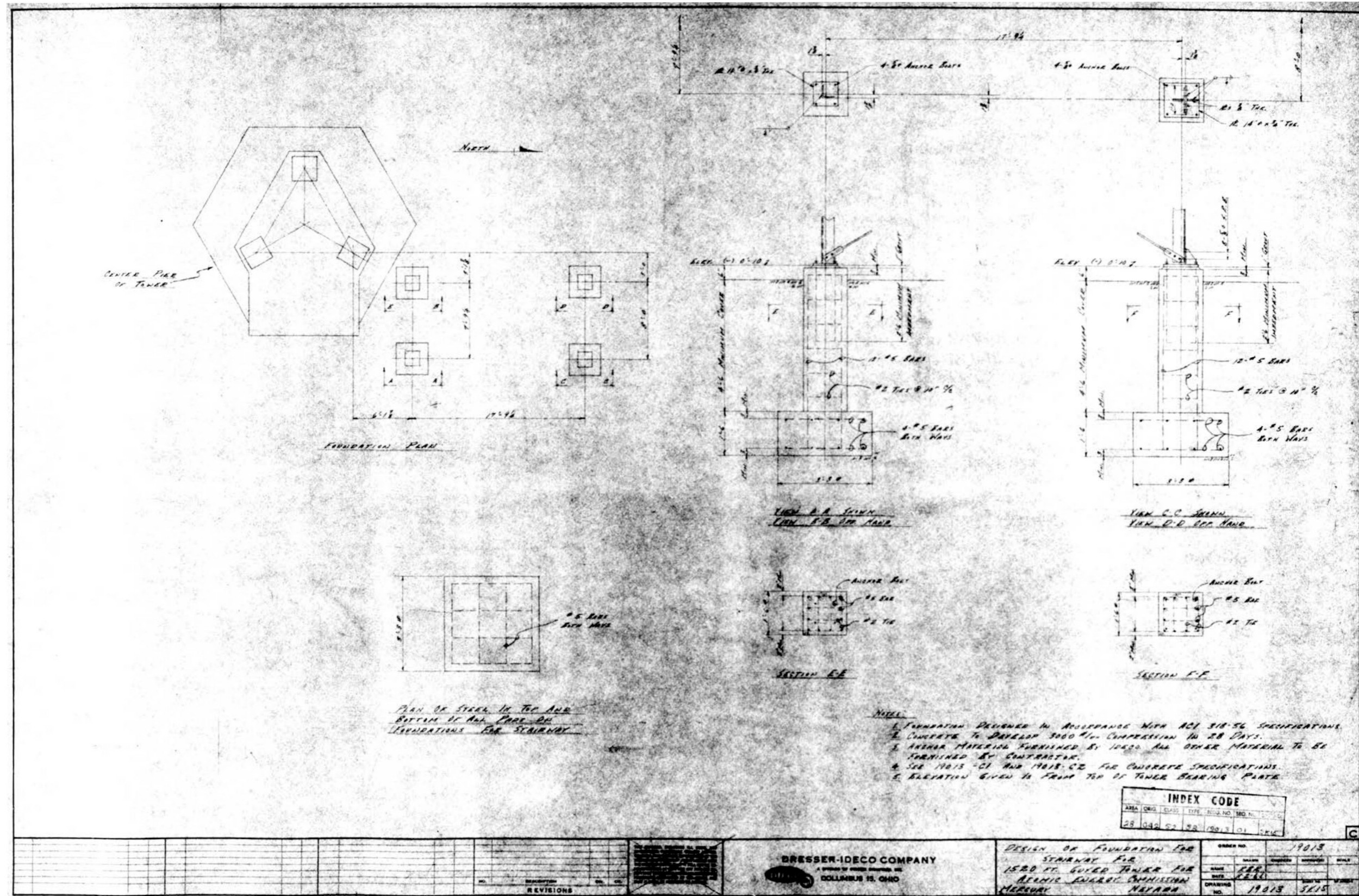

Drawing 8. Plan and cross sections for BREN Tower foundation, center pier and platform supports and staircase, Operation HENRE (Dresser-Ideco 1961e).

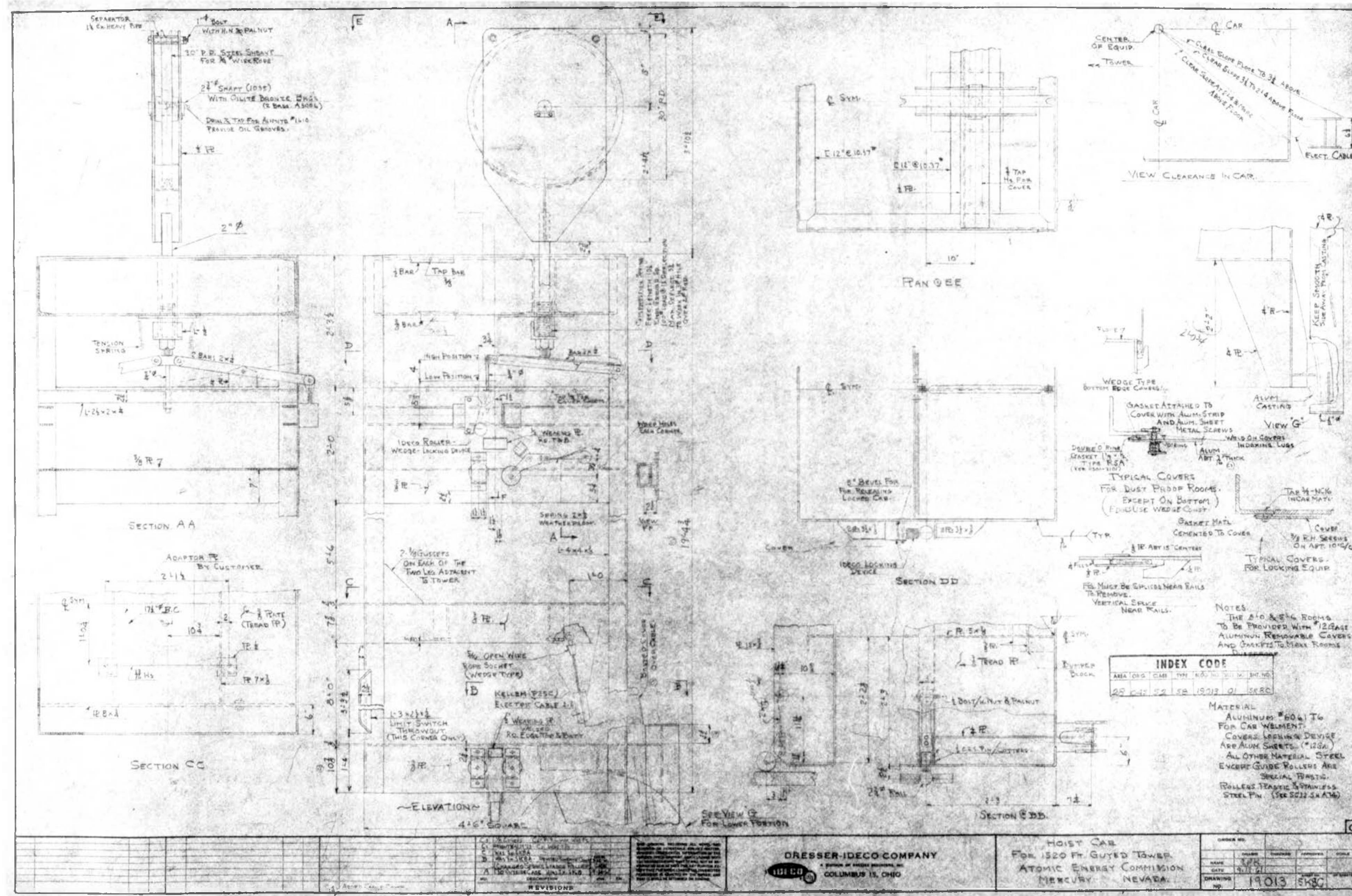

Drawing 11. Sections and details for BREN Tower Hoist Car, Operation HENRE (Dresser-Ideco 1961h) [best available copy].

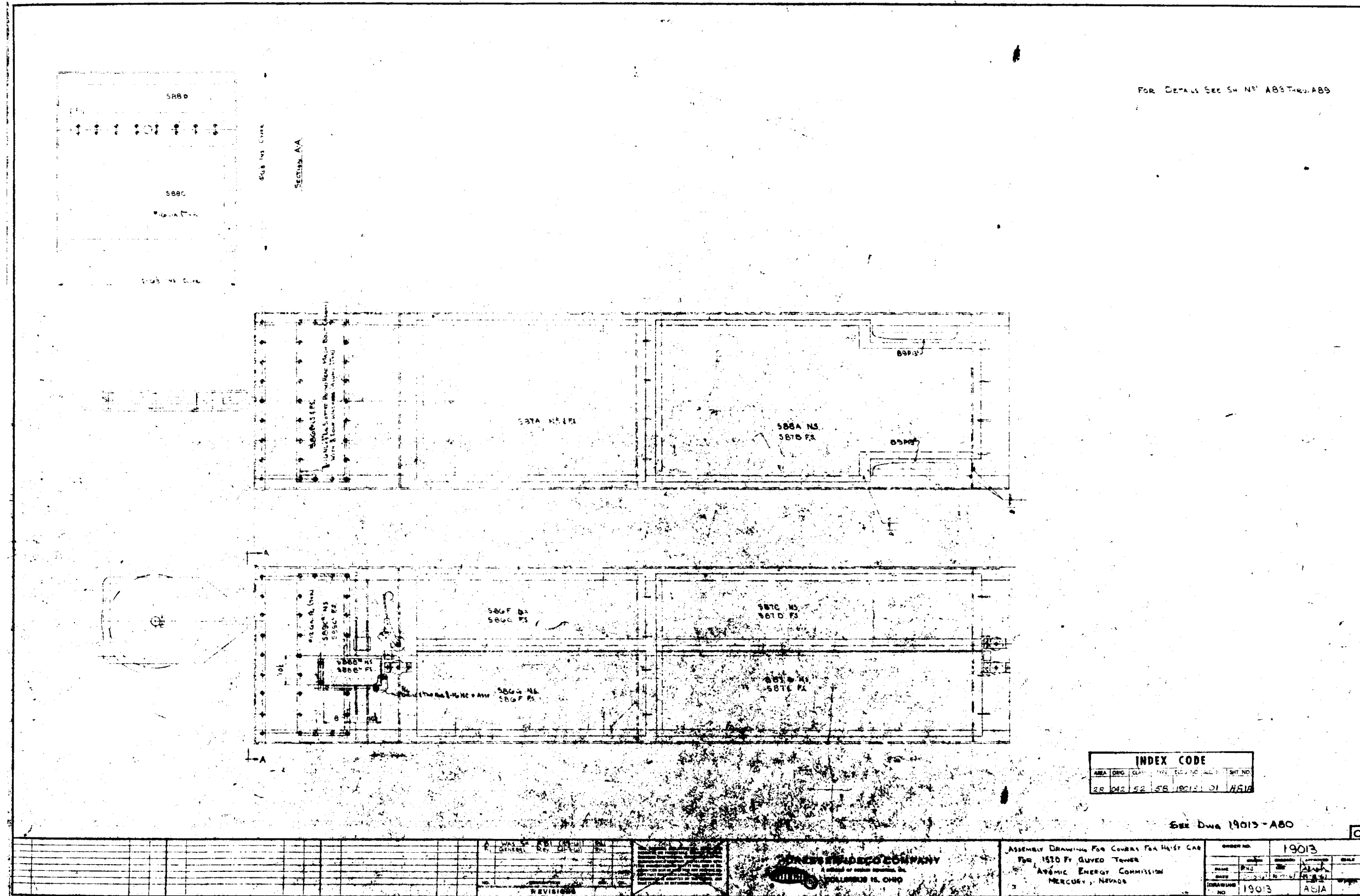

Drawing 12. Sections and details for BREN Tower Hoist Car, Operation HENRE (Dresser-Ideco 1961i) [best available copy].

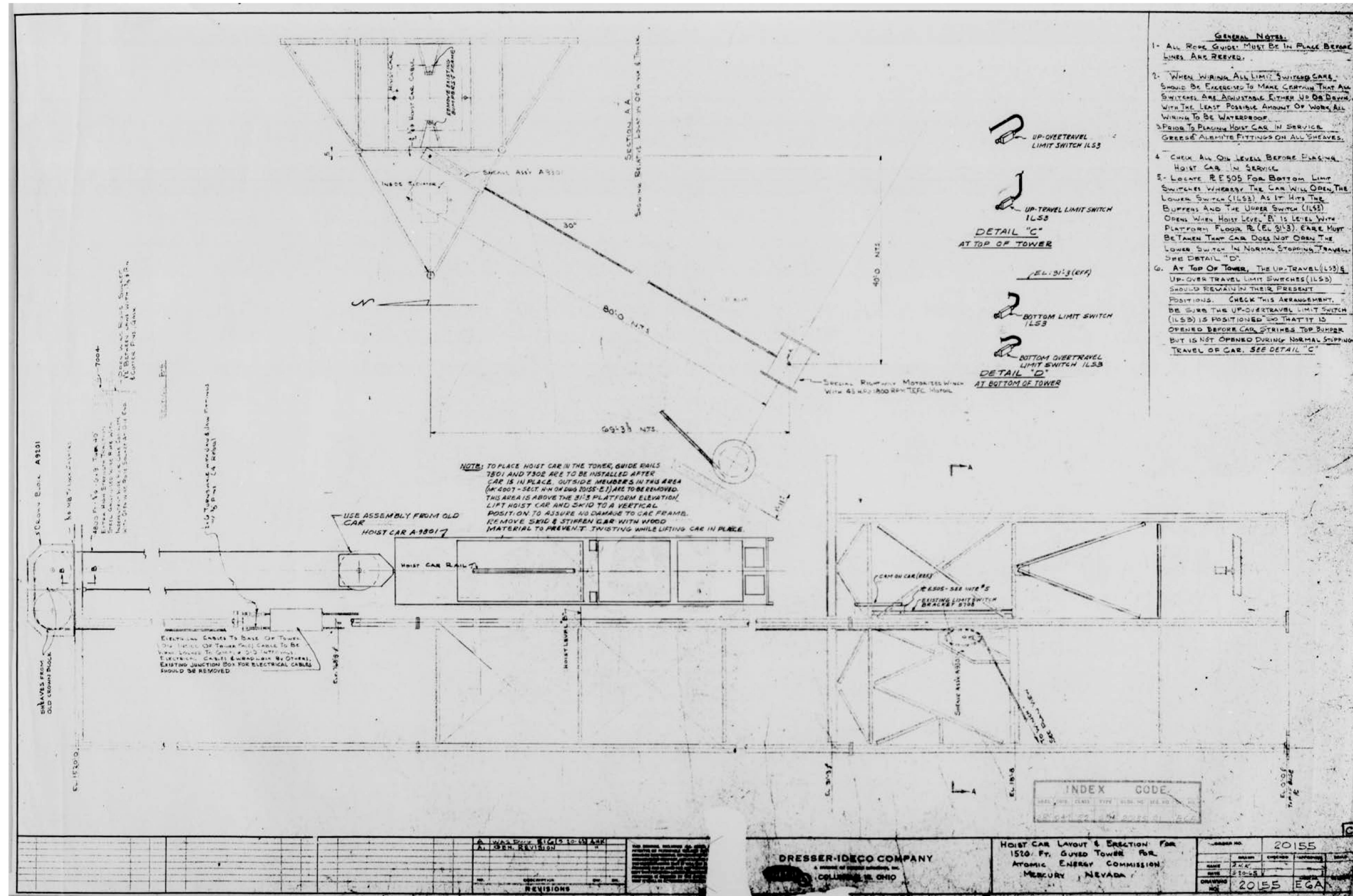

Drawing 13. Layout and assembly details for BREN Tower Hoist Car, Operation HENRE (Dresser-Ideco 1961j) [best available copy].

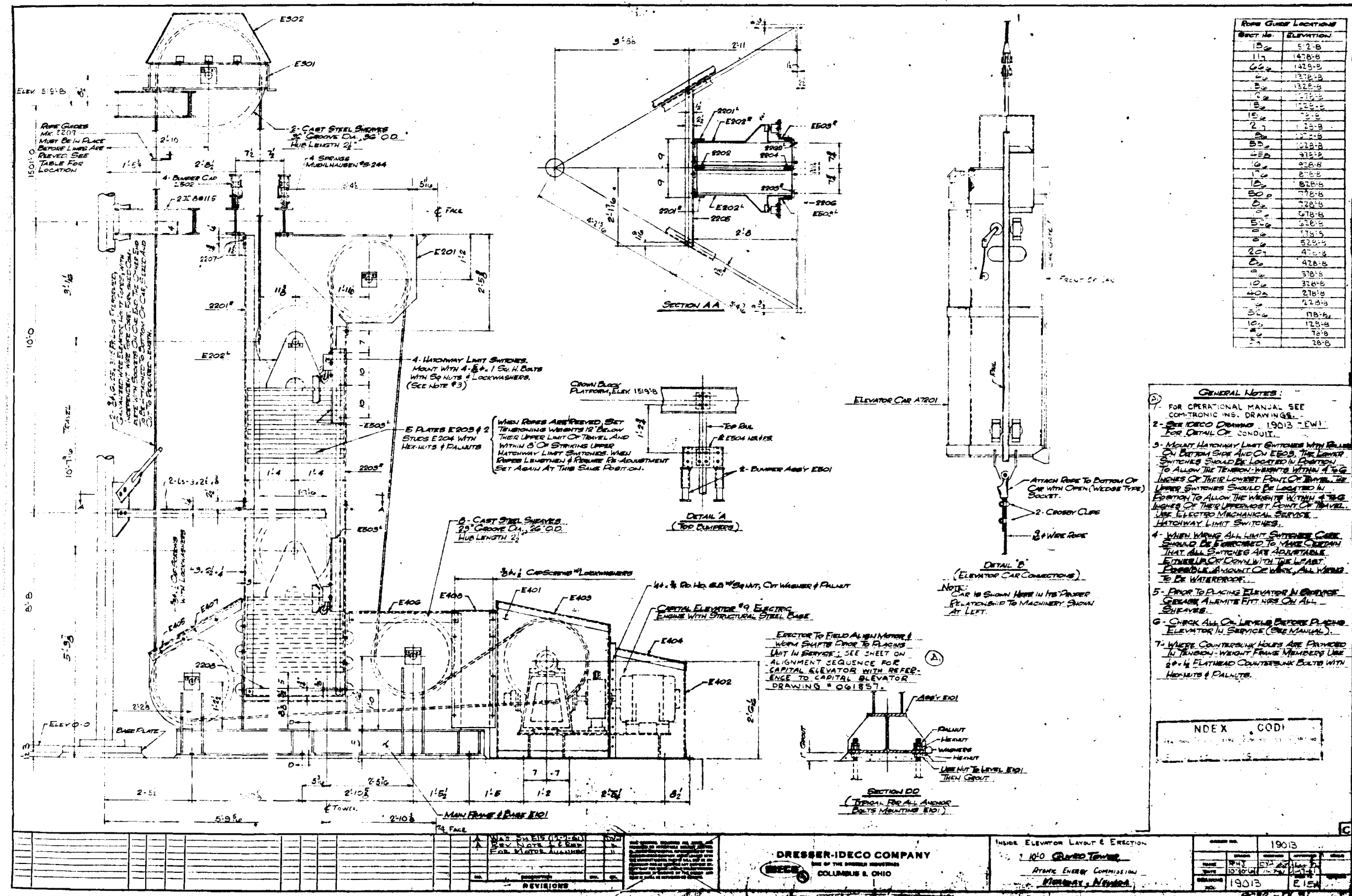

Drawing 14. Plan and layout for BREN Tower two-person elevator, Operation HENRE (Dresser-Ideco 1961k).

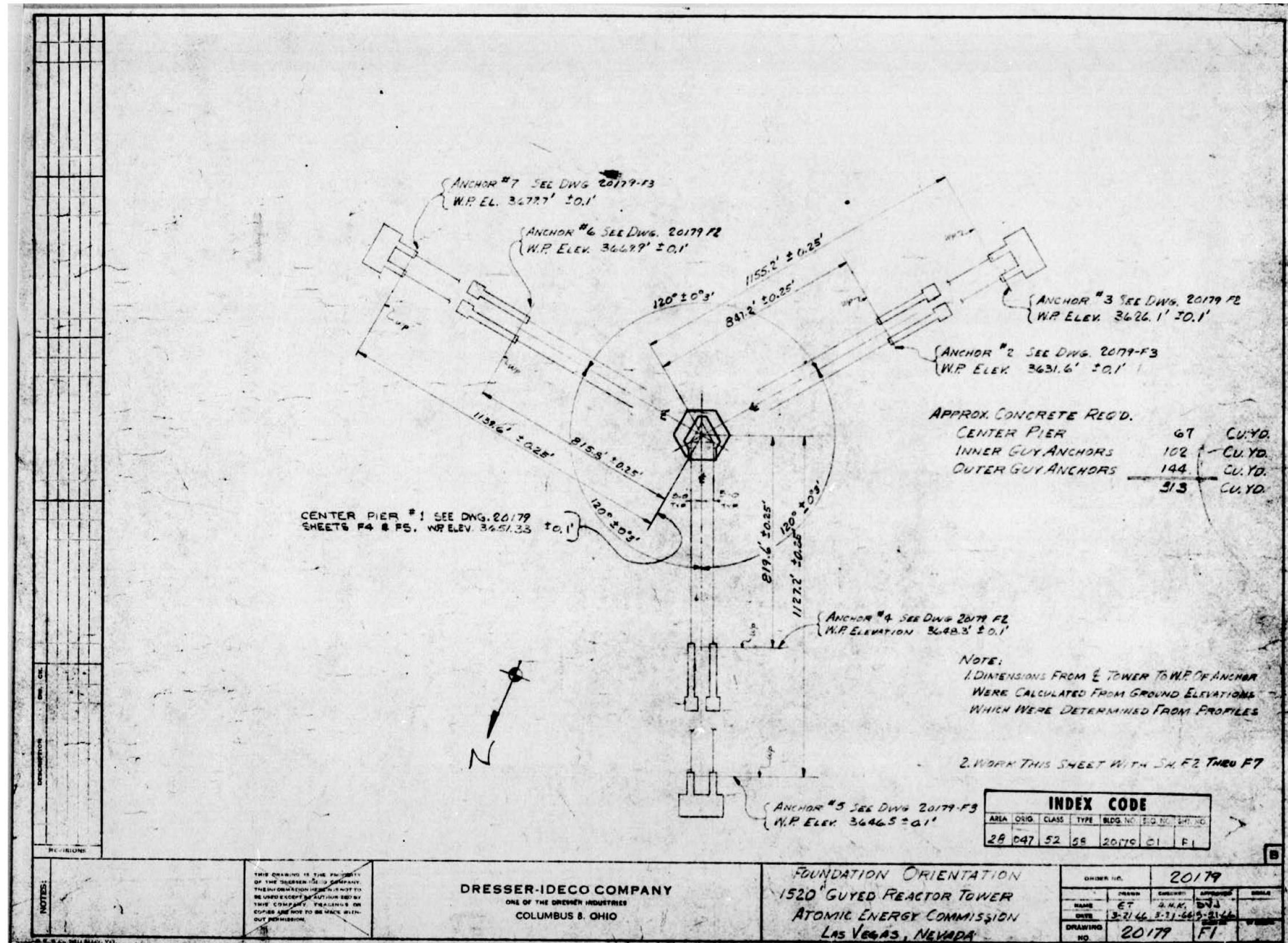

Drawing 15. Plan view for guy anchor stanchion foundations for BREN Tower, Operation HENRE (Dresser-Ideco 1966c).

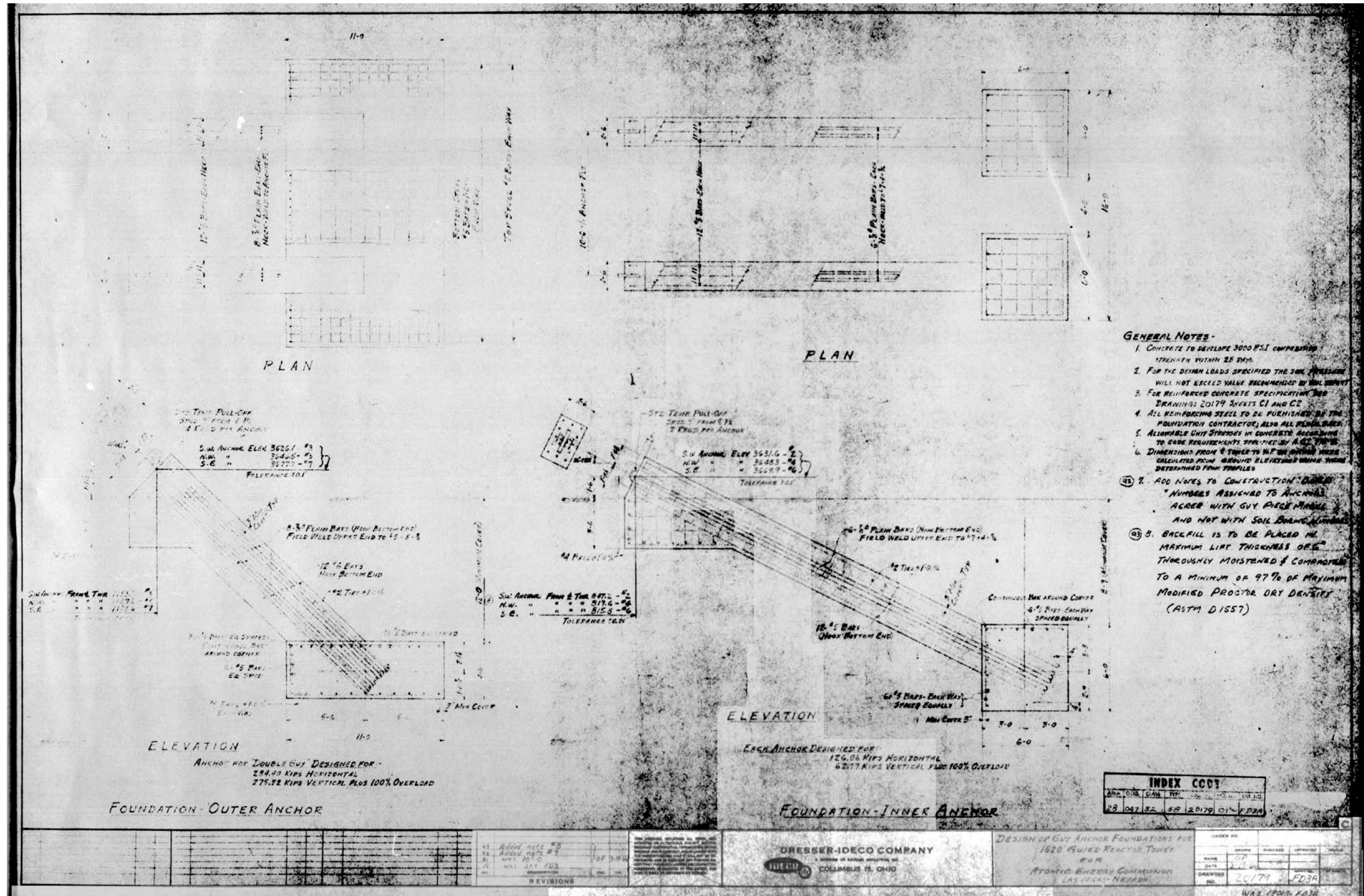

Drawing 16. Design for guy anchor stanchion foundations for BREN Tower, Operation HENRE (Dresser-Ideco 1966d).

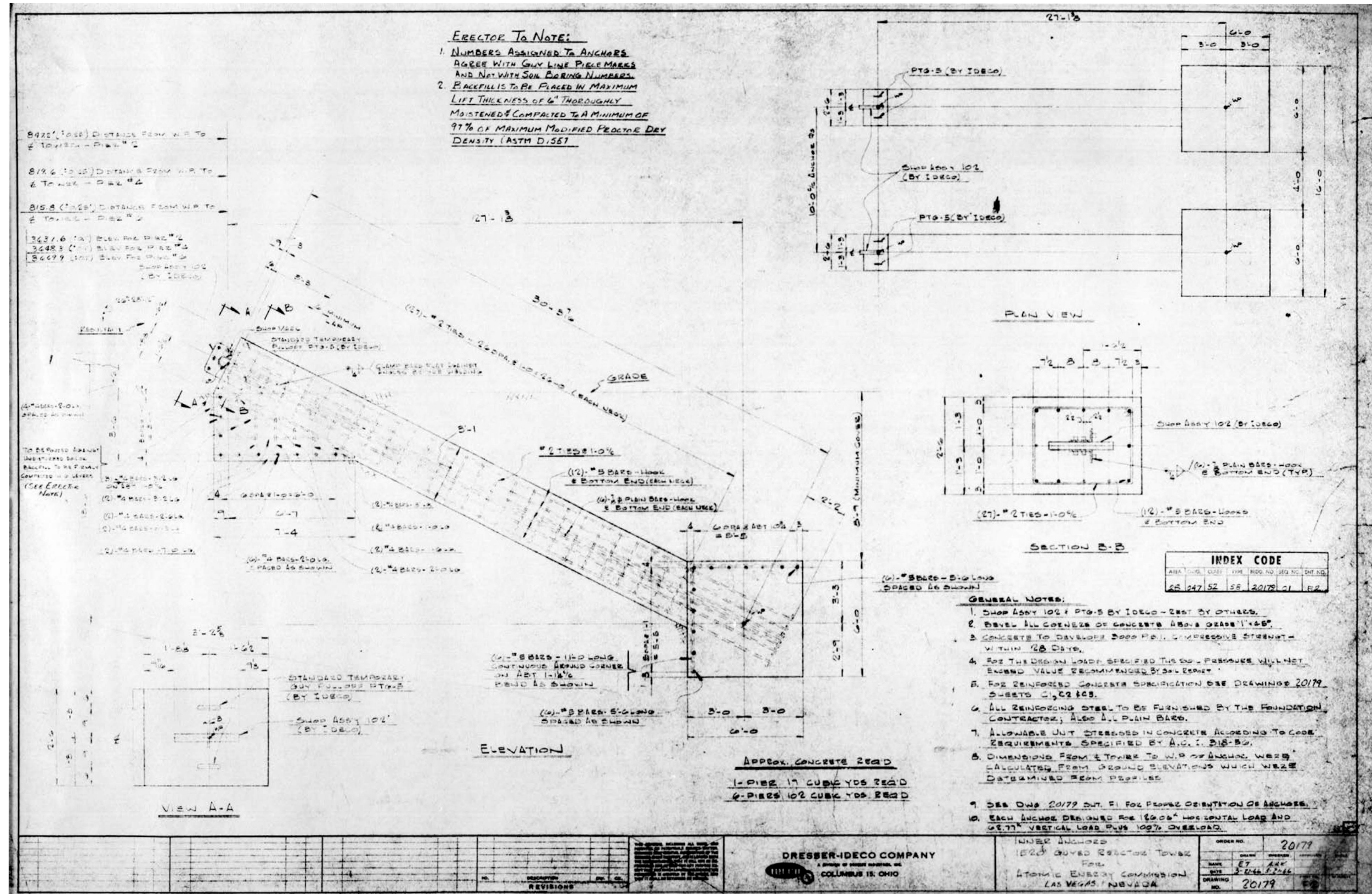

Drawing 17. Design for the inner guy anchor stanchion foundation for BREN Tower, Operation HENRE (Dresser-Ideco 1966e).

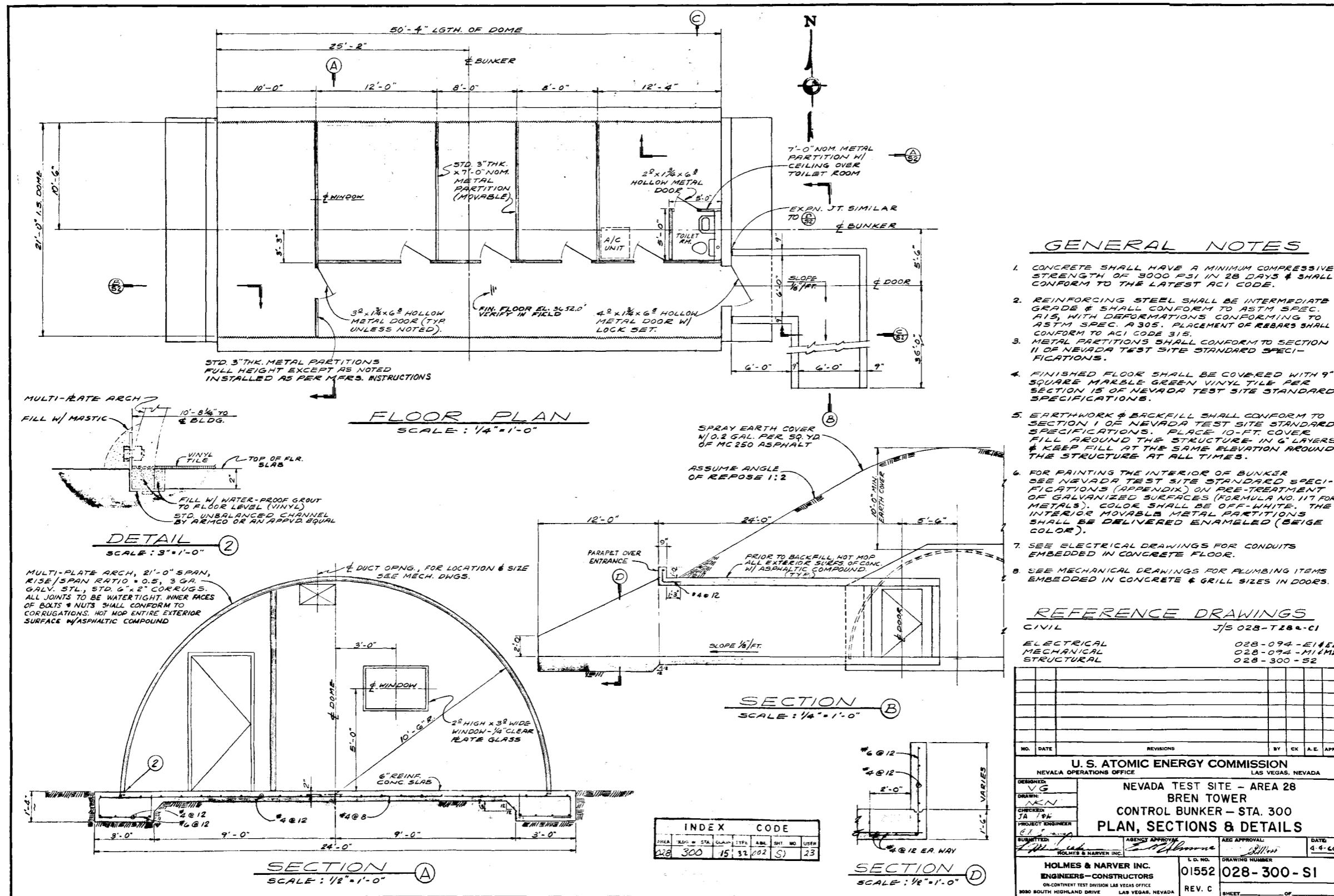

Drawing 19. Plan, cross sections and details for the Control Bunker, Operation HENRE, Support Facilities (Holmes & Narver 1966b).

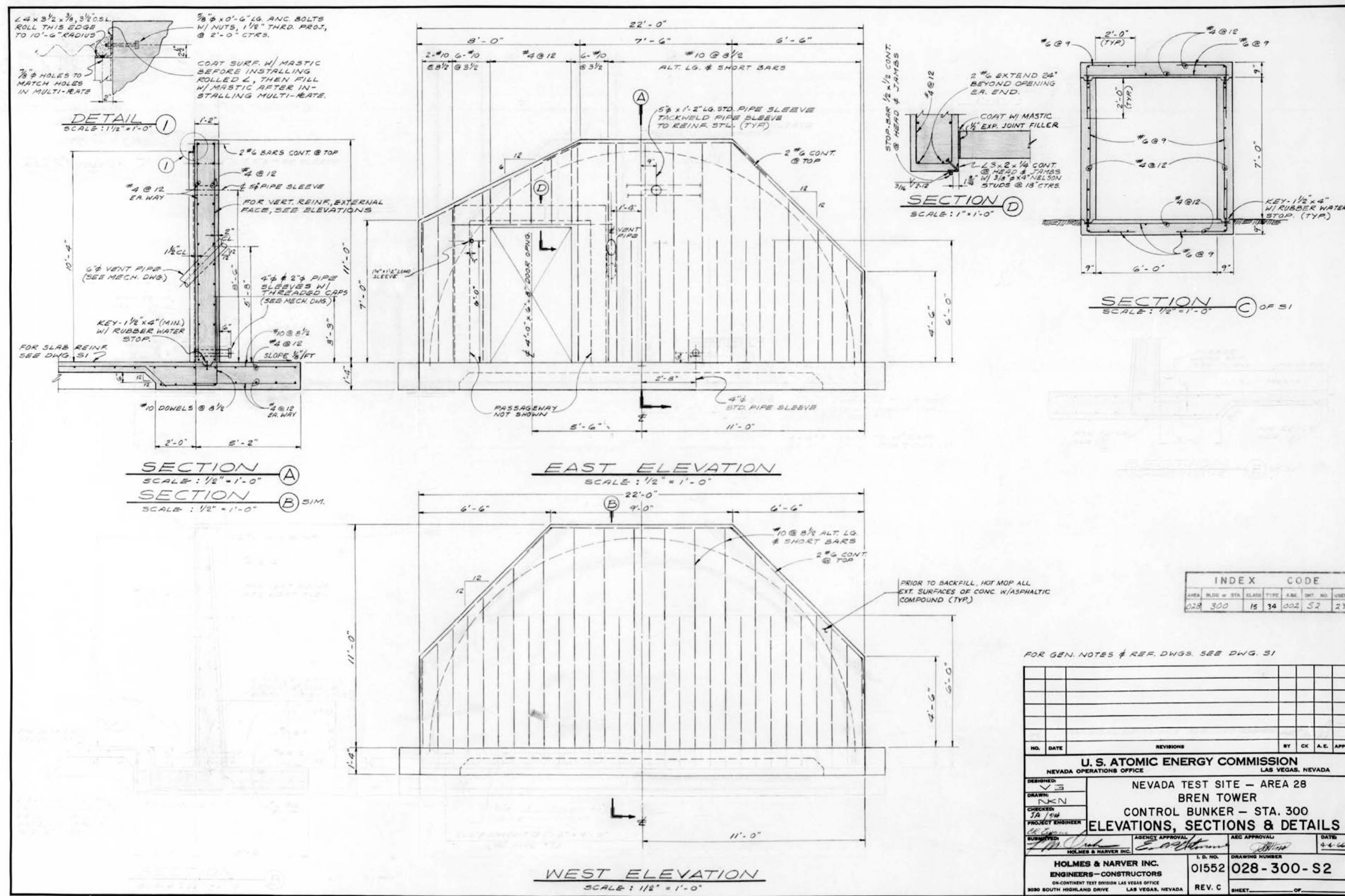

Drawing 20. Elevations and cross sections for the Control Bunker, Operation HENRE, Support Facilities (Holmes & Narver 1966c).

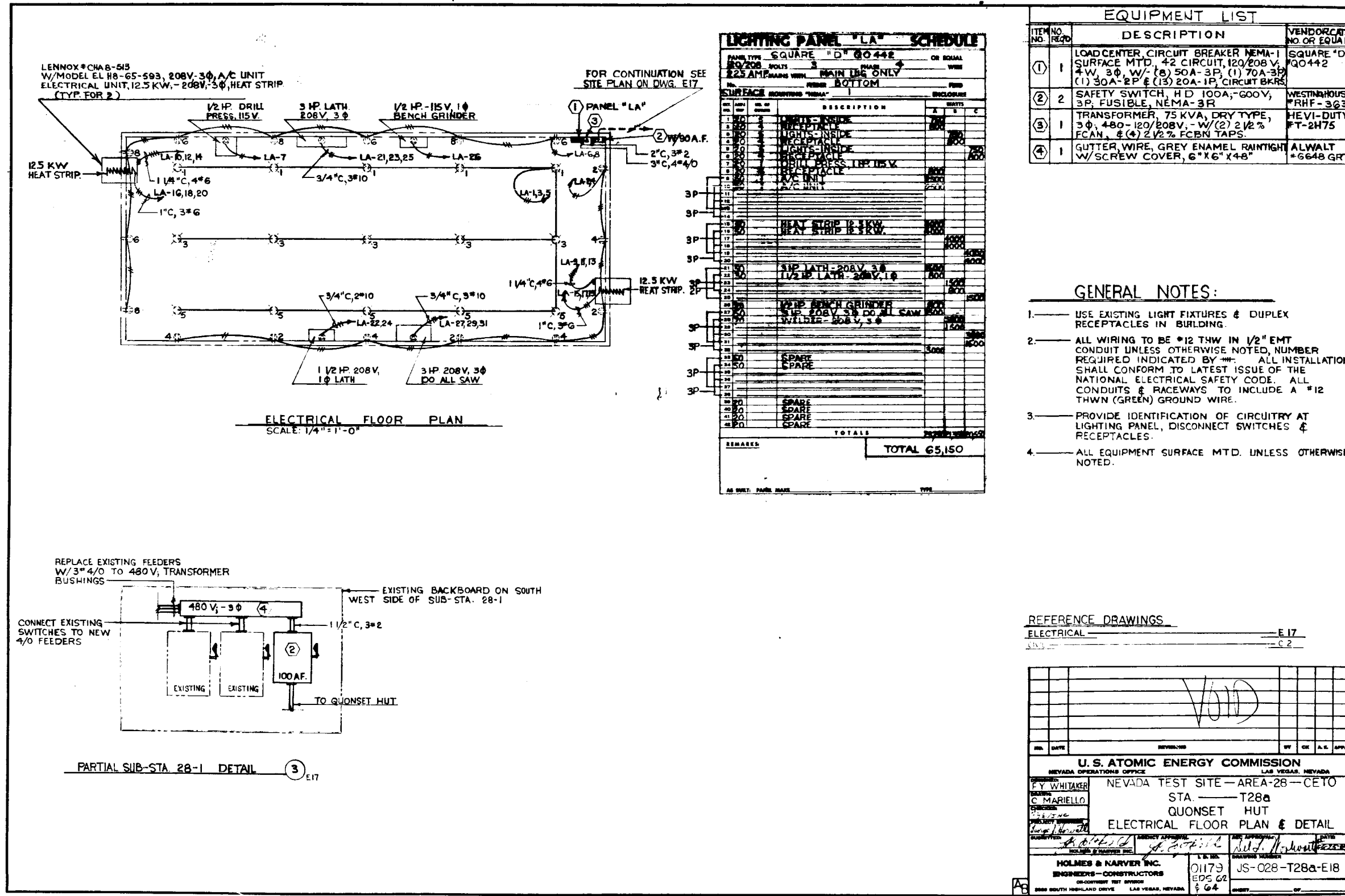

Drawing 21. Foundation floor plan and details for the Quonset Hut, Operation HENRE, Support Facilities (Holmes & Narver 1966d).

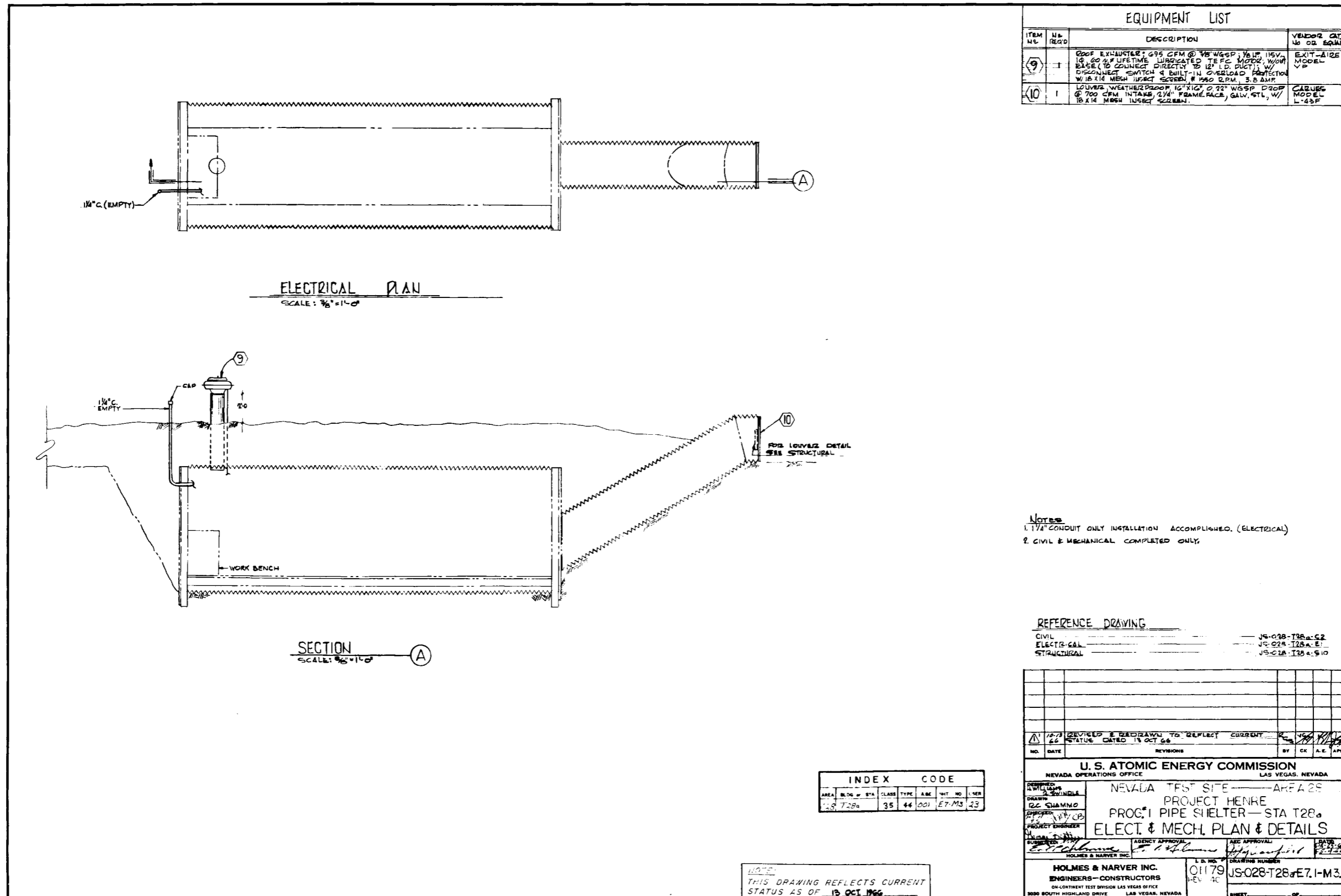

EQUIPMENT LIST			
ITEM NO.	NO. REQ'D	DESCRIPTION	VENDOR CAT. NO. OR EQUAL
9	1	ROOF EXHAUSTER: 695 CFM @ 3/8\"/>	
10	1	LOUVER: WEATHER PROOF 10\"/>	

Notes
 1. 1 1/4\"/>

REFERENCE DRAWING

CIVIL	JS-028-T28a-C2
ELECTRICAL	JS-028-T28a-E1
STRUCTURAL	JS-028-T28a-S10

INDEX CODE						
AREA	BLDG. #	STA.	CLASS	TYPE	ABC	INT. NO.
100	728a		35	44	001	E7-M3-23

NOTE
 THIS DRAWING REFLECTS CURRENT STATUS AS OF 13 OCT 1966

U. S. ATOMIC ENERGY COMMISSION NEVADA OPERATIONS OFFICE LAS VEGAS, NEVADA			
NEVADA TEST SITE - AREA 25 PROJECT HENRE PROC. 1 PIPE SHELTER - STA T28 ELECT. & MECH. PLAN & DETAILS			
DESIGNED: DRAWN: CHECKED: PROJECT ENGINEER:	AGENCY APPROVAL: HOLMES & NARVER INC.	AEC APPROVAL: DATE:	L. & N. NO. 01179 REV. 4C DRAWING NUMBER: JS-028-T28a-E7.1-M3.1 SHEET: _____ OF _____

Drawing 22. Plan and cross section for the underground civil defense shelter, Operation HENRE, Program 1 (Holmes & Narver 1966e).

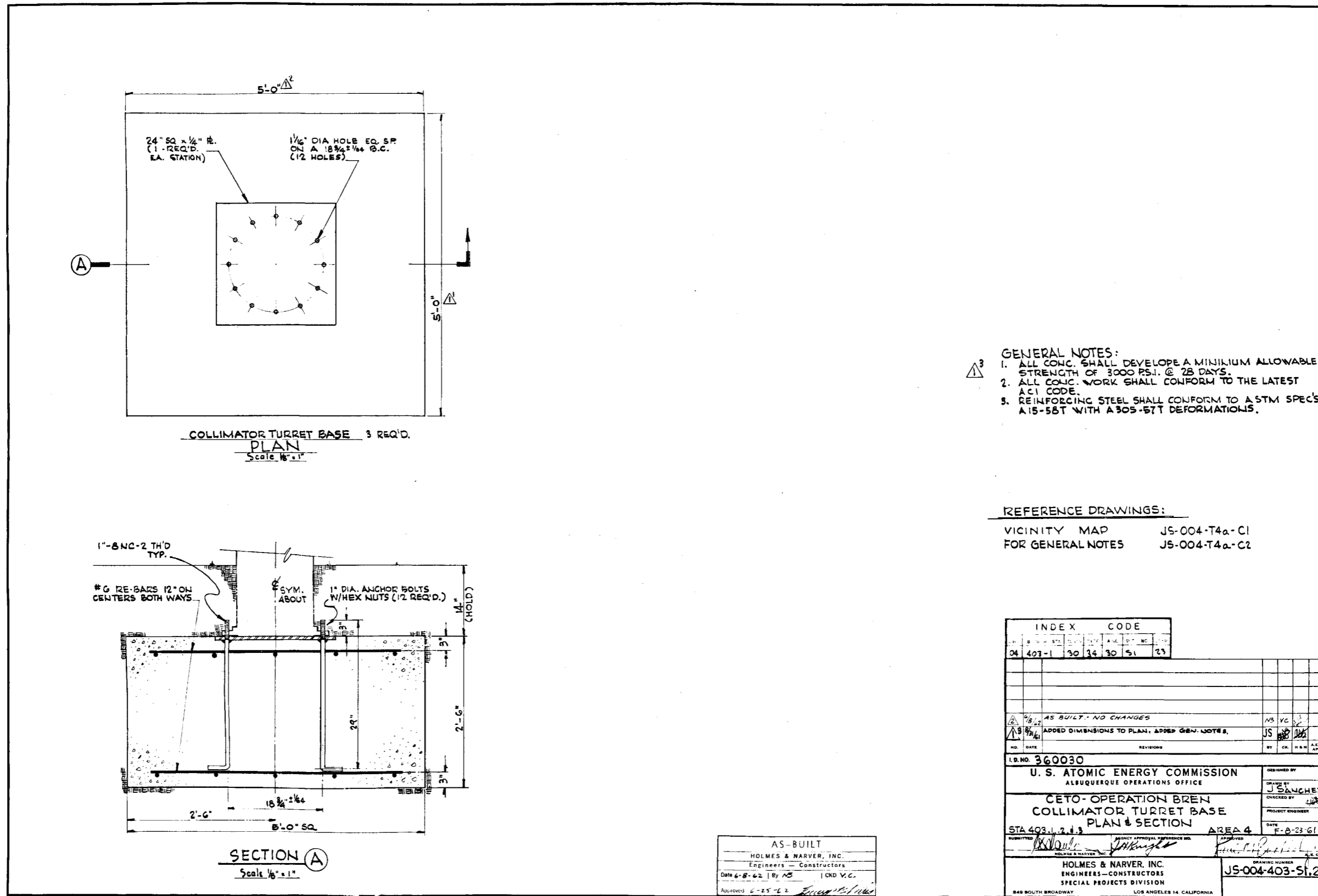

Drawing 24. Plan and sections for collimator turret base, Operation HENRE, Program 1 (Holmes & Narver 1962).

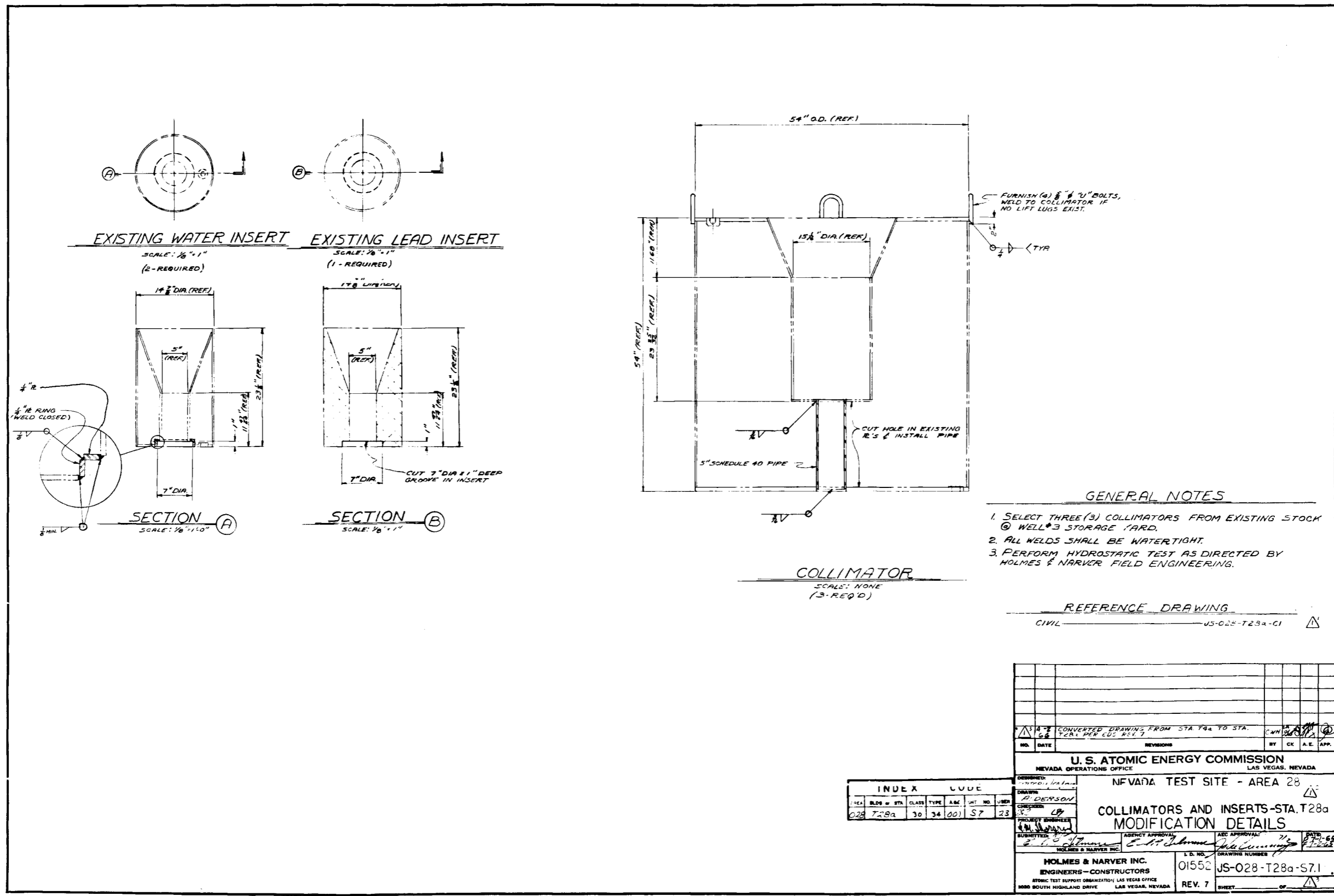

Drawing 25. Collimators and inserts, Operation HENRE, Program 1 (Holmes & Narver 1966g).

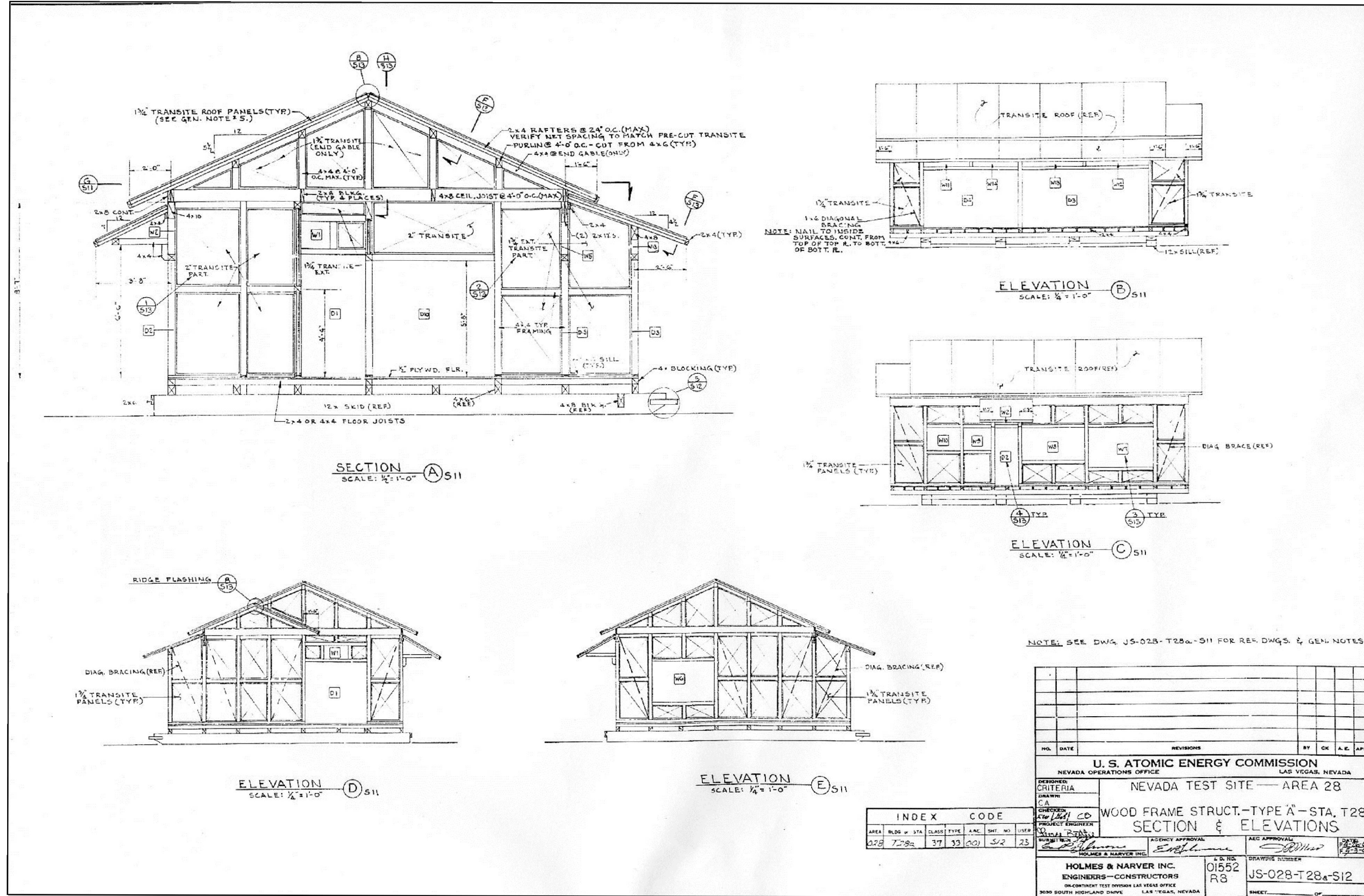

Drawing 26. Section and elevations for the analog Japanese House used for the Operation HENRE, Program 1 dosimetry experiments (Holmes and Narver 1966i).

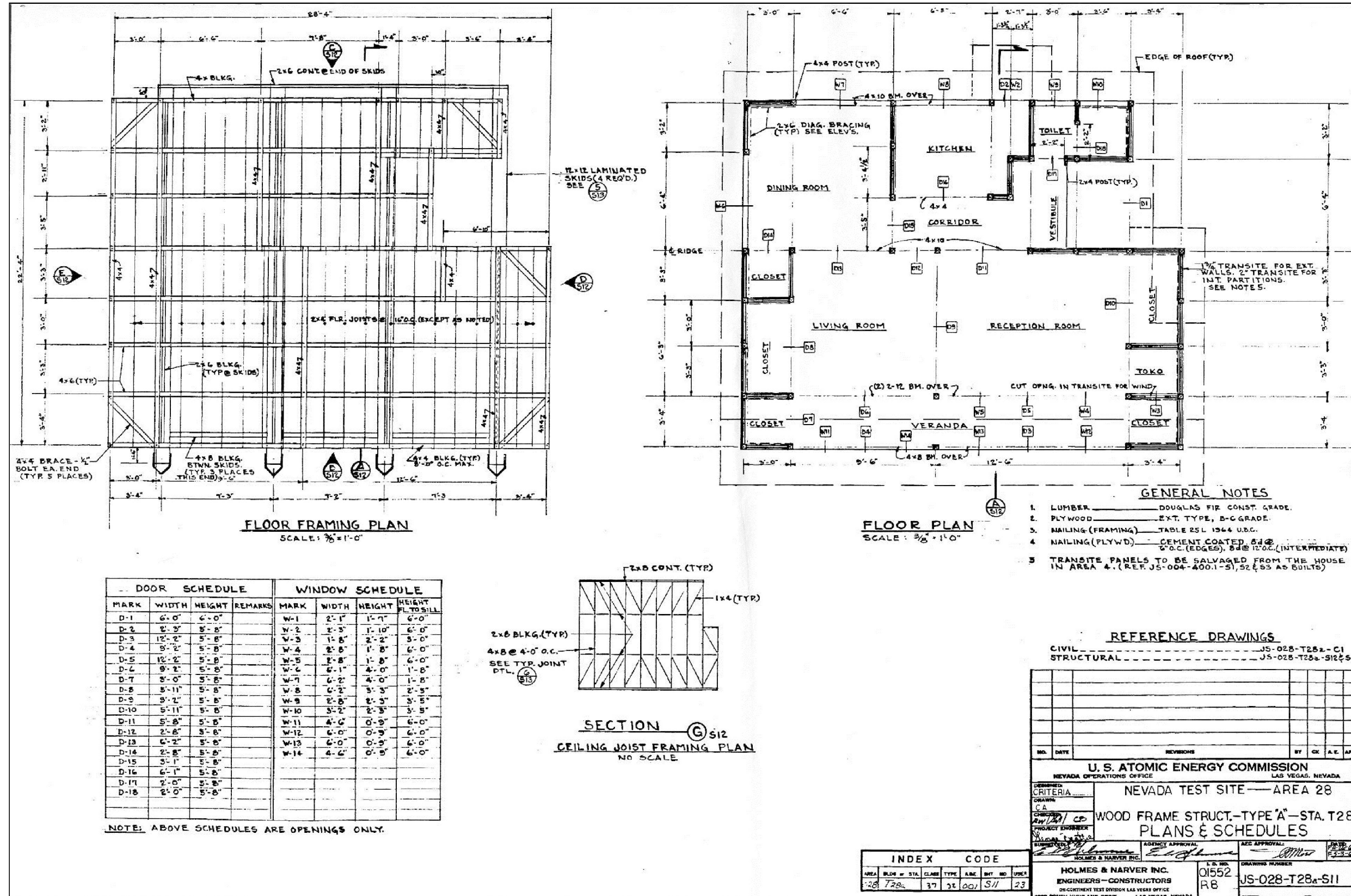

Drawing 27. Floor plan and framing schedule for the TYPE A analog Japanese House used for the Operation HENRE, Program 1 dosimetry experiments (Holmes and Narver 1966j).

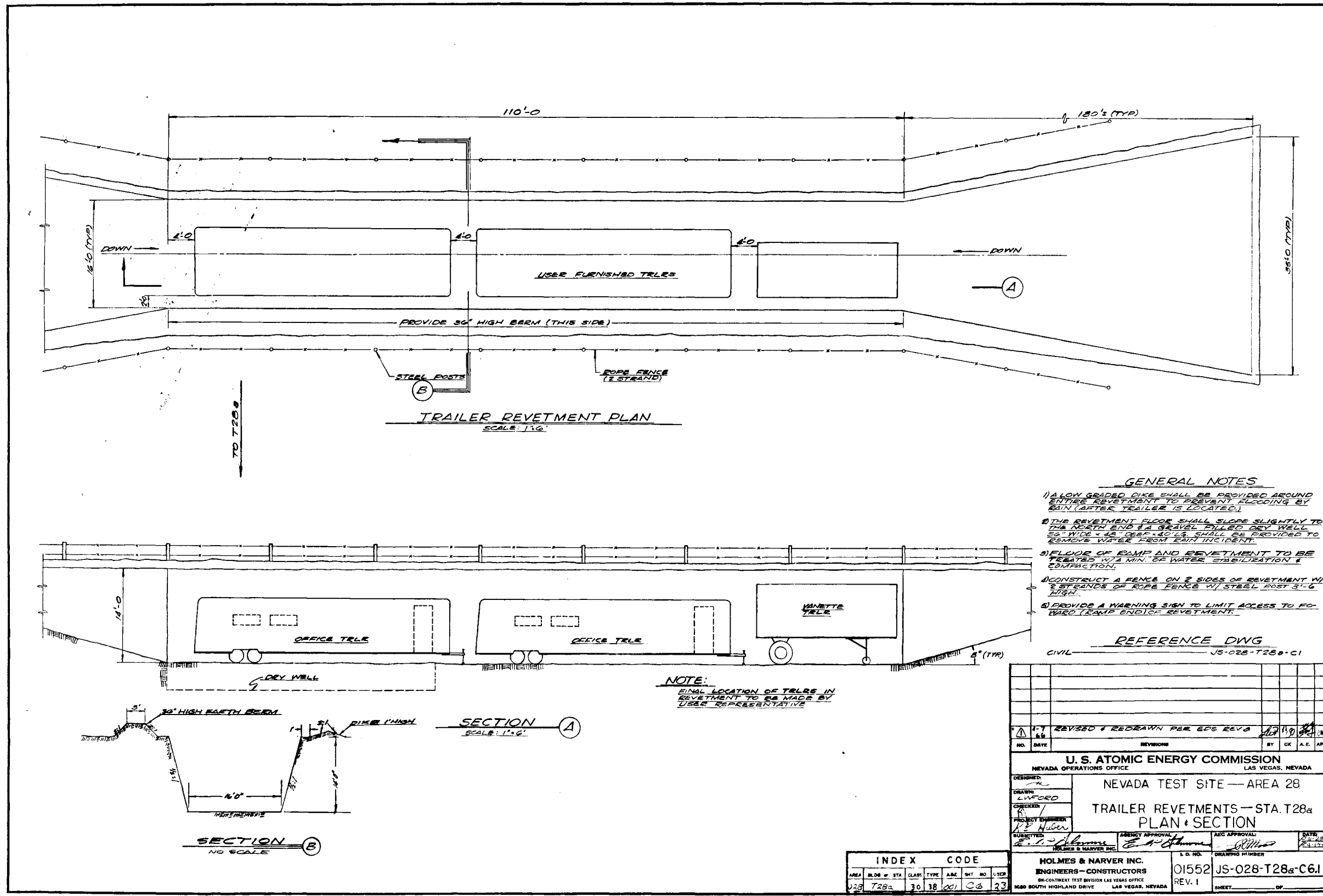

Drawing 28. Plan and section for below grade trailer revetment, Operation HENRE, Program 1 (Holmes & Narver 1966k)

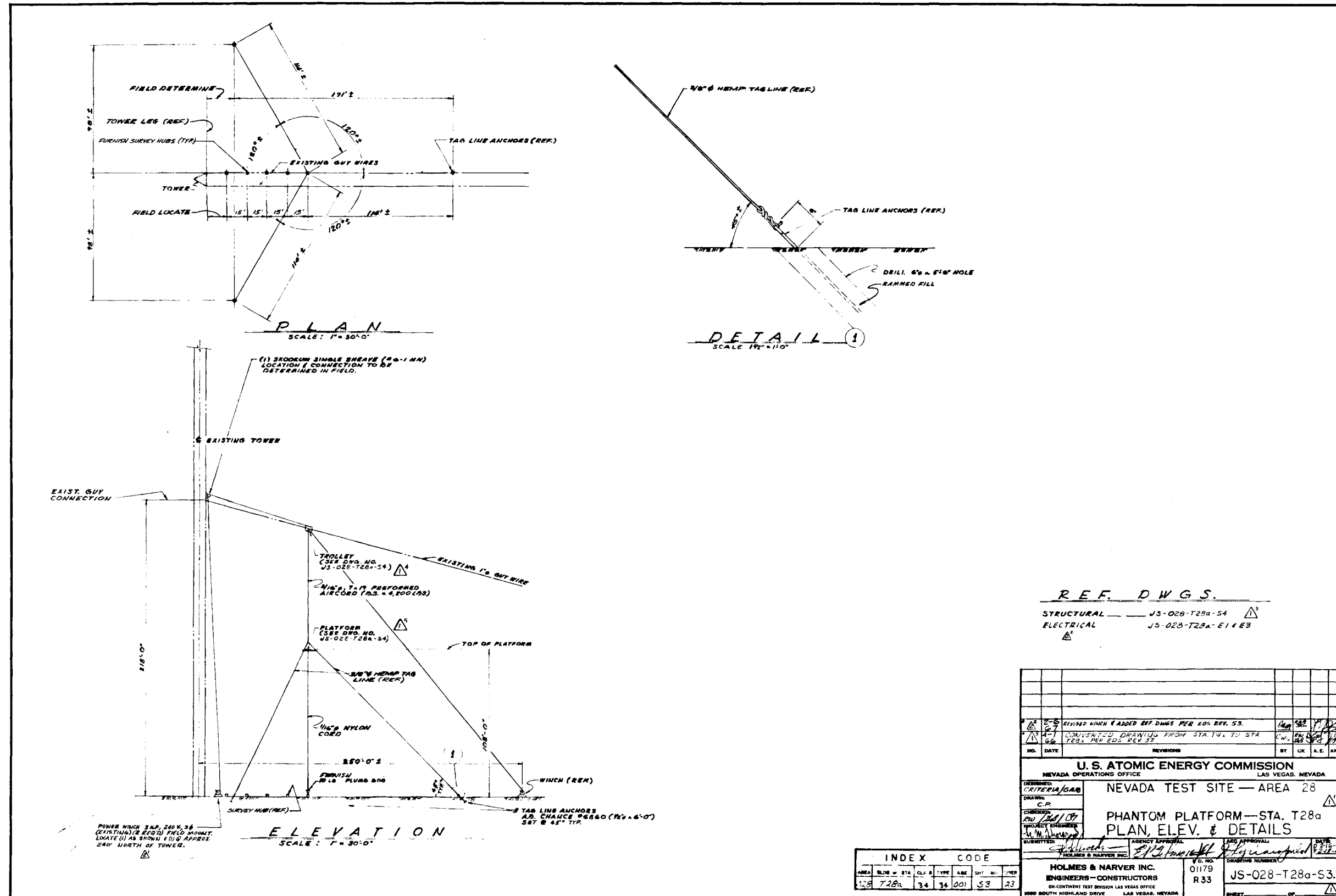

Drawing 29. Plan, elevation and details for the phantom platform, Operation HENRE Program 3 (Holmes & Narver 19661).

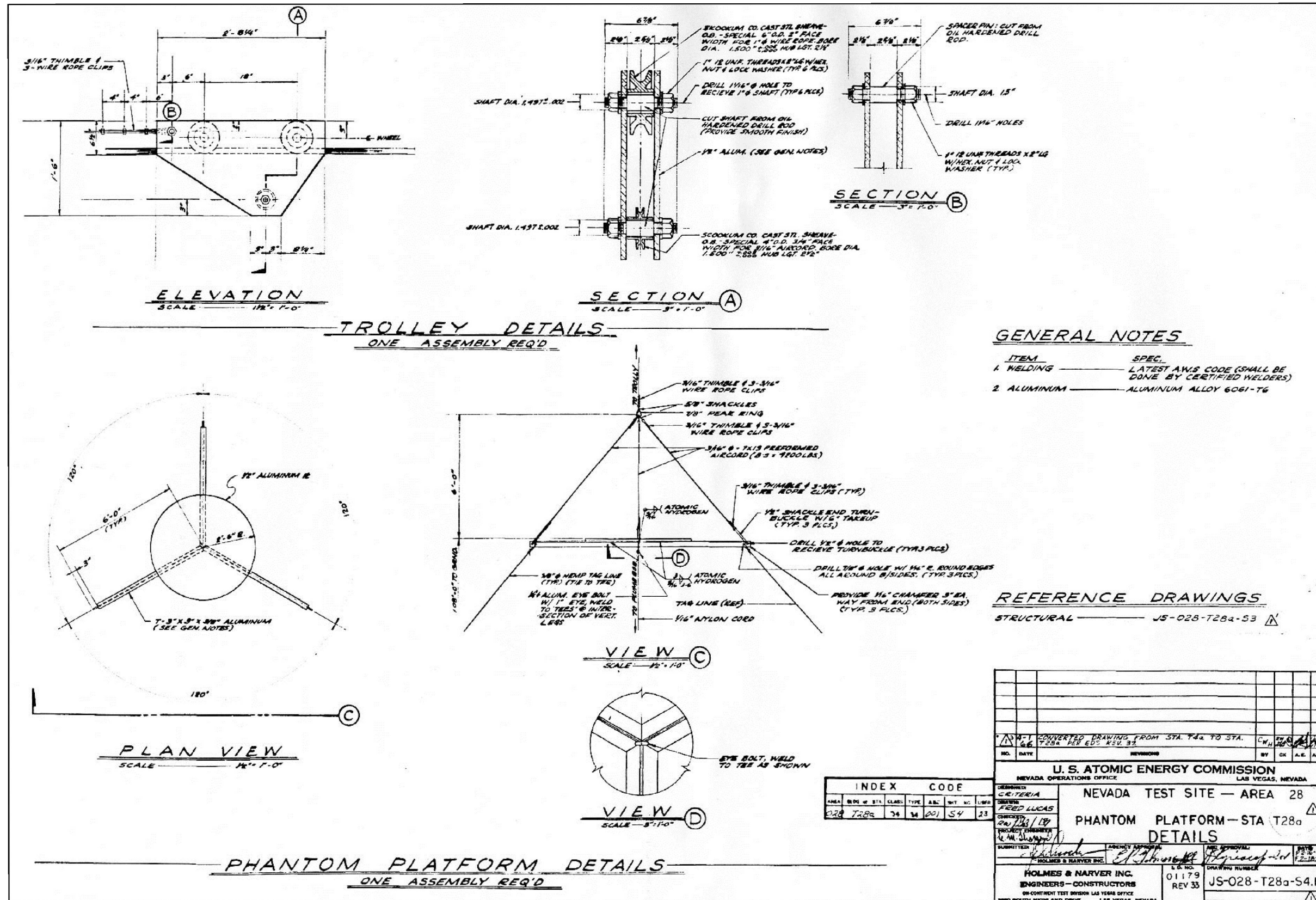

Drawing 30. Plan details for the trolley system and instrument phantom platform for some of the Operation HENRE Program 3 experiments (Holmes & Narver 1966m).

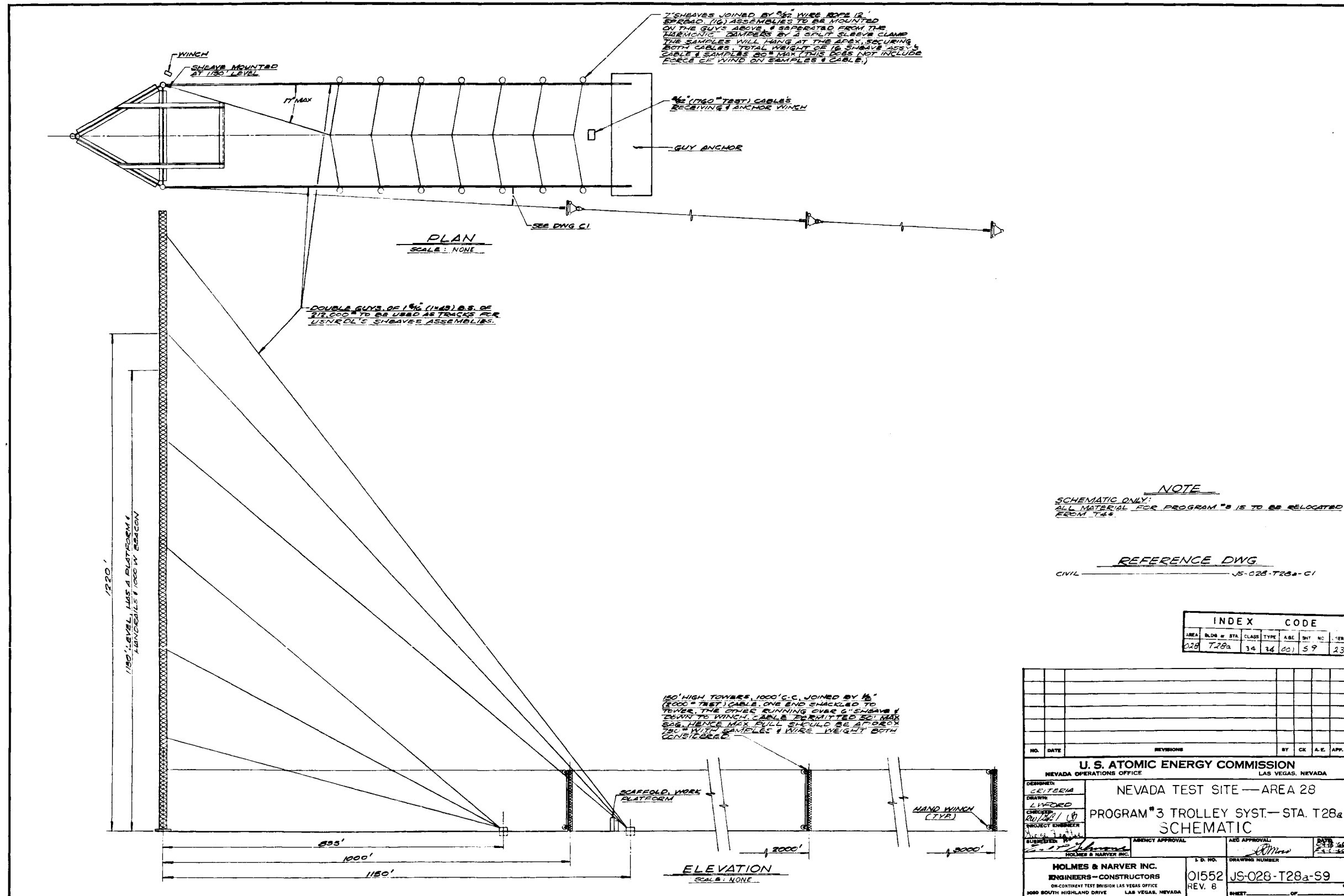

Drawing 31. Plans and cross section for the 150 ft tower trolley system, Operation HENRE Program 3 (Holmes & Narver 1966n).

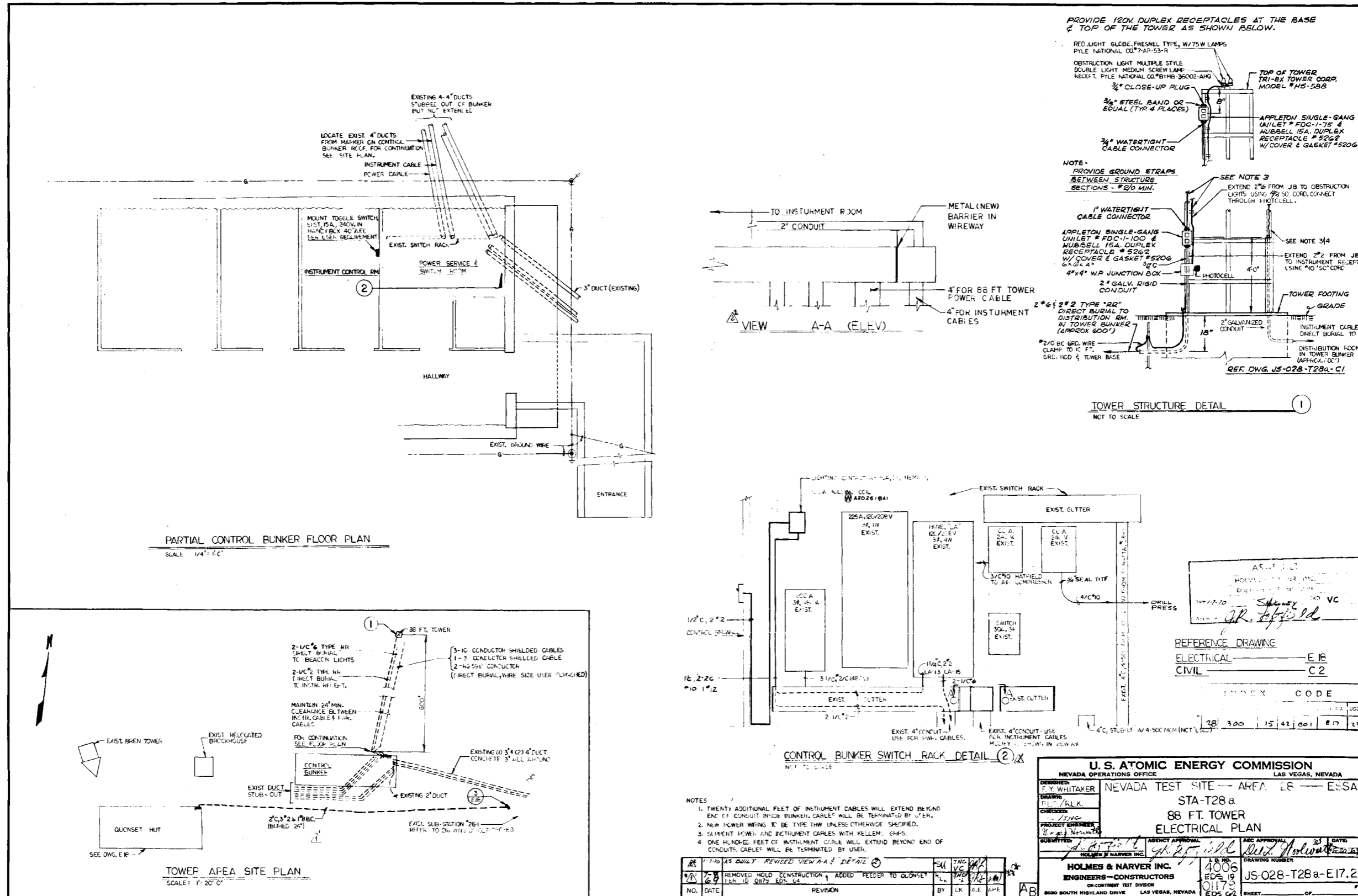

Drawing 32. Electrical plan for the 88 ft. tower, Operation HENRE Program 3 (Holmes & Narver 1969).

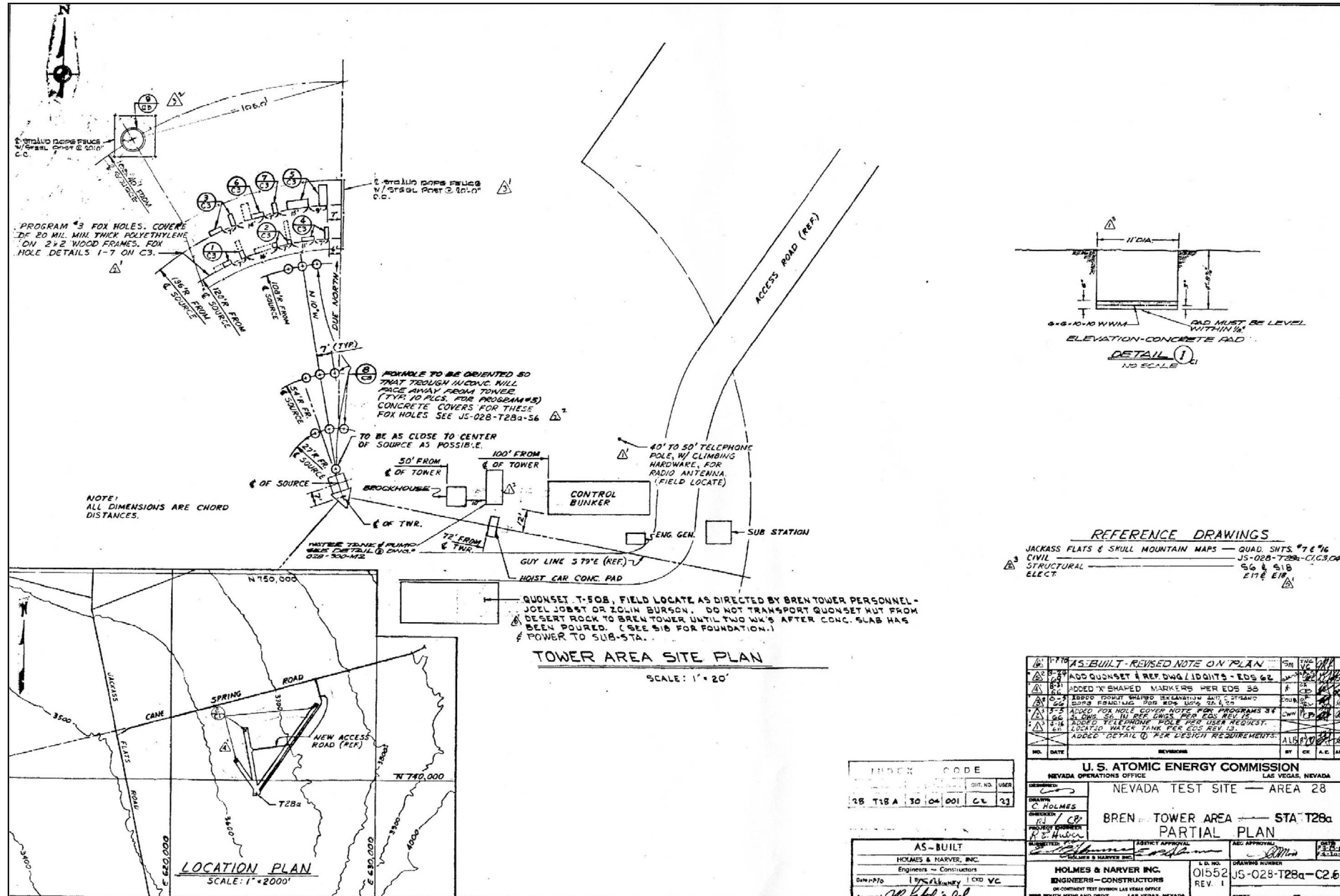

Drawing 33. Plan view for the Operation HENRE Program 3 rectangular foxholes and Program 5 cylindrical foxholes (Holmes & Narver 1966a).

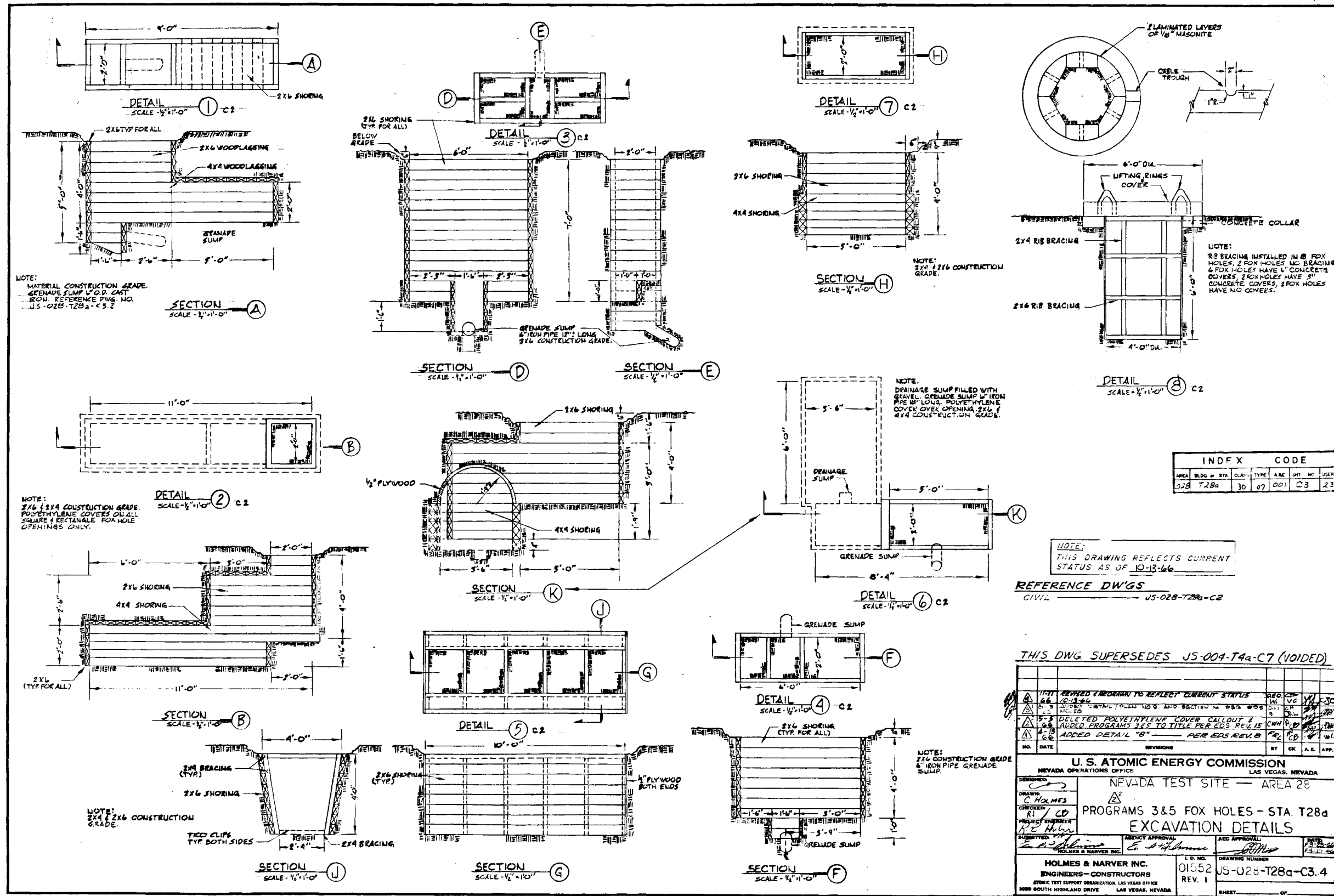

Drawing 34. Plans, cross sections and details for the Operation HENRE Program 3 rectangular foxholes and Program 5 cylindrical foxholes (Holmes & Narver 1966o).

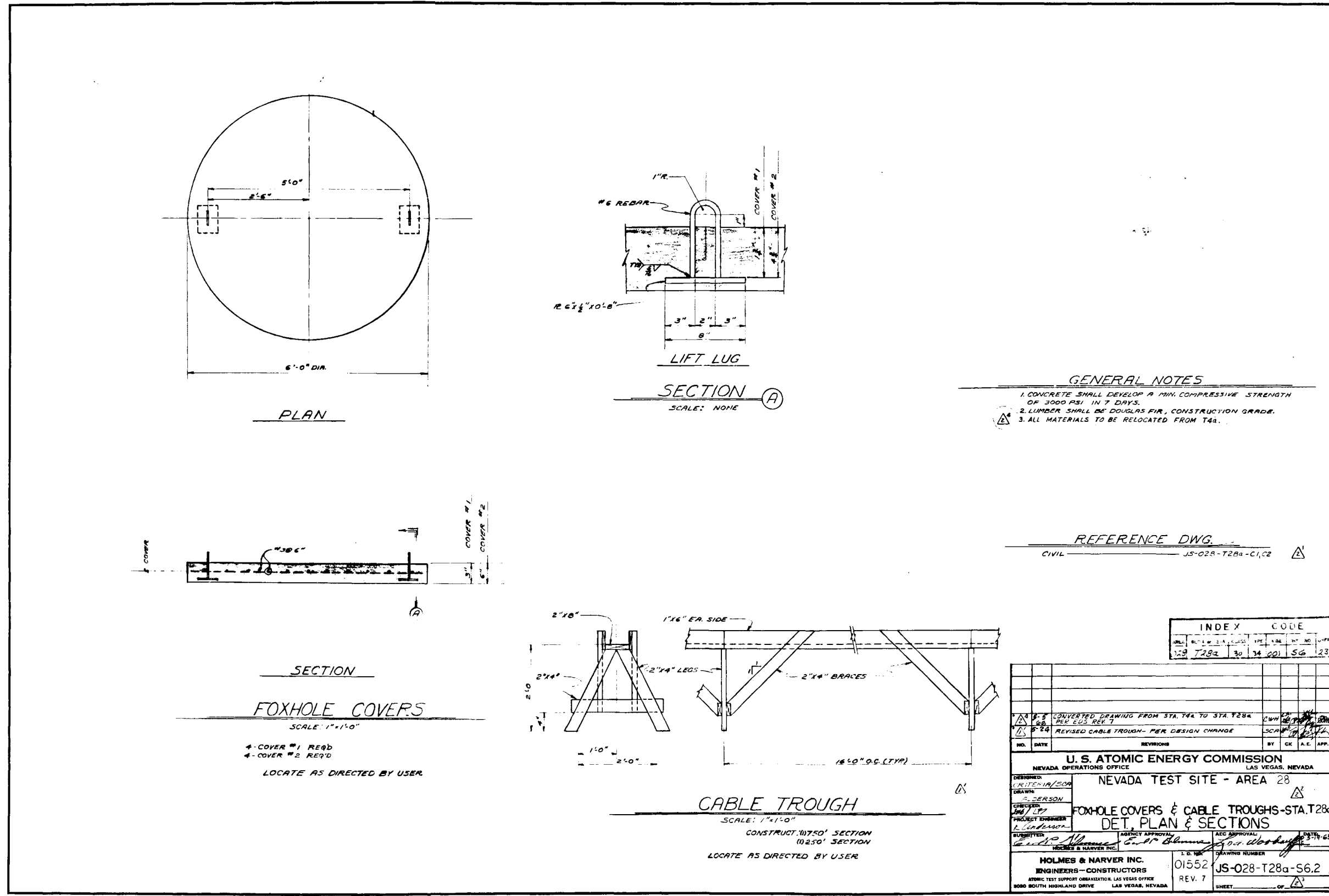

Drawing 35. Plans and cross sections for the Operation HENRE, Program 5 cylindrical foxholes and cable troughs (Holmes & Narver 1965a).

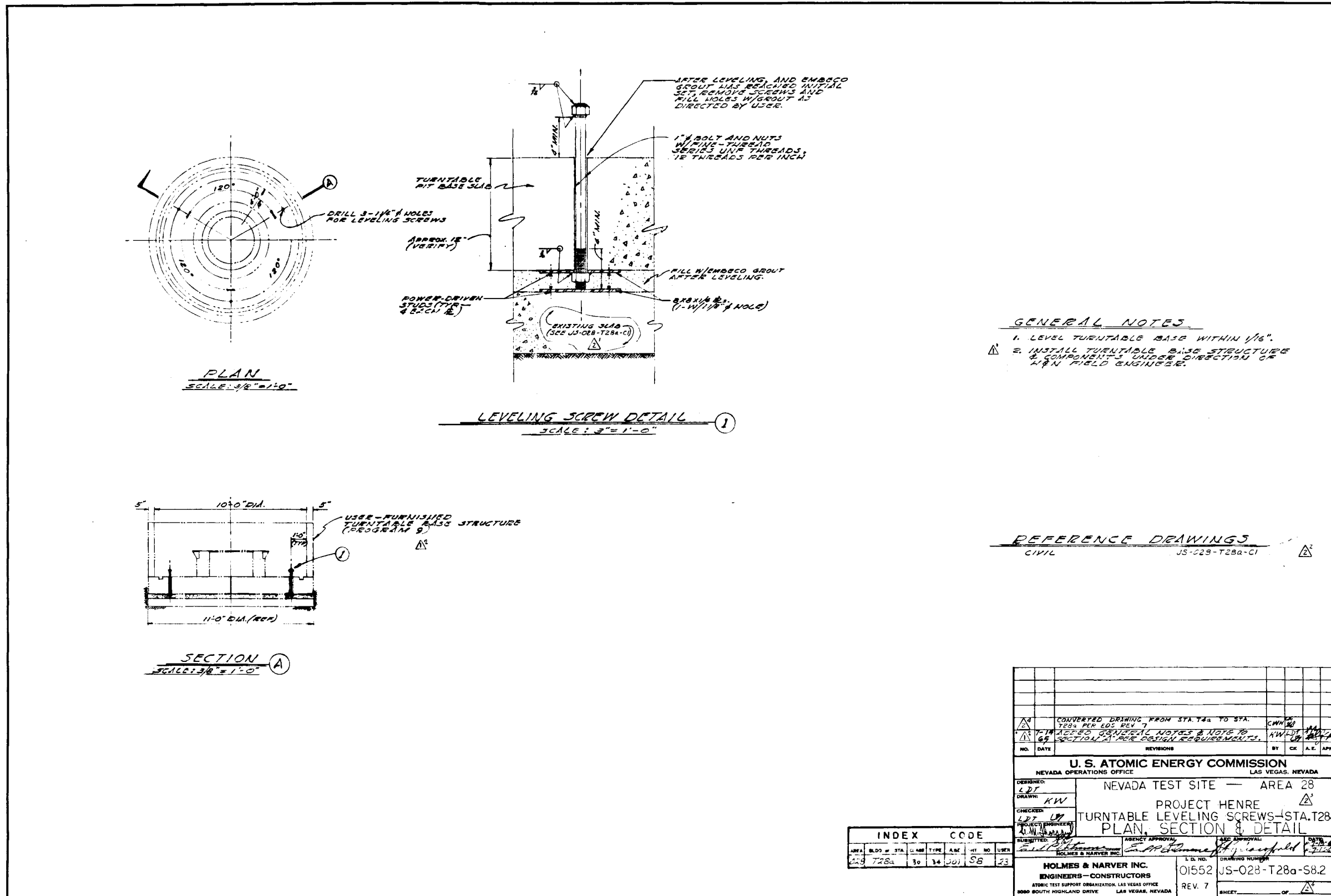

Drawing 36. Plan, cross sections, and detail for the turntable, Operation HENRE, Program 9 (Holmes & Narver 1965b).

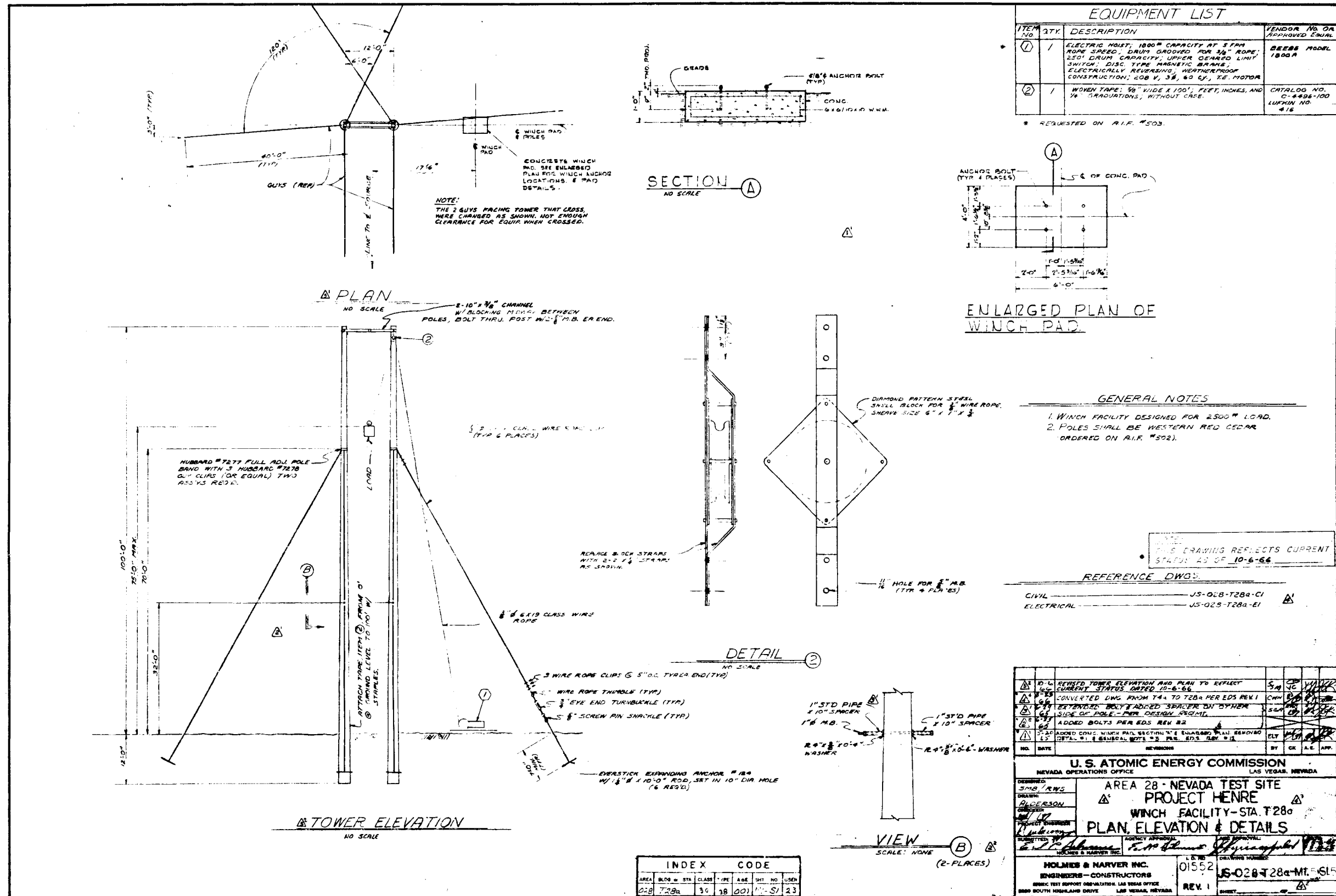

Drawing 37. Plan, elevation, and details for the wooden tower Operation HENRE, Program 9 (Holmes & Narver 1966p).

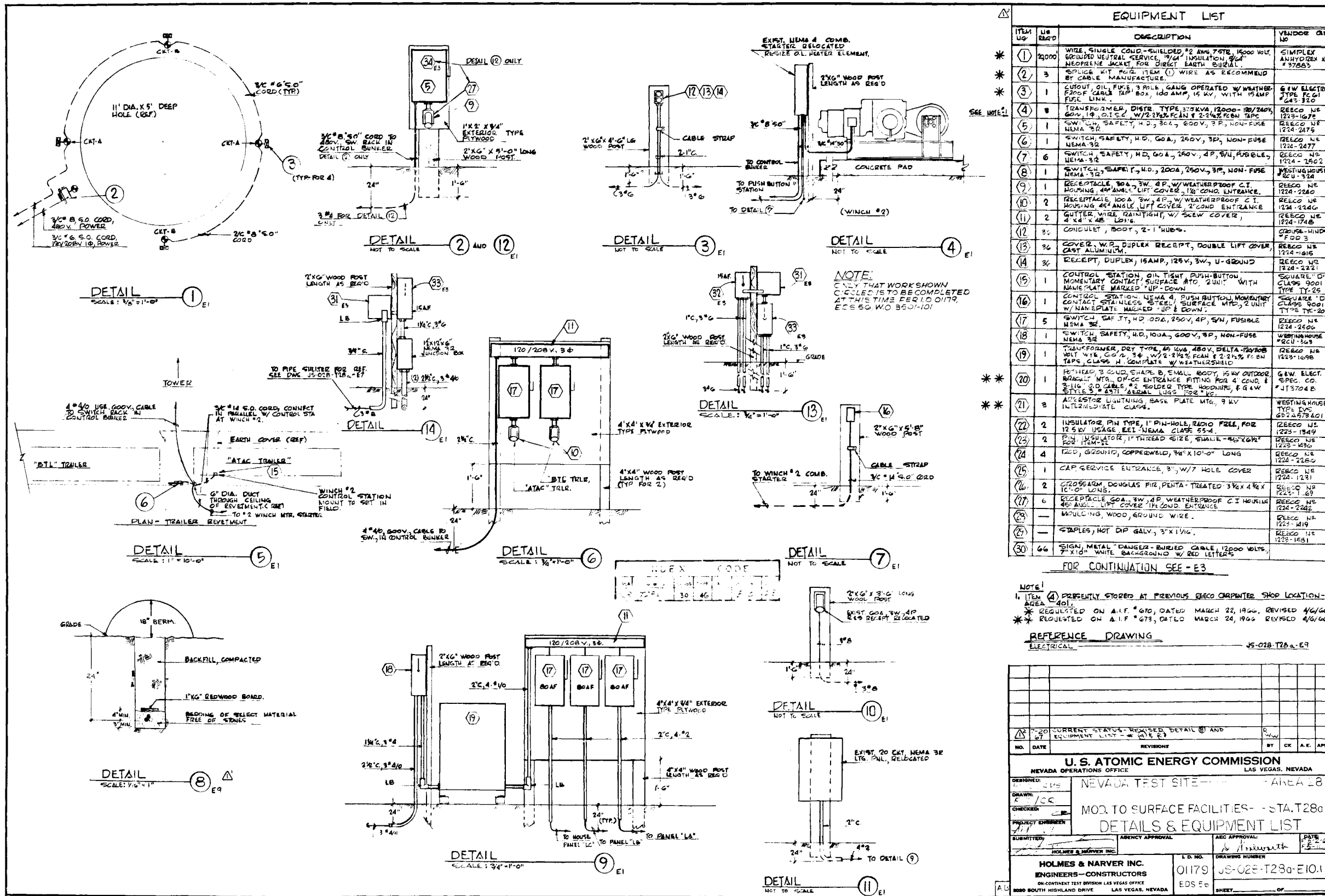

Drawing 38. Plan, elevation, and details for the some of the Operation HENRE, Program 9 surface facilities (Holmes & Narver 1967).

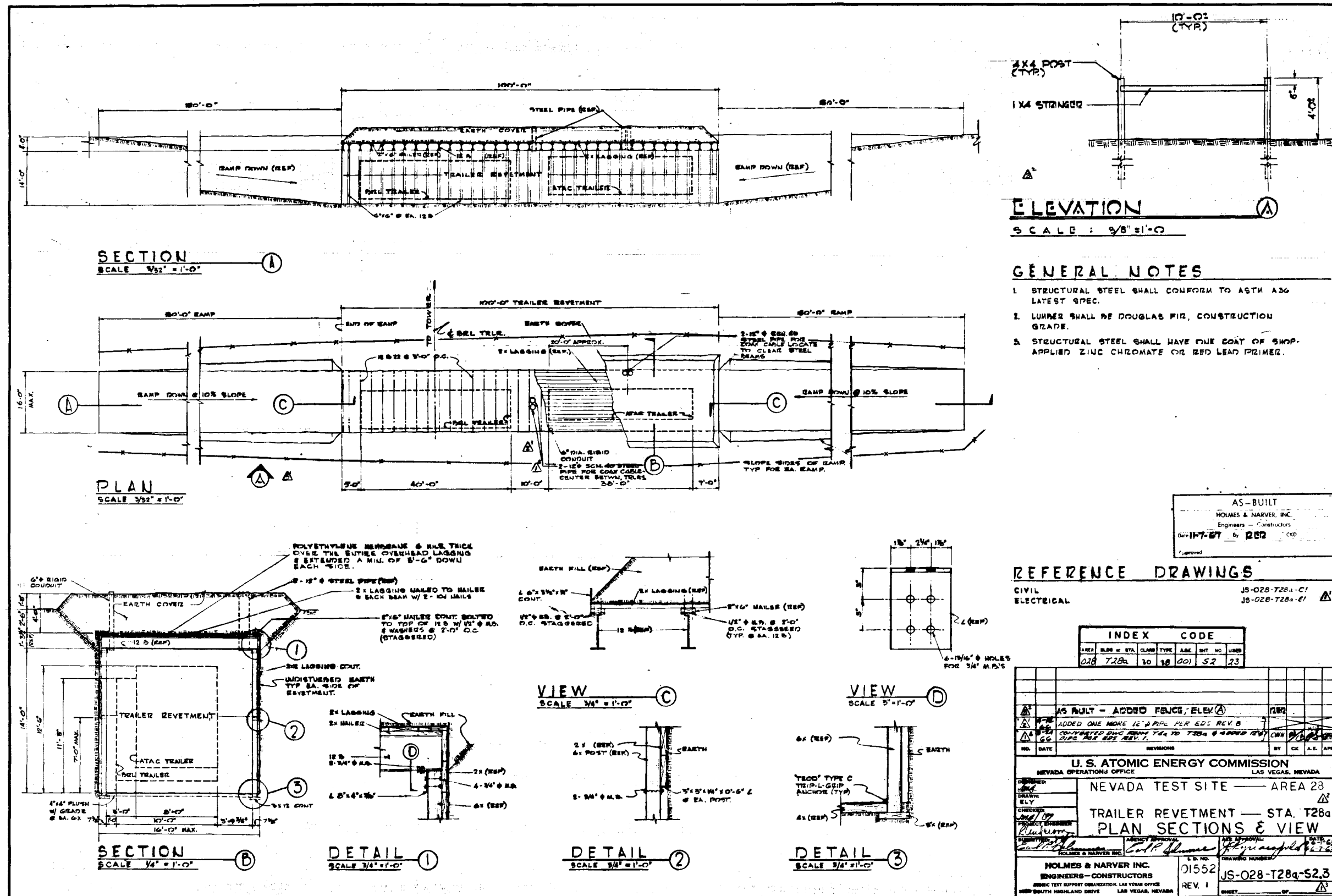

Drawing 39. Plan, cross section and view for the below grade reinforced trailer revetment, Operation HENRE, Program 9 (Holmes & Narver 1966q).

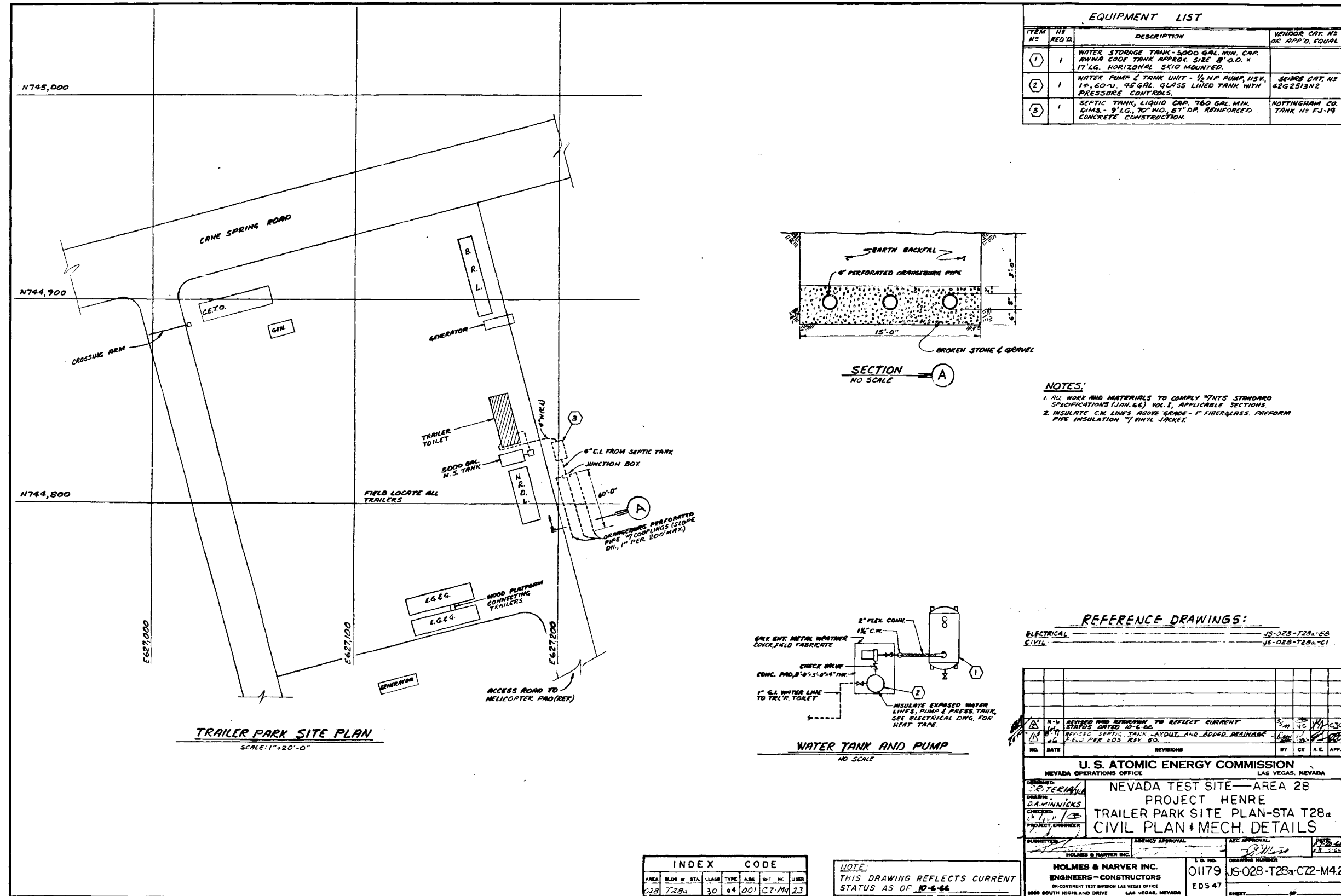

Drawing 40. Civil plan and details for remote trailer park near main gate, Operation HENRE (Holmes & Narver 1966r).

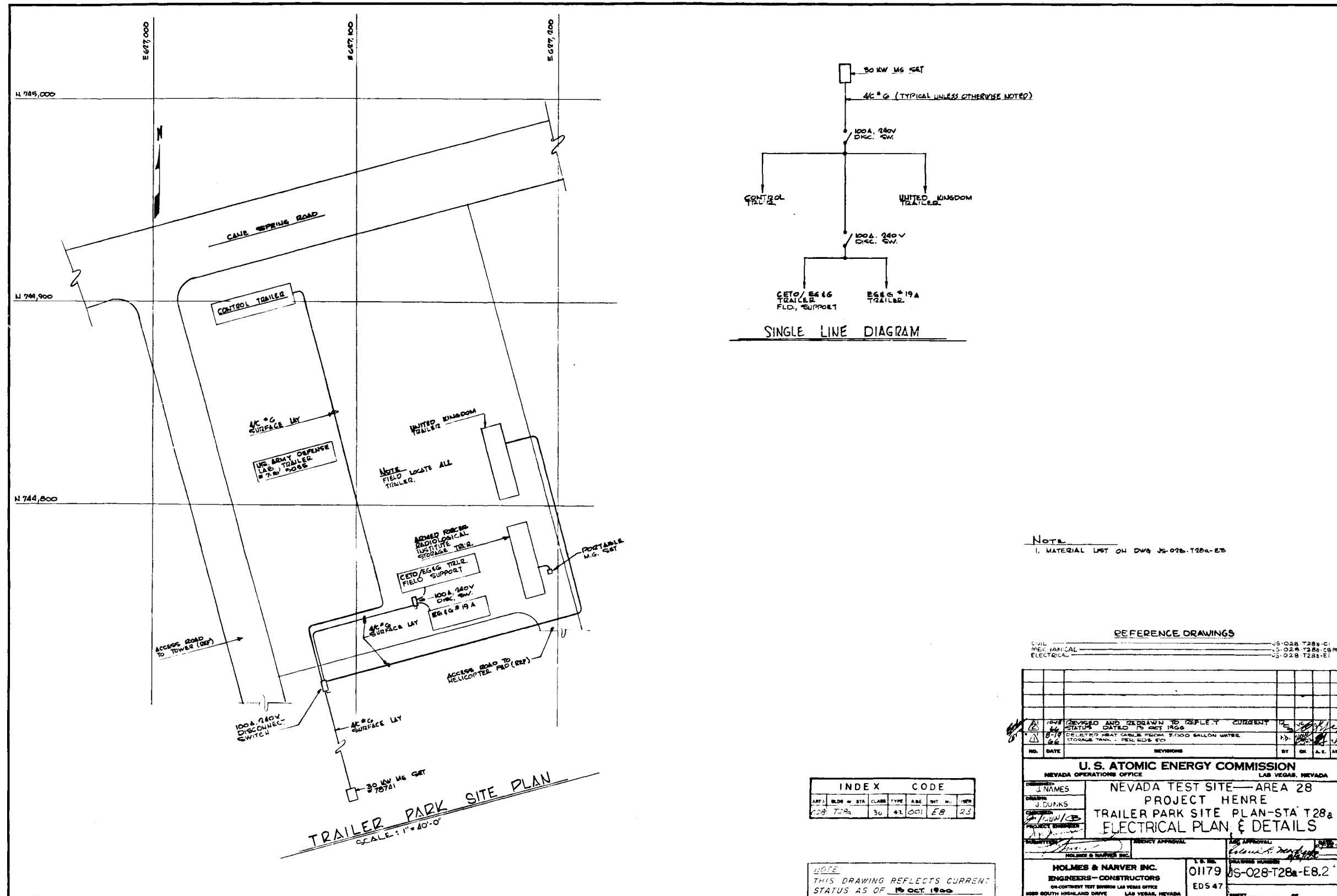

Drawing 41. Electrical plan and details for remote trailer park near main gate, Operation HENRE (Holmes & Narver 1966s).

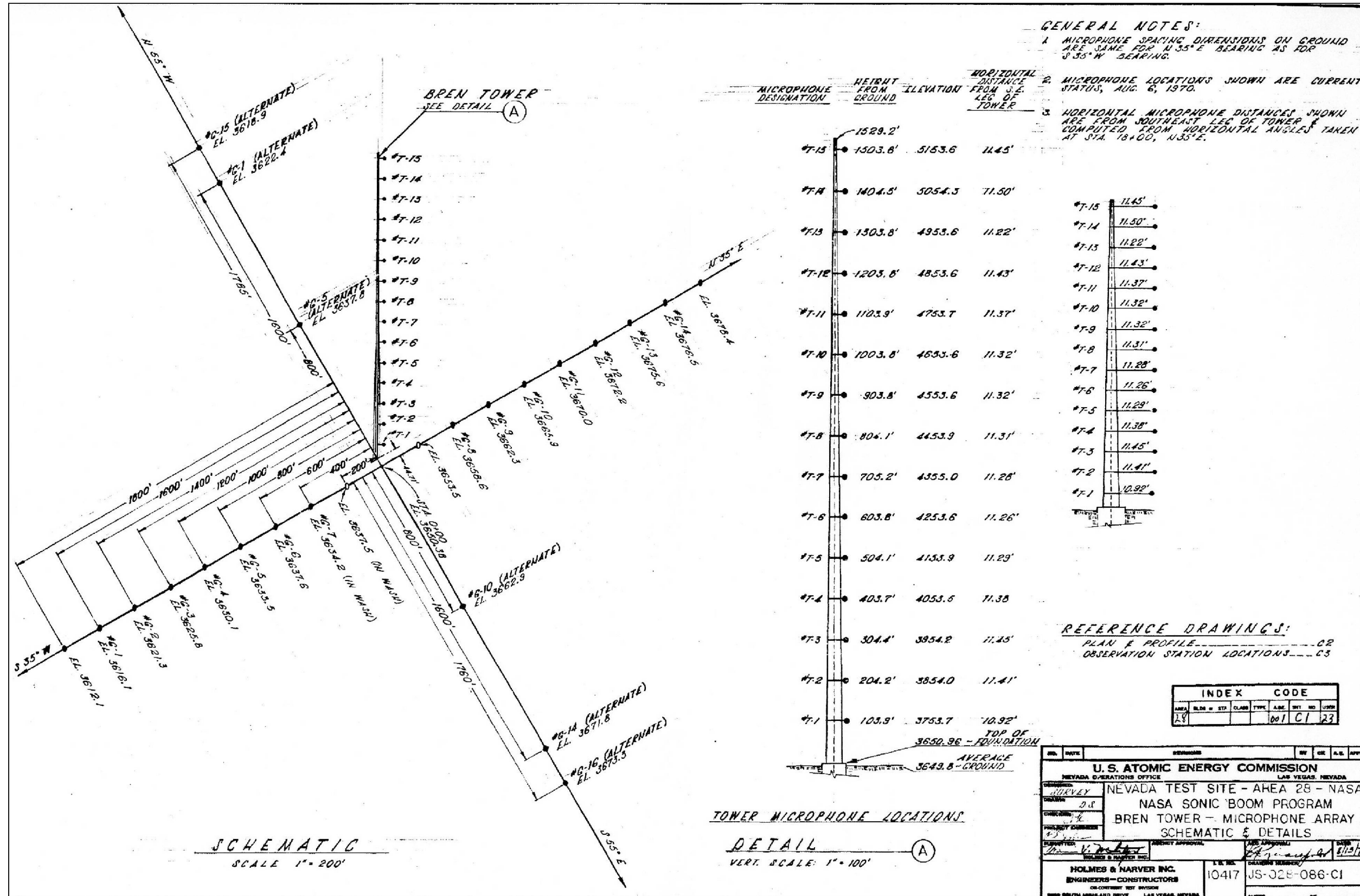

Drawing 42. Microphone array planned for the sonic boom experiments conducted at BREN Tower Complex in 1970 (Holmes & Narver 1970a).

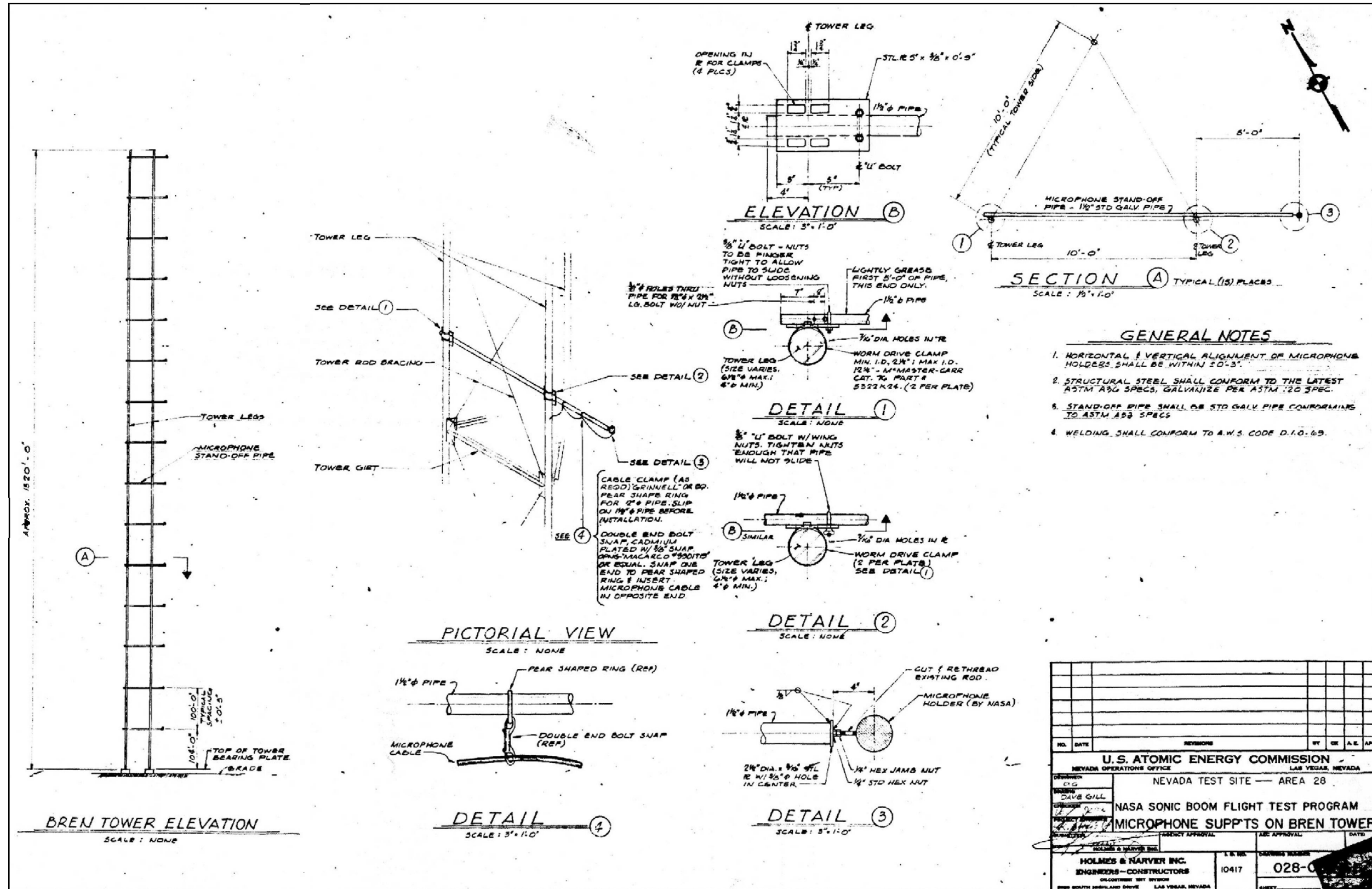

Drawing 43. Detail of microphone supports on BREN Tower for the sonic boom experiments conducted in 1970 (Holmes & Narver 1970b).



Photo 1. The newly completed foundation for BREN Tower's new location in NTS Area 25. Photo taken May 2, 1966. View is to the northwest (Photo 2241-16 on file at NNSA/NSO Nuclear Testing Archive).



Photo 2. BREN Tower being reassembled at NTS Area 25, May 12, 1966. Temporary guy wires stabilize the tower during construction. The earth mound covering the Control Bunker appears on the left behind the truck. View is to the west (Photo 2255-8 on file at NNSA/NSO Nuclear Testing Archive).



Photo 3. Orange and white painted plywood Xs were located at the ends of all three graded "runways" extending from BREN Tower. The plywood X at the north end of the central runway is in the upper right corner of this October 1967 aerial (Photo 2581-15 on file at NNSA/NSO Nuclear Testing Archive).



Photo 4. The plywood X at the north end of the central runway is enclosed by a metal T-post fence. View to west. Photo taken by DRI November 1, 2006 (on file at NNSA/NSO Curation Facility).

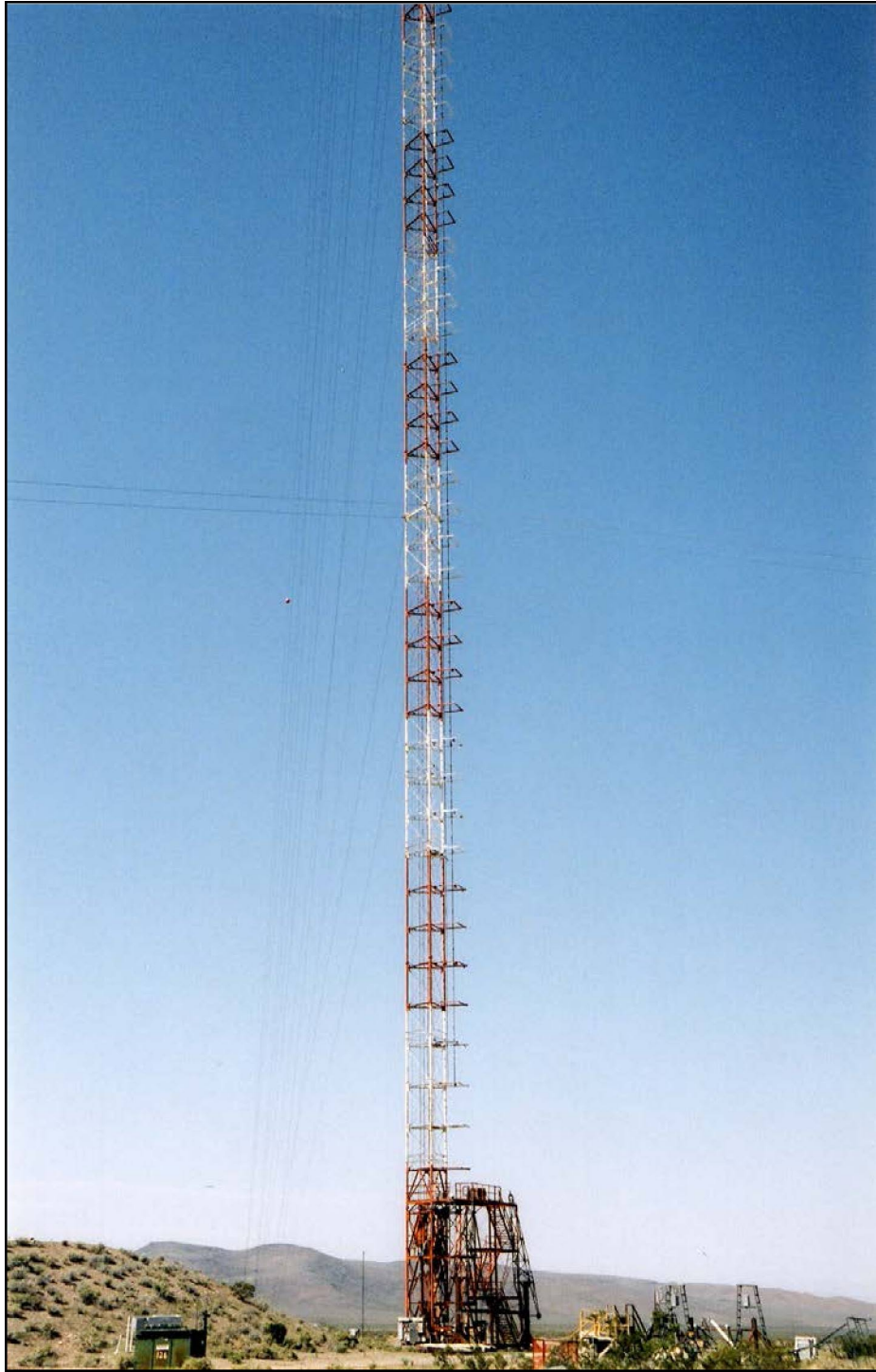

Photo 5. The BREN Tower today. Only the lower 300 ft of the tower and the main work platform are visible in this photo taken by DRI in June 2004. The Control Bunker is to the left. Discarded equipment and debris from the various experiments conducted at this location from 1966 through the mid 1990s appears at the lower right. View is to the southwest (on file at NNSA/NSO Curation Facility).



Photo 6. The upper 1,100 ft of BREN Tower in June 2004. Thirty-seven of its fifty-one 30 ft sections are visible. The faint gray lines extending from the tower are the guy wire cables that stabilize the tower. View west-southwest (on file at NNSA/NSO Curation Facility).



Photo 7. A July 10, 1967 photograph shows the lower portion of the Operation HENRE neutron accelerator mounted in the BREN Tower's payload hoist car elevator. One of the tritium targets is in place at the bottom of the accelerator assembly (Photo 2491-2 on file at NNSA/NSO Nuclear Testing Archive).



Photo 8. Detail view of one of the six pairs of stanchions that anchor the guy wires stabilizing the 1,527 ft tower. View is to the north-northeast. Photo taken by DRI in June 2004 (on file at NNSA/NSO Curation Facility).



Photo 9. Some of the discarded equipment and debris located in front (north) of BREN Tower. The base of the tower appears at the far left of the frame. View is to the west. Photo taken by DRI on November 1, 2006 (on file at NNSA/NSO Curation Facility).



Photo 10. View of the Control Bunker, Substation 28-1, and some discarded equipment. Photo taken from BREN Tower's 31-ft high main work platform, November 1, 2006. View is to the east-southeast (on file at NNSA/NSO Curation Facility).



Photo 11. A tour of the BREN Tower Complex in 1966. Visitors are entering the Operation HENRE Control Bunker. View is to the northwest (Photo 2327-11 on file at NNSA/NSO Nuclear Testing Archive).



Photo 12. Operation HENRE Control Bunker. BREN Tower and the upper portion of one of the paired 27 ft towers from the 1990s experimental program are visible behind the bunker to the left. View is to the northwest. Photo taken by DRI on November 1, 2006 (on on file at NNSA/NSO Curation Facility).



Photo 13. Interior of the Control Bunker during Operation HENRE. Fred Haywood (left), the experimental program's Technical Director, talking with project personnel. View is from the entry tunnel to the west. Photo taken October 12, 1966 (Photo 2327-12 on file at NNSA/NSO Nuclear Testing Archive).



Photo 14. Entry door leading to the interior of the Control Bunker. View is from the tunnel facing west. Photo taken by DRI in June 2004 (on file at NNSA/NSO Curation Facility).

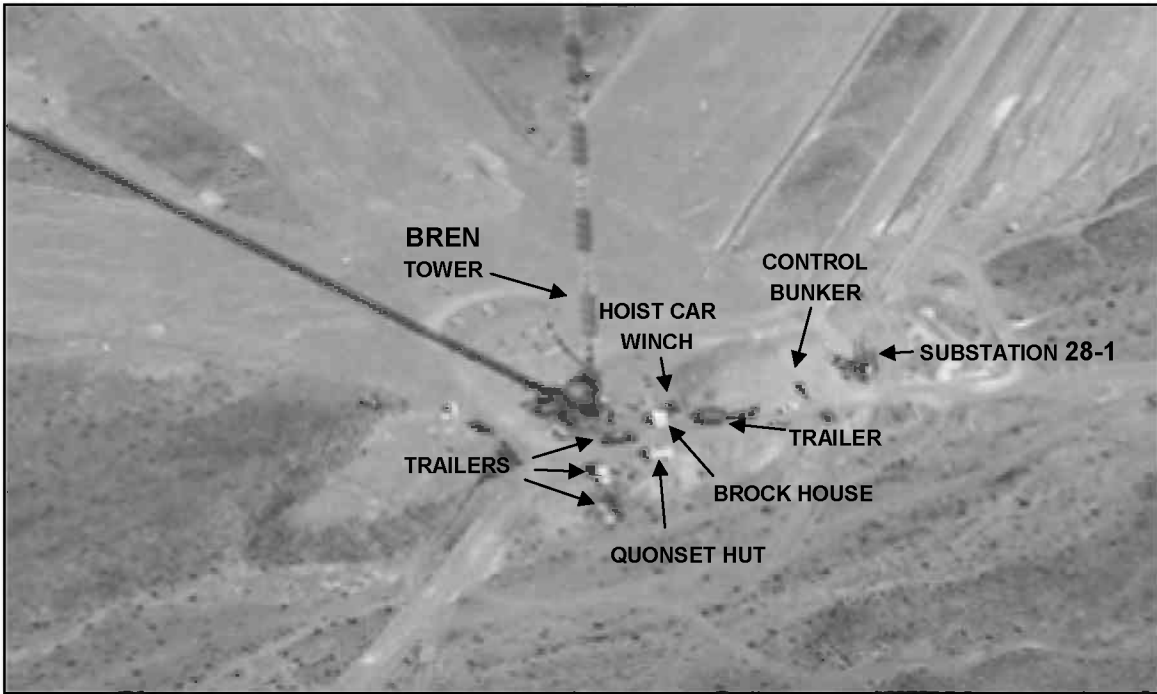

Photo 15. An October 1967 aerial of the BREN Tower Complex, showing the facilities in the immediate vicinity of the tower. View is down and to the northeast (Photo 2581-6 on file at NNSA/NSO Nuclear Testing Archive).



Photo 16. All that remains of the Quonset hut erected during Operation HENRE is the concrete foundation slab. View is west-southwest. Photo taken by DRI on November 1, 2006 (on file at NNSA/NSO Curation Facility).



Photo 17. The large winch that lifted the hoist car carrying the Operation HENRE neutron generator assembly is in the center. The brockhouse and wooden walkway to the tower were removed after HENRE ended. The photo was taken from the top of the control bunker on August 18, 1967. View is to the southwest (Photo 2530-13 on file at NNSA/NSO Nuclear Testing Archive).



Photo 18. All that remains of the hoist car winch is the foundation. The edge of the Control Bunker berm is at the top of the frame. View is to the northeast. Photo taken by DRI in June 2004 (on file at NNSA/NSO Curation Facility).



Photo 19. Overview of some of the facilities and experiments surrounding the base of BREN Tower during Operation HENRE, August 18, 1967. The winch near the Control Bunker recorded during the recent field survey (see Photo 20) does not appear in the historic Operation HENRE photos. View is to the southeast (Photo 2530-15 on file at NNSA/NSO Nuclear Testing Archive).



Photo 20. The electric winch located at the northeast corner of the Control Bunker berm is most likely associated with the “Brilliant Pebbles” experiments conducted in the early-mid 1990s rather than Operation HENRE. The winch does not appear in the 1966-1970 photographs (see Photo 19). View east-northeast. Photo taken by DRI on November 1, 2006 (on file at NNSA/NSO Curation Facility).



Photo 21. The underground civil defense shelter (aka pipe shelter) was one of the Operation HENRE Program 1 experiments. The shelter extends from the entrance on the right towards the upright ventilation pipe on the left. View to northeast. Photo taken by DRI on November 1, 2006 (on file at NNSA/NSO Curation Facility).



Photo 22. Detail of entrance to the underground civil defense shelter. Wooden door has fallen open since the June 2004 field inspection. View down and to the west. Photo taken by DRI on November 1, 2006 (on file at NNSA/NSO Curation Facility).



Photo 23. Cable trough leading from the underground civil defense shelter ventilation pipe toward the Control Bunker. View is to the south-southwest. Photo taken by DRI on November 1, 2006 (on file at NNSA/NSO Curation Facility).



Photo 24. Standard collimator located at 450 ft from BREN Tower. The opening of the collimator is facing southeast. The collimator was used during the Operation HENRE Program 1 dosimetry studies. The Program 9 wooden tower appears in the background. View is to the northwest. Photo taken by DRI on November 1, 2006 (on file at NNSA/NSO Curation Facility).



Photo 25. Mobile weather station located 607 ft from BREN Tower. The station consists of an extendable mast with an anemometer, wind direction indicator, and telemetry equipment. The mobile unit positioned alongside the mast included instrumentation to record temperature, barometric pressure, humidity, and precipitation. View to northeast. Photo taken by DRI on November 1, 2006 (on file at NNSA/NSO Curation Facility).



Photo 26. Mobile tower located approximately 1,000 ft from BREN Tower. This tower is probably associated with one of the post-1970 experimental programs conducted at the BREN Tower Complex. View to east. Photo taken by DRI on November 1, 2006 (on file at NNSA/NSO Curation Facility).

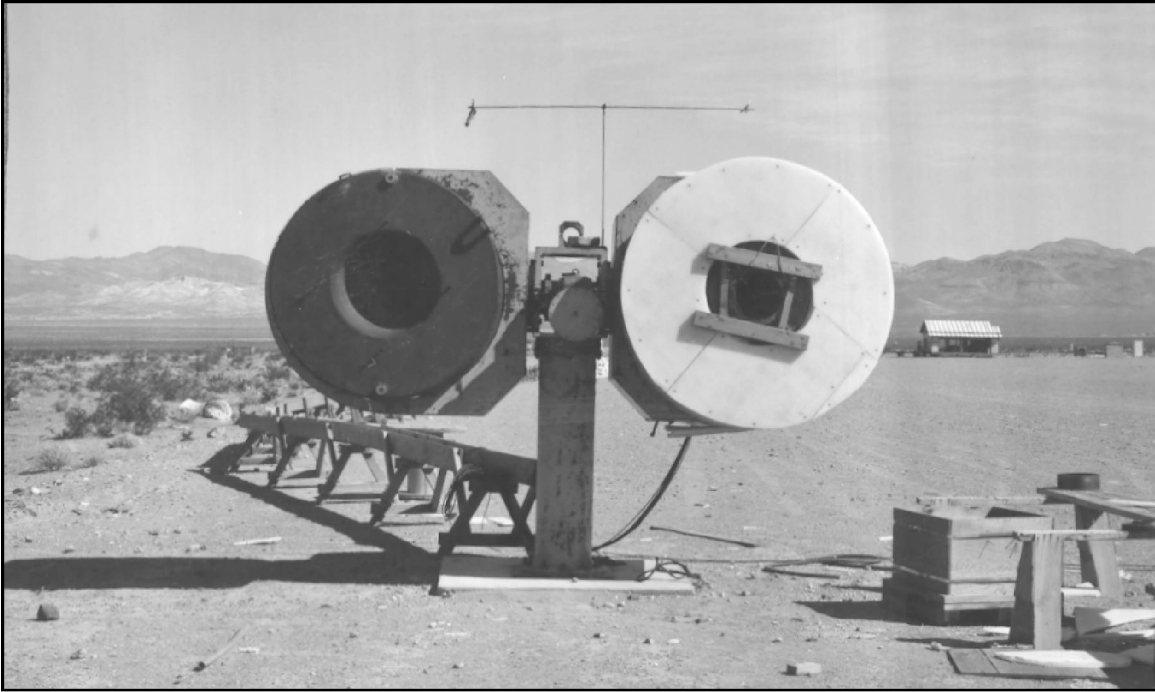

Photo 27. Turret-mounted collimators located 1,500 ft from BREN Tower. View is to the north. Photo taken during Operation HENRE, August 3, 1967 (Photo 2516-13 on file at NNSA/NSO Nuclear Testing Archive).



Photo 28. Turreted-mounted collimators located 1,500 ft from BREN Tower. View is to the north. Photo taken by DRI on November 1, 2006 (on file at NNSA/NSO Curation Facility).



Photo 29. August 1967 photograph of the eastern member of a pair of partially buried collimators located 1,520 ft from BREN Tower. (Photo 2516-10 on file at NNSA/NSO Nuclear Testing Archive).



Photo 30. The pair of partially buried collimators located 1,520 ft from BREN Tower. The opening of the western collimator is oriented straight up, while the eastern collimator is oriented toward the tower. A Program 3 150-ft tower is visible in the background. View is to the east-southeast. Photo taken by DRI on November 1, 2006 (on file at NNSA/NSO Curation Facility).



Photo 31. Buried collimator located 1,800 ft from BREN Tower. The surface facing BREN Tower is covered with sandbags, while the collimator body has been covered with earth. August 1967 (Photo 2516-7 on file at NNSA/NSO Nuclear Testing Archive).



Photo 32. This is the same collimator shown in Photo 31 in November 2006. The sandbags are gone and some of the earth covering the body of the collimator has eroded. View is to the northeast (on file at NNSA/NSO Curation Facility).



Photo 33. Row of 10 collimators at 1,800 ft from BREN Tower. The raised earth berm and bladed path are clearly visible. Photo taken during Operation HENRE, August 1967. View is east-southeast (Photo 2516-4 on file at NNSA/NSO Nuclear Testing Archive).



Photo 34. Row of 10 collimators at 1,800 ft from BREN Tower. Collimator No. 1 is on the right and No. 10 is at the far left. View is to the southeast. Photo taken by DRI on November 1, 2006 (on file at NNSA/NSO Curation Facility).

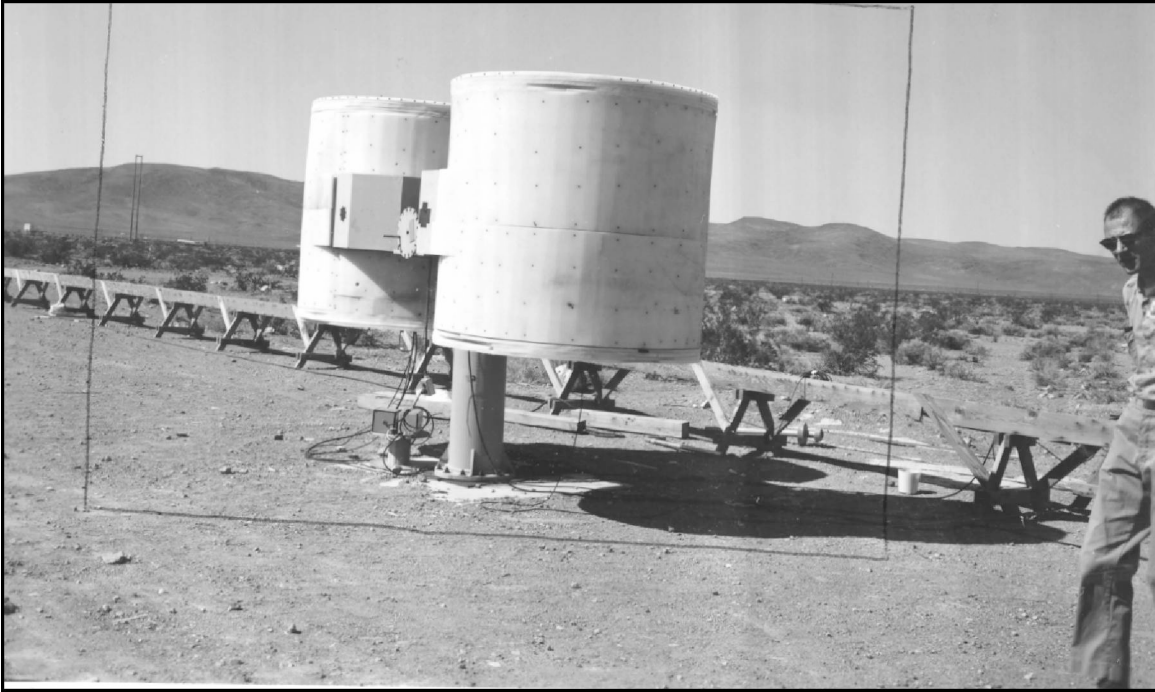

Photo 35. Pair of turret-mounted collimators located 2,250 ft from BREN Tower as part of Experimental Program 1, Operation HENRE, August 3, 1967. View is to the south-southwest (Photo 2518-4 on file at NNSA/NSO Nuclear Testing Archive).



Photo 36. This instrument tower for a later (post-1970) experiment was erected on the former location of the turret-mounted collimators shown in Photo 35. View is to the northwest. Photo taken by DRI on November 1, 2006 (on file at NNSA/NSO Curation Facility).



Photo 37. August 1967 photograph of the pair of platform mounted collimators located at 2,250 ft from BREN Tower. A pair of the insulated turret-mounted collimators is in the background at the left and the corner of an Oak Ridge National Laboratory Radiation Dosimetry Health Physics Division support trailer appears on the right. View is to the northwest (Photo 2518-5 on file at NNSA/NSO Nuclear Testing Archive).



Photo 38. The same pair of platform mounted collimators in June 2004. The pair of turret-mounted collimators shown in Photo 35 was replaced by the metal instrument tower to the left. View is to northwest (on file at NNSA/NSO Curation Facility).



Photo 39. North elevation of the analog Japanese House in 1967. The fenced instrument trailer revetment is visible in the foreground and the two concrete prisms used in the dosimetry studies sit to the right (west) of the house. View is to the south (Photo 2307-8 on file at NNSA/NSO Nuclear Testing Archive).



Photo 40. East and north elevations of the analog Japanese House in November 2006. Windows and doorway have been boarded over. View to the southwest (on file at NNSA/NSO Curation Facility).



Photo 41. South and east elevations of the analog Japanese House in 1967. Wooden cable troughs for the dosimetry instrumentation are visible on both sides of the house. The fence surrounding the trailer revetment is in the background. View is to the northwest (Photo 2515-14 on file at NNSA/NSO Nuclear Testing Archive).



Photo 42. West and south elevations of the analog Japanese House in November 2006. View is to the northeast (on file at NNSA/NSO Curation Facility).



Photo 43. North elevation and interior of the analog Japanese House, August 3, 1967. Photo taken looking north through the veranda, across the living/reception rooms, and out the dining room and kitchen windows (Photo 2515-12 on file at NNSA/NSO Nuclear Testing Archive).



Photo 44. Interior view of the analog Japanese House taken from the southeast corner of the veranda. View is to the northeast. Photo taken by DRI in June 2004 (on file at NNSA/NSO Curation Facility).

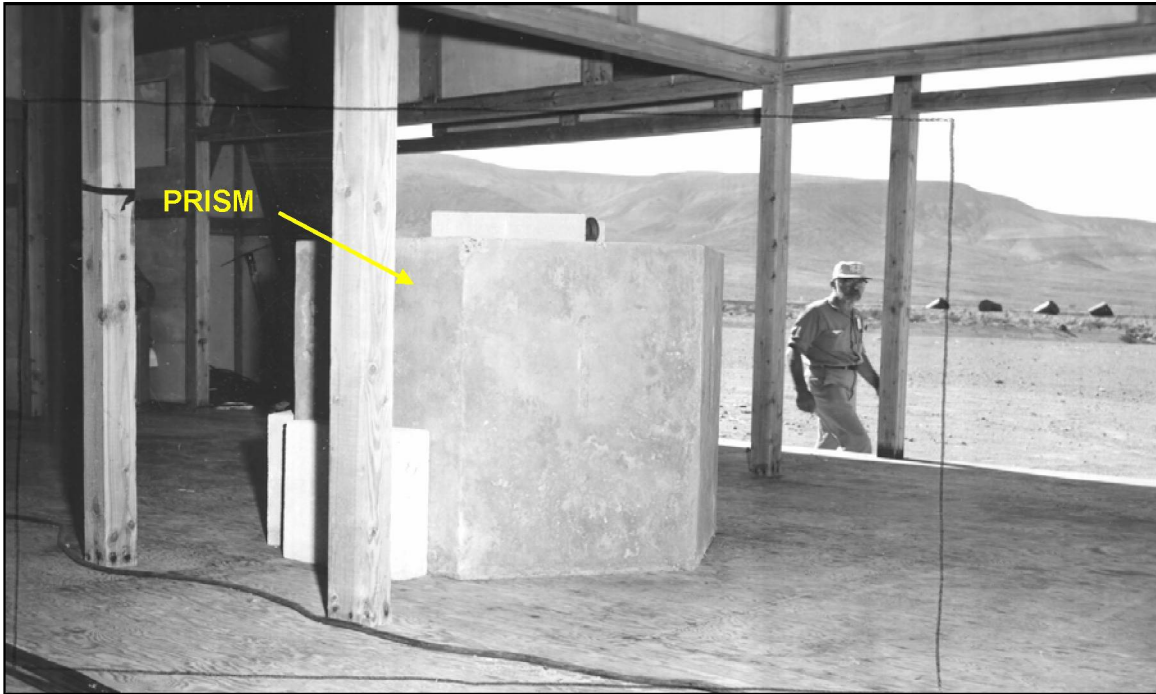

Photo 45. One of the two concrete prisms used in the Operation HENRE Program 1 dosimetry experiments sits inside the analog Japanese House. Collimator row is visible in the background. View is to the southeast. August 3, 1967 (Photo 2515-11 on file at NNSA/NSO Nuclear Testing Archive).



Photo 46. The concrete prism remains in place inside the analog Japanese House. View is to the north-northeast. Photo taken by DRI on November 1, 2006 (on file at NNSA/NSO Curation Facility).

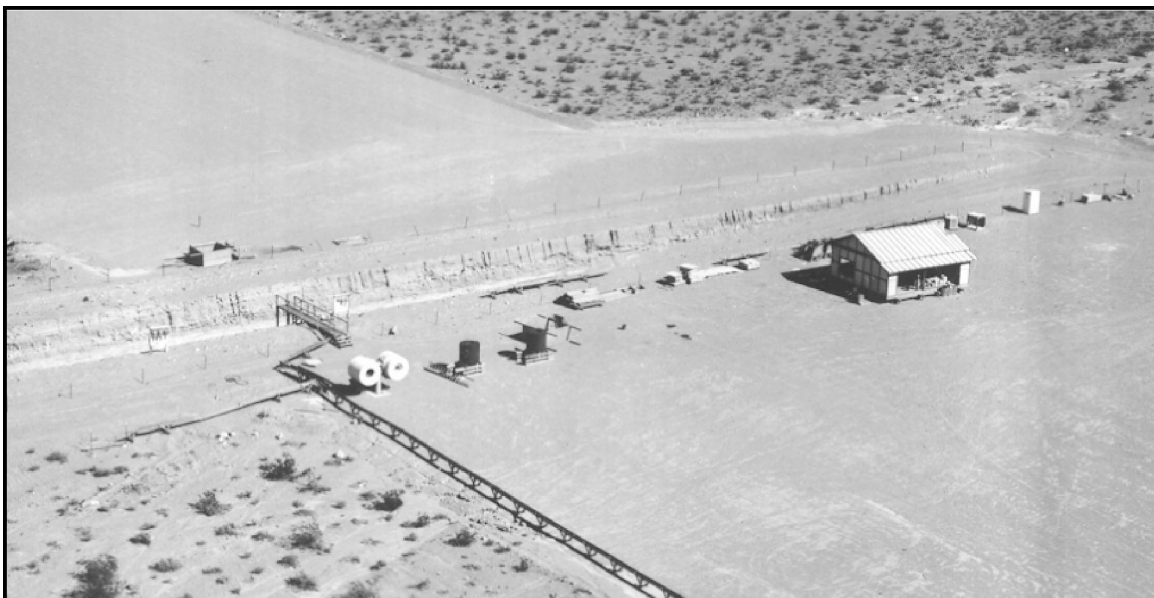

Photo 47. A 1966 overview showing, from left to right, a cable trough and stairs leading to recording trailers in the revetment, a pair of turret-mounted collimators, a pair of platform mounted collimators, stacks of extra transite panels, pipe and supplies, the analog Japanese House, and a porta potty. The crates of authentic Japanese building materials are partially visible behind the Japanese House as is one of the concrete prisms. The trailer revetment, surrounded by a T-post fence extends across the photo behind the house. The cable trough and stairs have been removed and the paired collimator was replaced by an instrument tower for later (post-1970) experimental programs. View is to the northeast (Photo 2581-14 on file at NNSA/NSO Nuclear Testing Archive).



Photo 48. The revetment behind (north) the analog Japanese House held recording trailers for some of the Operation HENRE experimental programs. A metal T-post and rope fence surrounded the revetment. View is to the west. Photo taken September 28, 1966 (Photo 2307-9 on file at NNSA/NSO Nuclear Testing Archive).



Photo 49. Detail of crate containing ceramic roof tiles used in traditional Japanese construction. The tiles were used for the Operation HENRE dosimetry studies conducted on authentic Japanese building materials. The crate is one of several located near the analog Japanese House. Photo taken by DRI on November 1, 2006 (on file at NNSA/NSO Curation Facility).



Photo 50. A crate containing seaweed and crushed oyster shell used for the Operation HENRE dosimetry studies conducted on traditional Japanese building materials. Photo taken by DRI on November 1, 2006 (on file at NNSA/NSO Curation Facility).



Photo 51. A stack of triangular tower sections located immediately west of the analog Japanese House. View is to the northeast. Photo taken by DRI on November 1, 2006 (on file at NNSA/NSO Curation Facility).



Photo 52. A circular depression located 1,580 ft from the base of BREN Tower. View is to the east-southeast. Photo taken by DRI on November 1, 2006 (on file at NNSA/NSO Curation Facility).

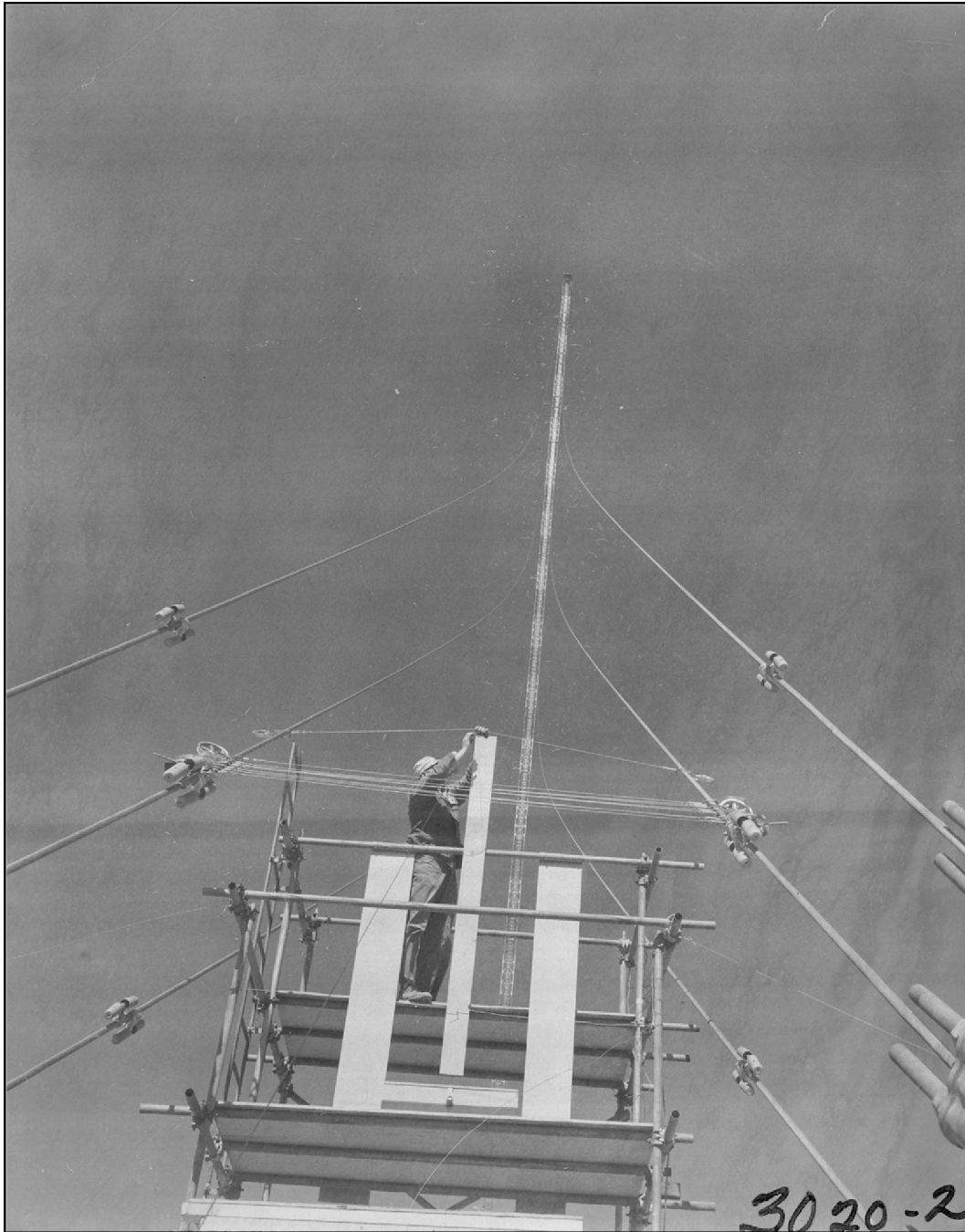

Photo 53. The experimental setup for Operation HENRE, Program 3 included a trolley system attached to the BREN Tower guy wires that allowed instruments to be suspended at different heights. A technician on temporary scaffolding is adjusting the pulley used to raise the instrument phantom platform in this 1966 photo (Photo 3020-2 on file at NNSA/NSO Nuclear Testing Archive).

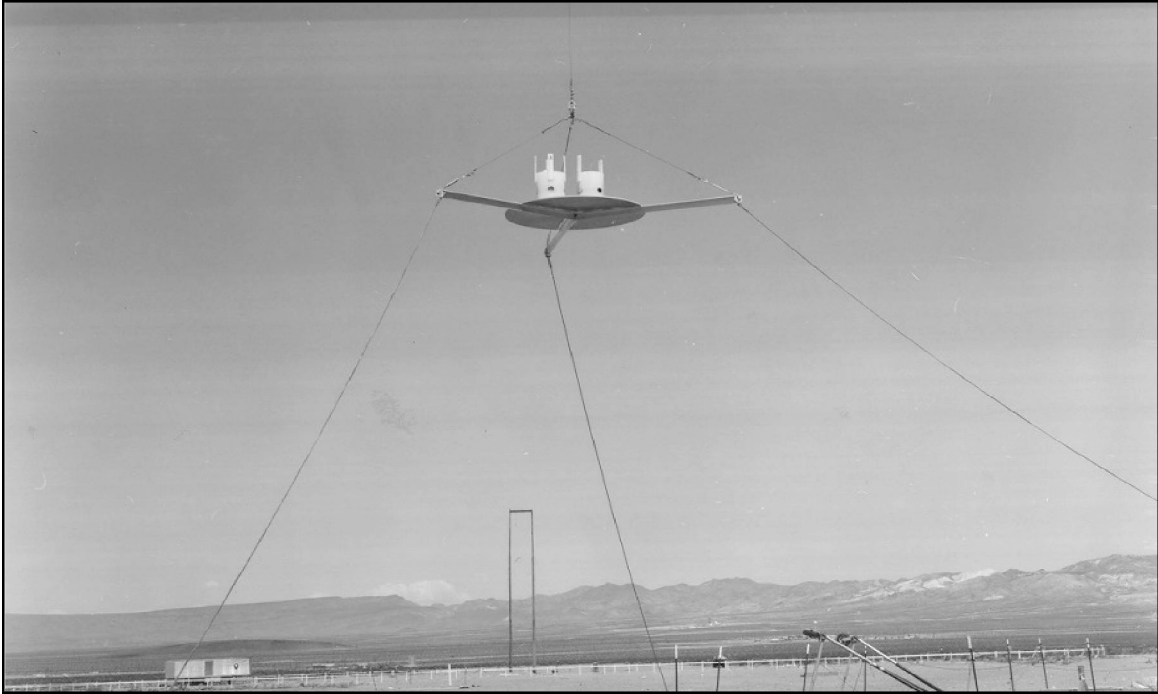

Photo 54. Photo taken May 22, 1967. Instruments for one of the Operation HENRE Program 3 experiments being lifted via a trolley system attached to the BREN Tower's guy wires. The lift system was dismantled at the conclusion of the experiments. View is to the northwest (Photo 2472-5 on file at NNSA/NSO Nuclear Testing Archive).



Photo 55. The aluminum instrument phantom platform seen in Photo 54. It is located about 150 ft southeast of the underground civil defense shelter. View is to the north. Photo taken by DRI on June 2004 (on file at NNSA/NSO Curation Facility).



Photo 56. The BREN Tower (center of frame) dwarfs the three 150 ft towers used for Operation HENRE Program 3. During the neutron accelerator runs, instruments were suspended from cables strung between the towers 120 ft above the ground. Photo taken from the paved access road on July 1, 1966. View is to the southwest (Photo 2268-6 on file at NNSA/NSO Nuclear Testing Archive).

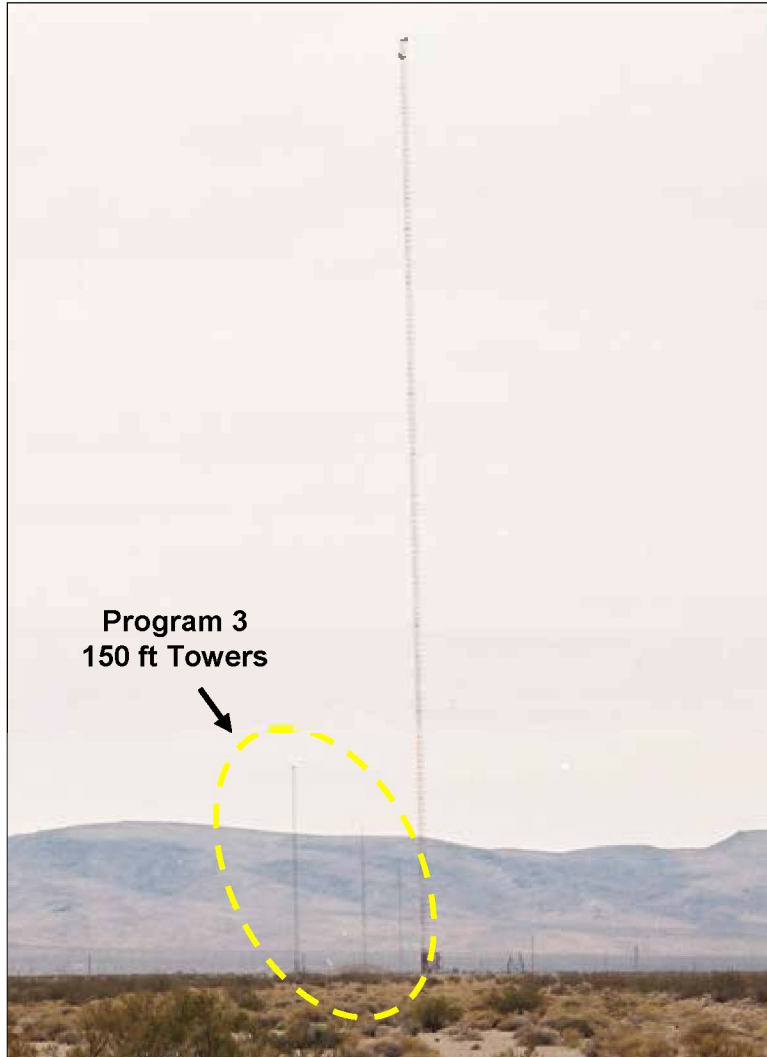

Photo 57. This November 1, 2006 photo taken by DRI shows the BREN Tower looming over the three smaller 150 ft towers used during the Operation HENRE Program 3 experiments. View is to the southwest (on file at NNSA/NSO Curation Facility).



Photo 58. Tower 3.2 used in Operation HENRE Program 3. The pulley and cable system used to suspend the instrumentation for the experiments is visible at the top of the 150 ft tower. View is to the northeast. Photo taken by DRI on November 1, 2006 (on file at NNSA/NSO Curation Facility).

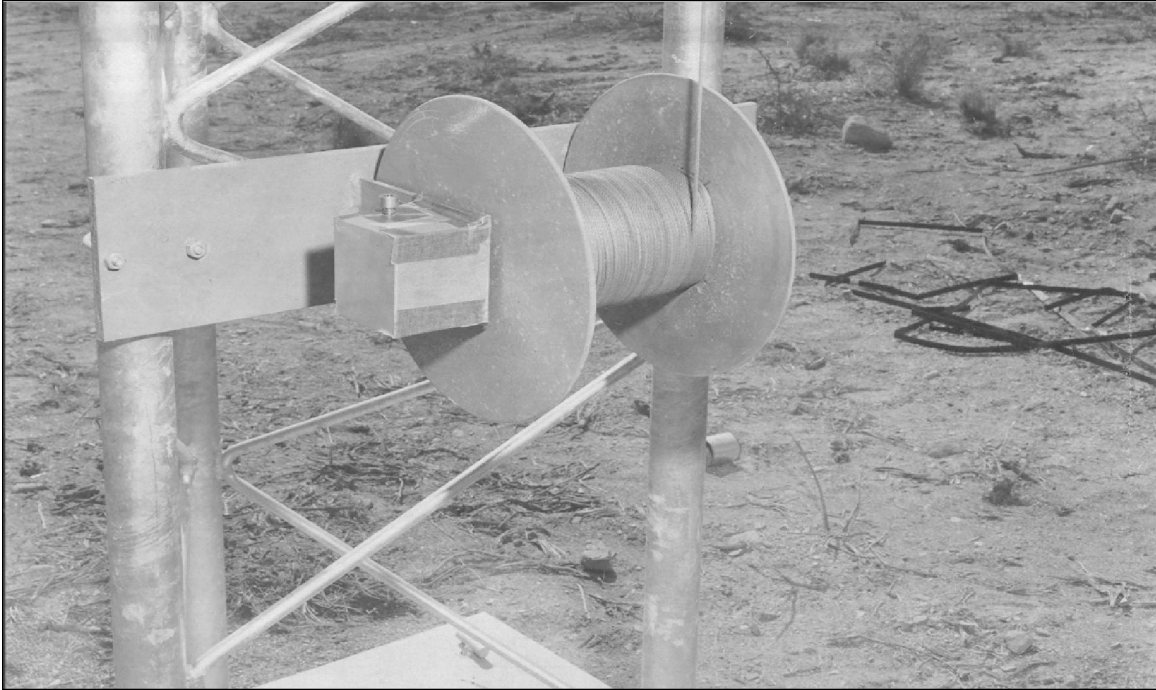

Photo 59. Detail of the hand-cranked winch on the base of one of the 150 ft towers used for some of the Operation HENRE Program 3 experiments in August 1966 (Photo 3029-16 on file at NNSA/NSO Nuclear Testing Archive).



Photo 60. The hand-cranked winch on the base of Tower 3.2. The placard identifies the tower as part of the NDRL Operation HENRE Experimental Program 3 and provides contact phone numbers. View is to the southeast. Photo taken by DRI in June 2004 (on file at NNSA/NSO Curation Facility).



Photo 61. The 88 ft tower used by NRDL during Operation HENRE Program 3. View is to the southeast. Photo taken by DRI on November 1, 2006 (on file at NNSA/NSO Curation Facility).



Photo 62. Overview of the rectangular foxholes with plywood covers built for Operation HENRE, Program 3 in 1966. A metal T-post and rope fence surrounds the area. View is to the north (Photo 3020-6 on file at NNSA/NSO Nuclear Testing Archive).

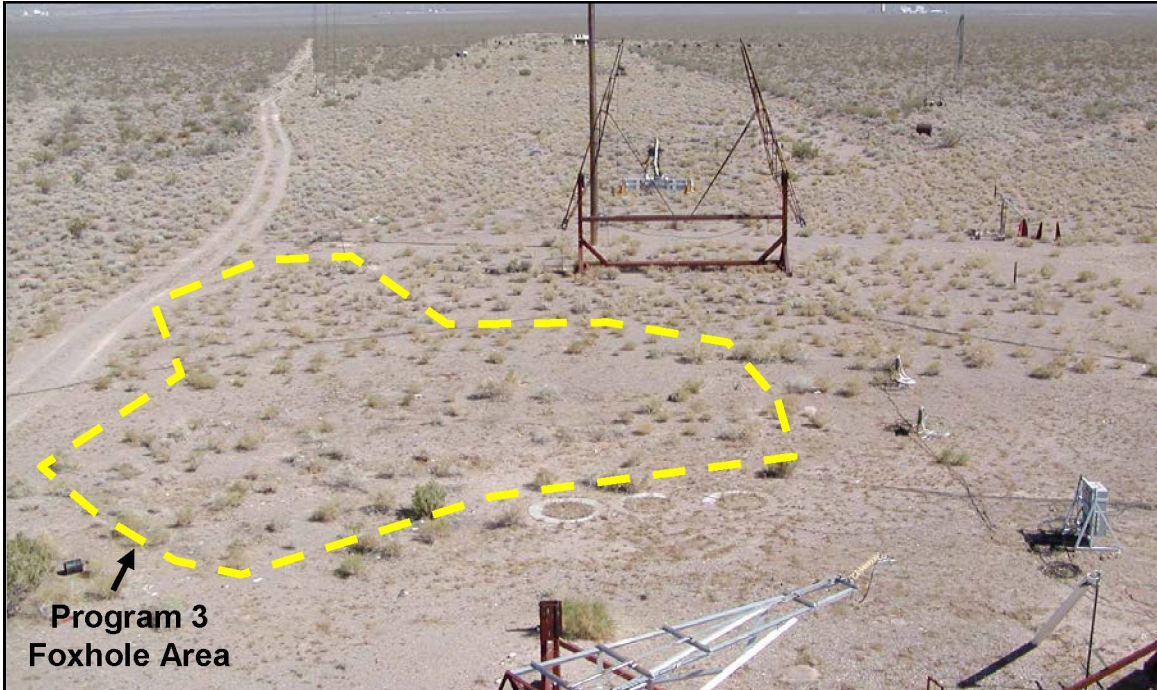

Photo 63. Area where the rectangular foxholes for Operation HENRE Program 3 were built. Area has been filled in. Three of the cylindrical foxholes for Program 5 are visible in the center of the photo below the dotted line. View is to the north. Photo taken by DRI in June 2004 (on file at NNSA/NSO Curation Facility).



Photo 64. October 12, 1966 photograph showing the base and working platform of BREN Tower and the Operation HENRE Program 5 array of cylindrical foxholes. View is to the southwest (Photo 2327-9 on file at NNSA/NSO of Nuclear Testing Archive).



Photo 65. An arc of three cylindrical foxholes used in Operation HENRE Program 5 appear in this photo taken on July 10, 1967 from the main work platform on the BREN Tower. All three have their concrete covers in place as a safety precaution (Photo 2491-3 on file at NNSA/NSO Nuclear Testing Archive).



Photo 66. This is the same arc of three cylindrical foxholes shown in Photo 65. The covers have been removed and all have been filled in. Only the concrete collars are visible. View is to the east. Photo taken by DRI on November 1, 2006 (on file at NNSA/NSO Curation Facility).



Photo 67. The Program 5 cylindrical foxhole located at the base of BREN Tower is almost completely covered with earth. Only a portion of the concrete cover is visible. View is to the west. Photo taken by DRI on November 1, 2006 (on file at NNSA/NSO Curation Facility).



Photo 68. Some of the cylindrical concrete foxhole covers used in Operation HENRE Program 5. The stack is located immediately west of BREN Tower. View is to the west. Photo taken by DRI on November 1, 2006 (on file at NNSA/NSO Curation Facility).



Photo 69. One of the T-post enclosures for the Operation HENRE Program 6 instrument stations. View is towards the northwest. Photo taken August 18, 1967 (Photo 2532-1 on file at NNSA/NSO Nuclear Testing Archive).

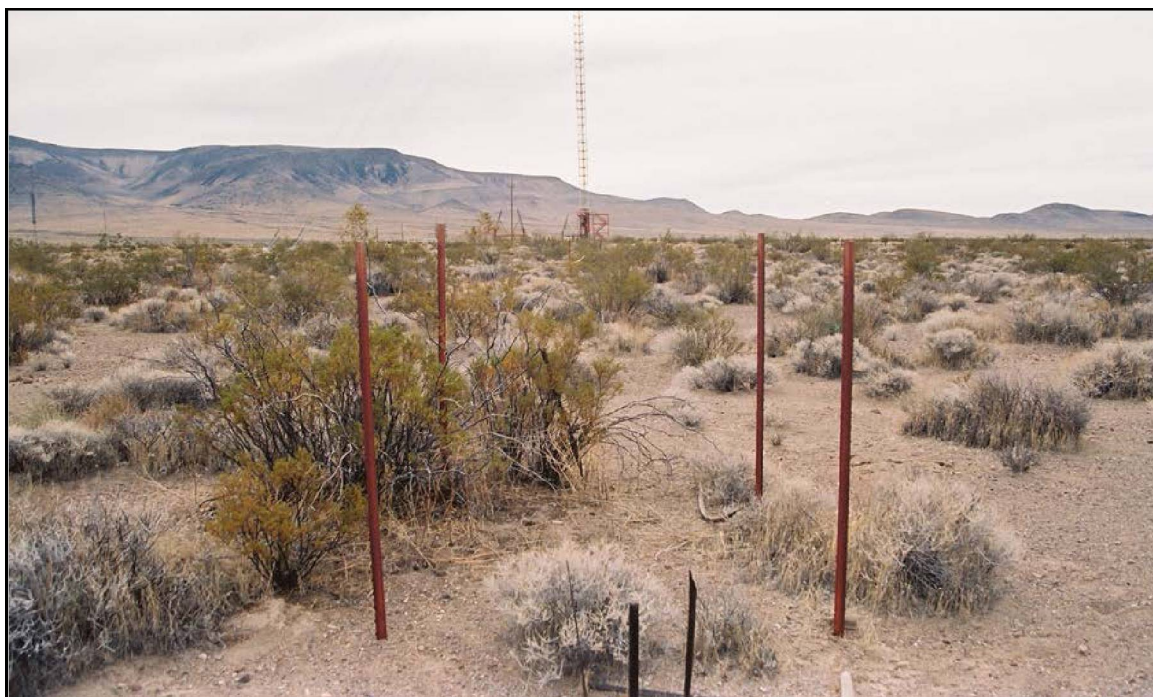

Photo 70. One of the T-post enclosures for the Operation HENRE Program 6 instrument stations. View is to the south. Photo taken by DRI on November 1, 2006 (on file at NNSA/NSO Curation Facility).



Photo 71. The concrete turntable used for Operation HENRE Program 9 involving shielding studies for the radiological armored pod or RAP. View is to the north. Photo taken by DRI on November 1, 2006 (on file at NNSA/NSO Curation Facility).



Photo 72. Program 9 equipment and instrumentation were mounted to the turntable stand shown here and rotated into various positions relative to the neutron accelerator mounted on BREN Tower. View to the southeast. Photo taken by DRI on November 1, 2006 (on file at NNSA/NSO Curation Facility).



Photo 73. Detail of the Program 9 turntable and the degree markings painted on the rotating platform. Photo taken by DRI on November 1, 2006 (on file at NNSA/NSO Curation Facility).

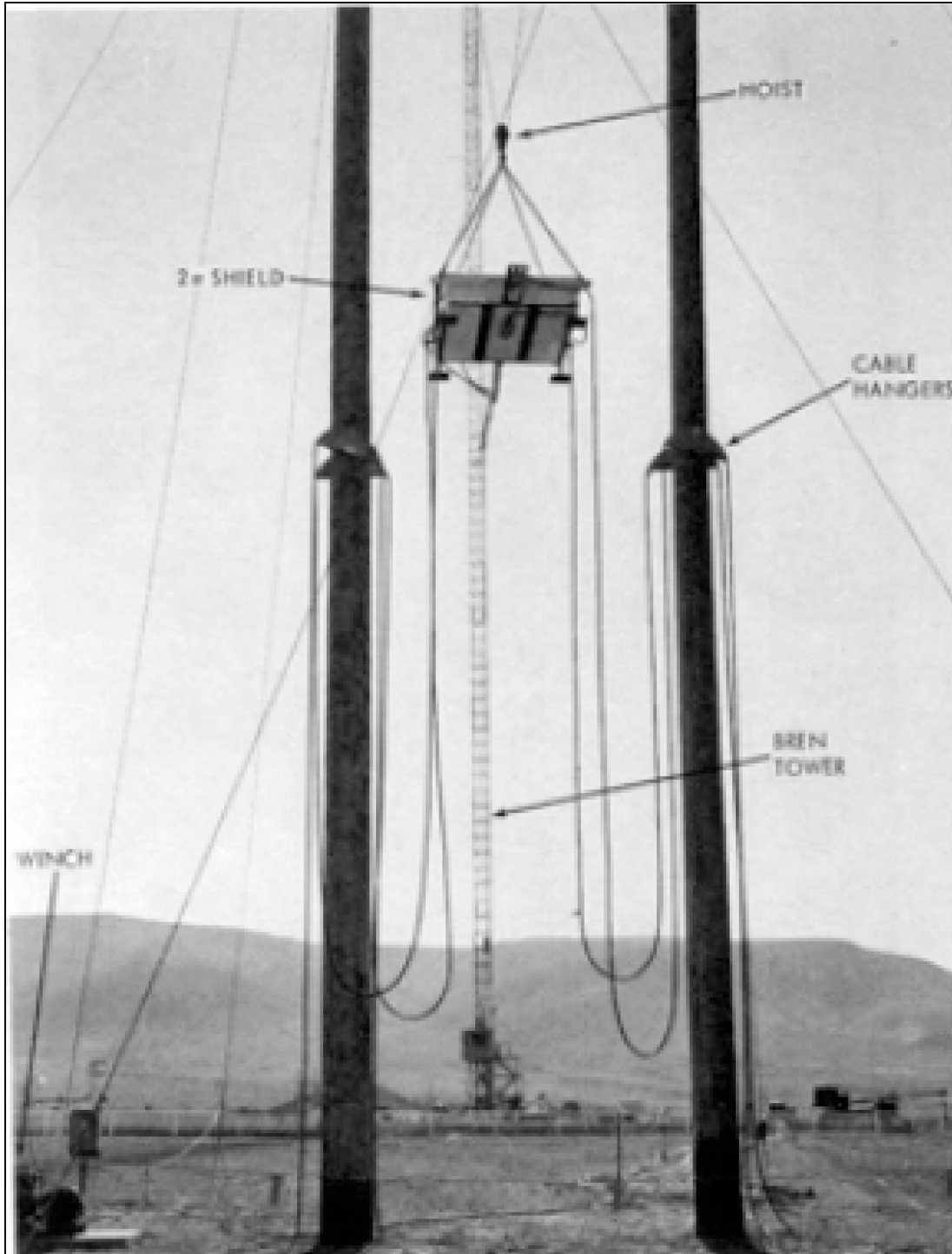

Photo 74. Experimental setup for Program 9, Project 9.2, showing the polyethylene slab and detectors suspended between the wooden towers. The winch system is visible to the left and the fencing surrounding the trailer revetment is visible in the background. The view is south-southeast toward BREN Tower (Photo from French and Mooney 1971).



Photo 75. The wooden tower used for the Operation HENRE Program 9 battle tank shielding studies. View is to the north-northeast. Photo taken by DRI on November 1, 2006 (on file at NNSA/NSO Curation Facility).



Photo 76. The winch sits adjacent to the wooden tower. It was used to hoist the polyethylene shield and detectors into position for the Program 9 experiments. View is to the north. Photo taken by DRI on November 1, 2006 (on file at NNSA/NSO Curation Facility).



Photo 77. The covered trailer revetment located 750 ft from the base of BREN Tower was used to shelter the recording trailers for Operation HENRE experimental Programs 2 and 9. The wood and metal cover has collapsed. View is to the northeast. Photo taken by DRI on November 01, 2006 (on file at NNSA/NSO Curation Facility).



Photo 78. The gated entrance to the BREN Tower Complex in Area 25, September 28, 1966. Cane Spring Road runs across the photo. View is to the southeast (Photo 2307-16 on file at NNSA/NSO Nuclear Testing Archive).



Photo 79. The complex's gated entrance in June 2004. The original gate was replaced sometime after the conclusion of Operation HENRE. View is to the southeast (on file at NNSA/NSO Curation Facility).



Photo 80. The remote trailer park in September 1966 during Operation HENRE with support trailers from the various research groups participating in the experimental programs. View is to the northeast (Photo 2307-11 on file at NNSA/NSO Nuclear Testing Archive).



Photo 81. The support trailers, water tank, and portable generators have been removed from the remote trailer park. Only the substation south of the trailer park remains. View is to the northeast. Photo taken by DRI on November 1, 2006 (on file at NNSA/NSO Curation Facility).



Photo 82. Substation 28-2 which serviced the remote support trailer park and heliport for Operation HENRE. The edge of the graded area for the trailer park is at the left edge of the photo. The heliport was about 250 ft south of the substation. View is to the east. Photo taken by DRI on November 1, 2006 (on file at NNSA/NSO Curation Facility).

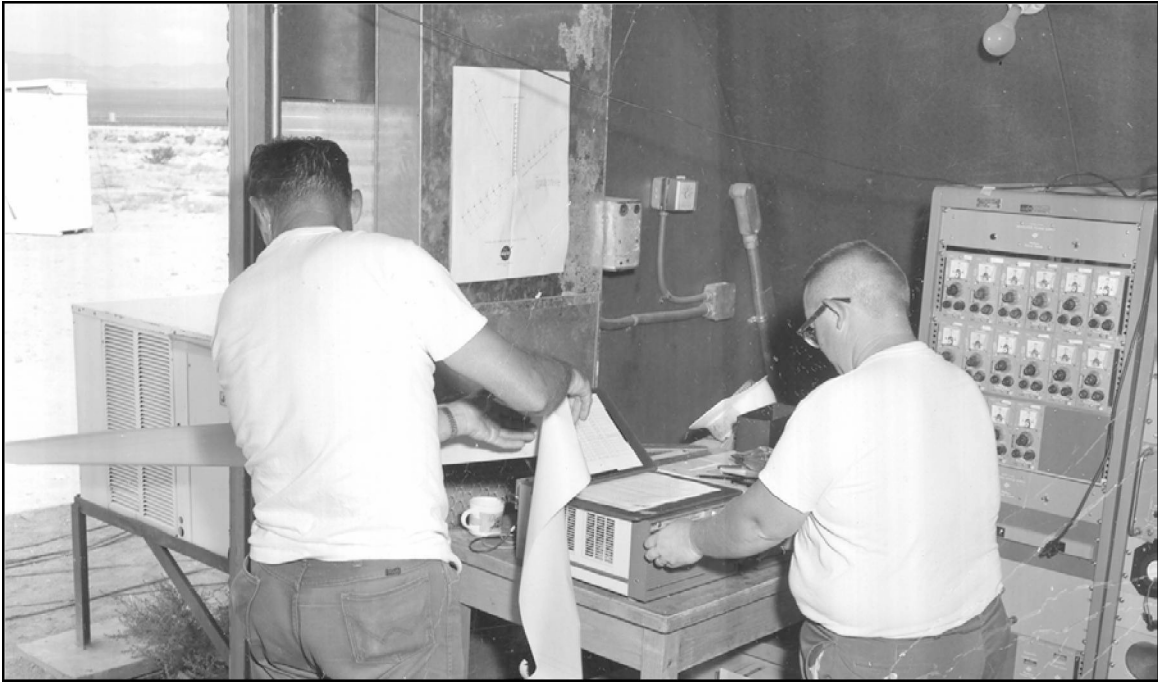

Photo 83. Technicians working on recording instrumentation for the sonic boom experiments conducted at the BREN Tower Complex in NTS Area 25 in 1970. The men are inside the Quonset hut southeast of the tower. Photo taken August 25, 1970 (Photo 3219-7 on file at NNSA/NSO Nuclear Testing Archive).



Photo 84. Technician adjusting field instrumentation for the sonic boom experiments. BREN Tower and the double wooden tower from Operation HENRE Program 9 are visible in the distance behind the technician. Photo taken August 25, 1970 (Photo 3219-11 on file at NNSA/NSO Nuclear Testing Archive).



Photo 85. Technician rigging BREN Tower with instrumentation for the sonic boom tests. Photo taken August 26, 1970 (Photo 3221-16 on file at NNSA/NSO Nuclear Testing Archive).



Photo 86. NASA Sonic Boom Test personnel standing southeast of the BREN Tower, August 26 1970. Winch from Operation HENRE is to the right, but the brockhouse and walkway seen in Photo 17 have been dismantled (Photo 3221-1 on file at NNSA/NSO Nuclear Testing Archive).